

DRUM DOLLY - DRUM-DP-HD-55-BK

APPROX WEIGHT: 36.42 lbs.
DOES NOT INCLUDE WEIGHT OF POWER OR PACKAGING!!!

*** ANY ADDITIONS, DELETIONS, OR OMISSIONS MUST BE CORRECTED ON THIS DRAWING AS THIS DRAWING WILL BE CONSIDERED ALL INCLUSIVE ***

ALL GRAPHICS PROVIDED ARE FOR REFERENCE ONLY. IF CERTAIN DIMENSIONS ARE CRITICAL PLEASE VERIFY THOSE DIMENSIONS WITH YOUR SALESPERSON

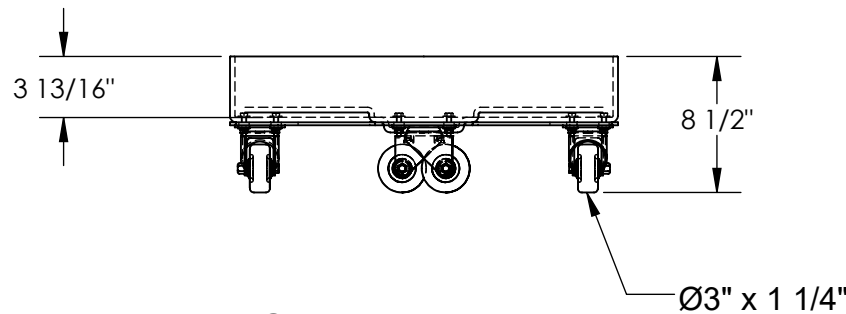
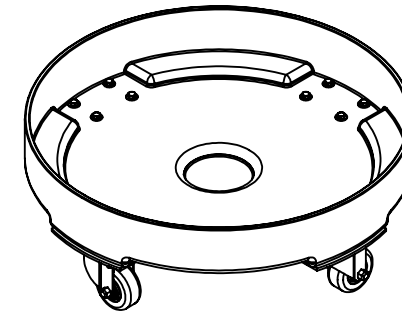
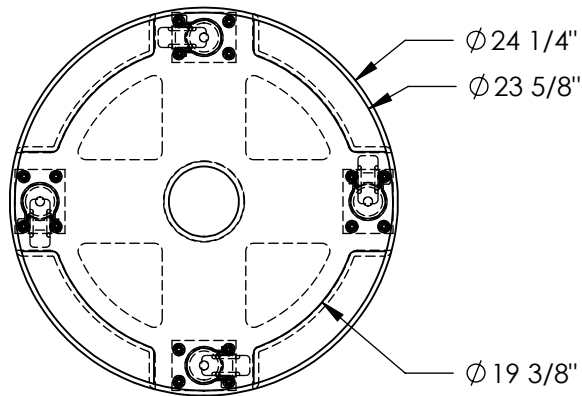

DIMENSION TOLERANCE $\pm 1/2"$

STANDARD FEATURES

- MODEL NUMBER IS DRUM-DP-HD-55-BK
- OVERALL DIAMETER IS $\phi 24 \frac{1}{4}"$
- INNER DIAMETER IS $\phi 23 \frac{5}{8}"$
- OVERALL HEIGHT IS $8 \frac{1}{2}"$
- MAX CAPACITY IS 600 LBS
- MADE FROM HIGH DENSITY POLYETHYLENE
- HARD RUBBER CASTERS: $\phi 3" \times 1 \frac{1}{4}"$
- STEEL SUPPORT BASE: TOUGH BAKED IN POWDERCOATED YELLOW FINISH
- BLACK POLYETHYLENE
- WORKS WITH 55 OR 30 GALLON DRUMS

SPECIAL FEATURES

NONE

APPROVAL	I, THE UNDERSIGNED, AGREE THAT THE PRODUCT AS REPRESENTED SATISFIES DESIGN AND DIMENSION REQUIREMENTS. I ALSO ACKNOWLEDGE MY DUTY TO CONFIRM PRODUCT AND INSTALLATION COMPLIANCE WITH ALL APPLICABLE FEDERAL, STATE AND LOCAL REGULATIONS AND STANDARDS.	
	UNITS REQUIRING APPROVAL DRAWINGS OR MODIFIED ARE NON-RETURNABLE	
	[] As drawn [] As marked	
Signed: _____		Date: _____
Printed Name: _____		
<i>LEAD TIME WILL START UPON RECEIPT OF SIGNED APPROVAL DRAWING</i>		

DISTRIBUTOR'S NAME:		P.O.#
VESTIL MANUFACTURING		X
		W.O.#
DRAWN BY: KGH		X
DATE: 6/15/2017		SALES: X
REFERENCE: X	SCALE: 1:12	FILE NAME:
QUOTED LEAD TIME: X	QUOTE # X	31-007-280