

PREMIUM TRUCK SCISSOR DOCK LIFT - WL-100-5-68

ANY ADDITIONS, DELETIONS, OR OMISSIONS MUST BE CORRECTED ON THIS DRAWING AS THIS DRAWING WILL BE CONSIDERED ALL INCLUSIVE
 ALL GRAPHICS PROVIDED ARE FOR REFERENCE ONLY. IF CERTAIN DIMENSIONS ARE CRITICAL PLEASE VERIFY THOSE DIMENSIONS WITH YOUR SALESPERSON

STANDARD FEATURES

MODEL NUMBER: WL-100-5-68
 UNIT TO BE MOUNTED: AT SURFACE OR IN PIT (CIRCLE ONE)
 CAPACITY (EVENLY DISTRIBUTED): 5,000 LBS
 OVERALL PLATFORM SIZE: (72" X 96")
 RAISED HEIGHT 68" ± 2"
 LOWERED HEIGHT: 8"
 REMOVABLE HANDRAILS AND 4"NON-REMOVABLE TOE BOARDS 45" HT W/ 21" MID-RAIL
 USABLE WIDTH: 64 5/8"
 TRUCK BRIDGE IS 72" W X 18" L AT ROLLER END W/ CHAINS & HANDLES
 FRAME SIZE IS: 62" W X 93" L
 SHIPPING WT APPROX: 3200 LBS ±
 6 1/2 HP EXTERNAL POWER UNIT (SEE BOTTOM OF PAGE)

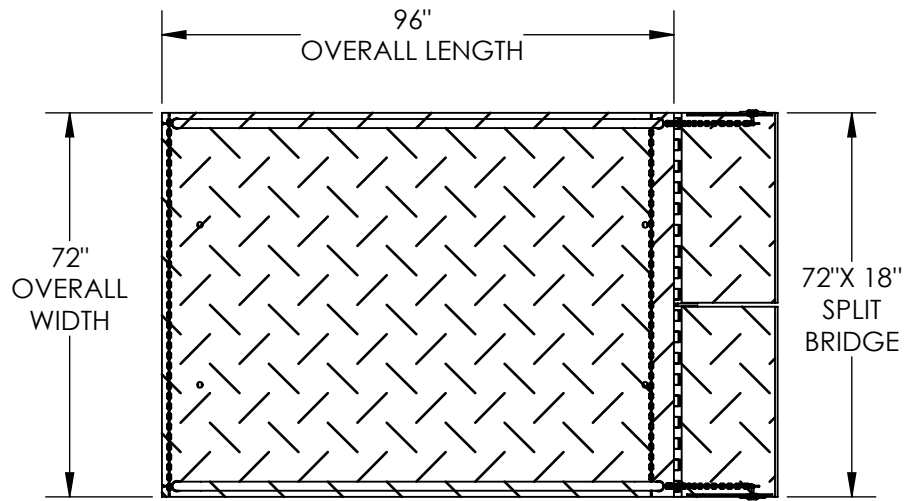

** STANDARD UNIT NOT INTENDED FOR SIDE CROSS LOAD **

W/ 8' OF HYDRAULIC HOSE
 -CONTROL IS HANDHELD, 2 BUTTON, NEMA 4 PENDANT WITH 4'-20' USABLE COIL CORD
 REFER TO THE UNIT'S ELECTRICAL DIAGRAM FOR ELECTRICAL SERVICE REQUIREMENTS
 -INSTALL TO MEET ALL APPLICABLE STATE & LOCAL CODES FOR YOUR AREA!
 5" BEVELED TOE GUARD
 ARCHITECTURAL REVIEW FOR CORRECTNESS OF PIT AND FOR COMPLIANCE TO LOCAL AND STATE CODES IS RECOMMENDED.

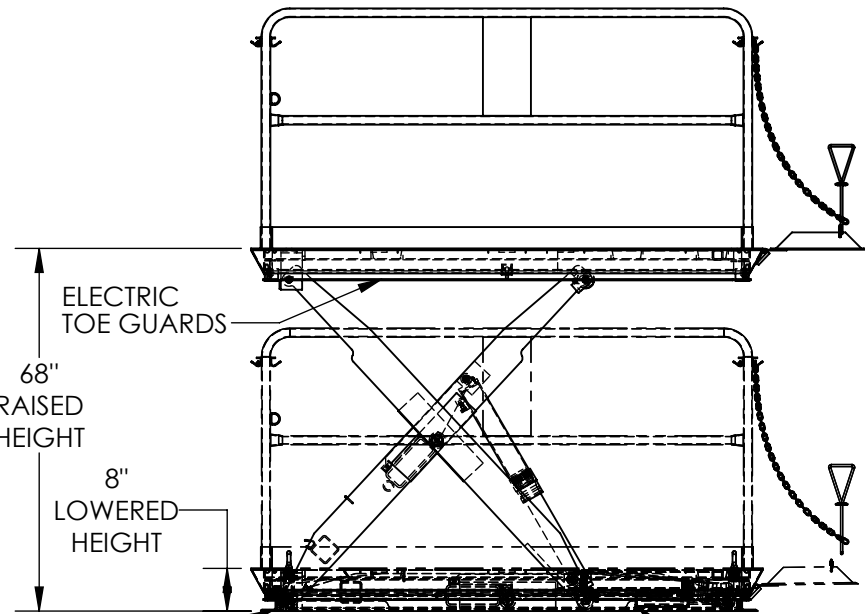

UNIT IS DURABLE LIQUID PAINT BROWN FINISH
 HANDRAILS ARE TOUGH BAKED IN POWDER COATED YELLOW FINISH
 DIMENSION TOLERANCE ± 1/4"

SPECIAL FEATURES

NONE

HOSE & CORD EXIT FRAME THIS END

SAFETY MAINTENANCE PROPS

HYDRAULIC UNIT OVERALL DIMENSIONS 14"W x 33"L x 31"H (COMES W/ 8FT HOSE)

APPROVAL

I, THE UNDERSIGNED, AGREE THAT THE PRODUCT AS REPRESENTED SATISFIES DESIGN AND DIMENSION REQUIREMENTS. I ALSO ACKNOWLEDGE MY DUTY TO CONFIRM PRODUCT AND INSTALLATION COMPLIANCE WITH ALL APPLICABLE FEDERAL, STATE AND LOCAL REGULATIONS AND STANDARDS.
UNITS REQUIRING APPROVAL DRAWINGS OR MODIFIED ARE NON-RETURNABLE
 As drawn As marked

Signed: _____ Date: _____

Printed Name: _____

LEAD TIME WILL START UPON RECEIPT OF SIGNED APPROVAL DRAWING

POWER	AC	DC (12V)	AIR/OIL
MOTOR VOLTAGE	115	208	230 460
DEDICATED CIRCUIT REQUIRED 60HZ			
MOTOR PHASE	SINGLE	THREE	
CONTROL	HAND	FOOT	



DISTRIBUTOR'S NAME:		P.O.#
VESTIL MANUFACTURING		X
DRAWN BY: DLS		W.O.#
DATE: 5/1/2015		X
REFERENCE: X	SCALE: 1:36	SALES: X
QUOTED LEAD TIME: X	QUOTE #	FILE NAME:
	X	05-007-301