

# PREMIUM TRUCK SCISSOR DOCK LIFT - WL-100-6-68

\*\*\*ANY ADDITIONS, DELETIONS, OR OMISSIONS MUST BE CORRECTED ON THIS DRAWING AS THIS DRAWING WILL BE CONSIDERED ALL INCLUSIVE\*\*\*  
 ALL GRAPHICS PROVIDED ARE FOR REFERENCE ONLY. IF CERTAIN DIMENSIONS ARE CRITICAL PLEASE VERIFY THOSE DIMENSIONS WITH YOUR SALESPERSON

## STANDARD FEATURES

MODEL NUMBER: WL-100-6-68  
 UNIT TO BE MOUNTED: AT SURFACE OR IN PIT (CIRCLE ONE)  
 CAPACITY (EVENLY DISTRIBUTED): 6,000 LBS  
 OVERALL PLATFORM SIZE: (72" X 96")  
 RAISED HEIGHT 70" ± 2"  
 LOWERED HEIGHT: 10"  
 REMOVABLE HANDRAILS AND 4"NON-REMOVABLE TOE BOARDS 42" HT W/ 21" MIDRAIL  
 USABLE WIDTH: 64 5/8"  
 TRUCK BRIDGE IS 72" W X 18" L AT ROLLER END W/ CHAINS & HANDLES  
 FRAME SIZE IS: 62" W X 93" L  
 SHIPPING WT APPROX: 3300 LBS ±  
 6 1/2 HP POWER UNIT (SEE BOTTOM OF PAGE)

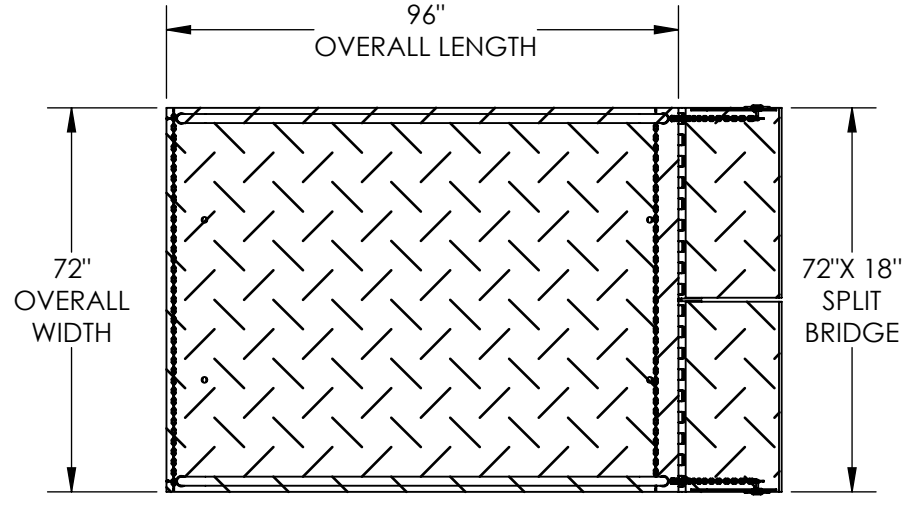

\*\* STANDARD UNIT NOT INTENDED FOR SIDE CROSS LOAD \*\*

W/ 8' OF HYDRAULIC HOSE  
 -HAND-HELD CONTROL ON A 4'-20' COIL CORD  
 REFER TO THE UNIT'S ELECTRICAL DIAGRAM FOR ELECTRICAL SERVICE REQUIREMENTS  
 -INSTALL TO MEET ALL APPLICABLE STATE & LOCAL CODES FOR YOUR AREA!  
 5" BEVELED TOE GUARD  
 ARCHITECTURAL REVIEW FOR CORRECTNESS OF PIT AND FOR COMPLIANCE TO LOCAL AND STATE CODES IS RECOMMENDED.

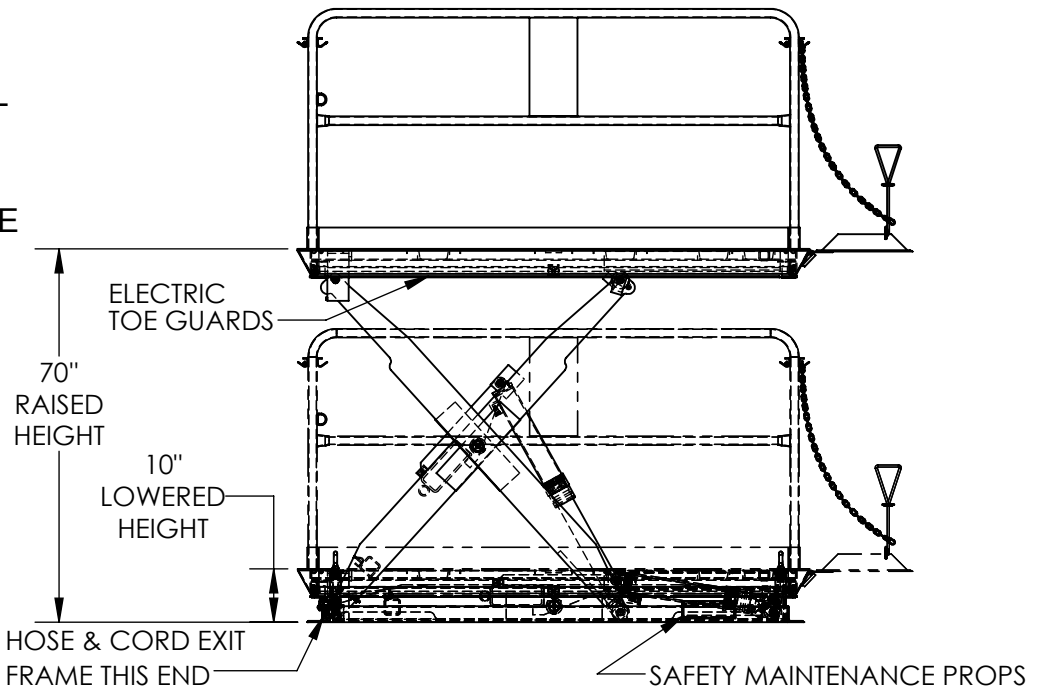

UNIT IS DURABLE LIQUID PAINT BROWN FINISH  
 HANDRAILS ARE TOUGH BAKED IN POWDER COATED YELLOW FINISH

DIMENSION TOLERANCE ± 1/4"

## SPECIAL FEATURES

NONE

HYDRAULIC UNIT OVERALL DIMENSIONS 14"W x 33"L x 31"H (COMES W/ 8FT HOSE)

**A P P R O V A L**

I, THE UNDERSIGNED, AGREE THAT THE PRODUCT AS REPRESENTED SATISFIES DESIGN AND DIMENSION REQUIREMENTS. I ALSO ACKNOWLEDGE MY DUTY TO CONFIRM PRODUCT AND INSTALLATION COMPLIANCE WITH ALL APPLICABLE FEDERAL, STATE AND LOCAL REGULATIONS AND STANDARDS.  
**UNITS REQUIRING APPROVAL DRAWINGS OR MODIFIED ARE NON-RETURNABLE**  
 As drawn       As marked

Signed: \_\_\_\_\_ Date: \_\_\_\_\_  
 Printed Name: \_\_\_\_\_

**LEAD TIME WILL START UPON RECEIPT OF SIGNED APPROVAL DRAWING**

POWER	AC	<del>DC (12V)</del>	<del>AIR/OIL</del>
MOTOR VOLTAGE	<del>115</del>	<del>208</del>	<del>230</del> 460
DEDICATED CIRCUIT REQUIRED 60HZ			
MOTOR PHASE	<del>SINGLE</del>	THREE	
CONTROL	HAND	<del>FOOT</del>	

DISTRIBUTOR'S NAME:		P.O.#
VESTIL MANUFACTURING		X
W.O.#	SALES:	FILE NAME:
X	X	05-007-307
DRAWN BY: DLS	DATE: 5/1/2015	SCALE: 1:36
REFERENCE: X	QUOTE # X	
QUOTED LEAD TIME: X		

