

STATIONARY LEGS REPLACEMENT - AHA-STLO

APPROX WEIGHT: 26.56 lbs.
 DOES NOT INCLUDE WEIGHT OF POWER OR PACKAGING!!!

*** ANY ADDITIONS, DELETIONS, OR OMISSIONS MUST BE CORRECTED ON THIS DRAWING AS THIS DRAWING WILL BE CONSIDERED ALL INCLUSIVE ***

ALL GRAPHICS PROVIDED ARE FOR REFERENCE ONLY. IF CERTAIN DIMENSIONS ARE CRITICAL PLEASE VERIFY THOSE DIMENSIONS WITH YOUR SALESPERSON

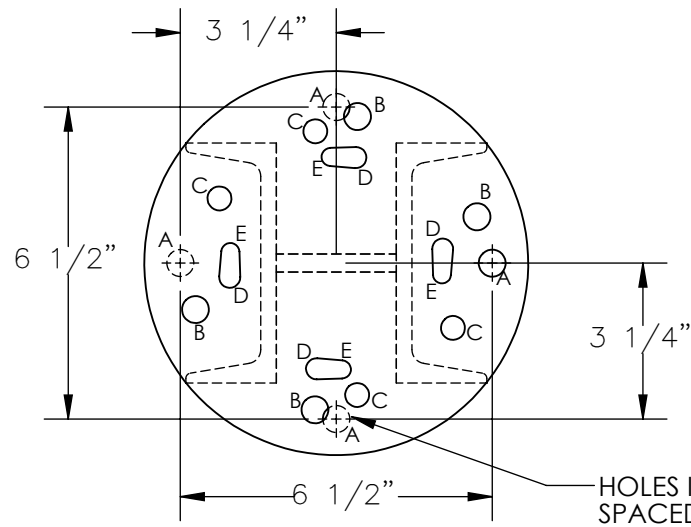

HOLE CHART *

- A = HOLES IN BASE ARE (4) $\phi 9/16$ - (BASE HARDWARE NOT INCLUDED)
- B = HOLES FOR AHS-8/AHA-6 ARE (4) $\phi 9/16$ --- 28-154-049
- C = HOLES FOR AHS-6 ARE (4) $\phi 1/2$ ----- 28-154-050 MOUNTING HARWARE KIT NEEDED
- D = HOLES FOR AHA-2/-4 ARE (4) $\phi 7/16$ ----- 28-154-051 FOR GANTRY MODEL LISTED
- E = HOLES FOR AHS-2/-4 ARE (4) $\phi 3/8$ ----- 28-154-052

* = THE AHA-STLO STATIONARY LEG HAS HOLES FOR ALL MODELS OF GANTRY CRANES, USE THE HOLES LISTED FOR THE MODEL OF CRANE BEING USED.

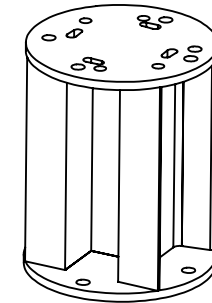

3-D VIEW FOR REFERENCE

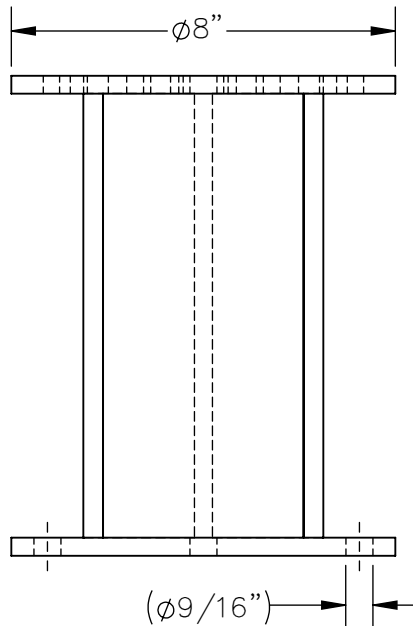
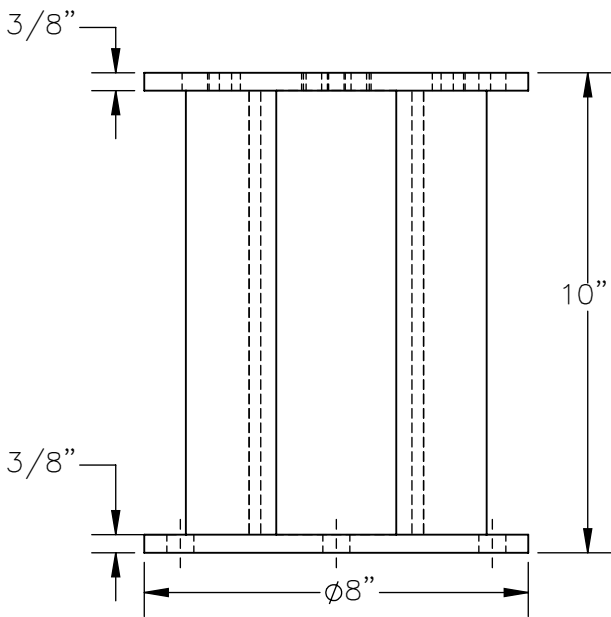

(4) WELDMENTS AND (4) MOUNTING HARDWARE KITS ARE REQUIRED FOR THE BOLT DOWN OPTION FOR A GANTRY CRANE.

DIMENSION TOLERANCE $\pm 1/4$ "

STANDARD FEATURES

- MODEL NUMBER IS AHA-STLO
- OVERALL WIDTH IS 8"
- OVERALL LENGTH IS 8"
- OVERALL HEIGHT IS 10"
- STATIONARY LEGS ARE WELDED
- STEEL CONSTRUCTION

SPECIAL FEATURES

NONE

APPROVAL	I, THE UNDERSIGNED, AGREE THAT THE PRODUCT AS REPRESENTED SATISFIES DESIGN AND DIMENSION REQUIREMENTS. I ALSO ACKNOWLEDGE MY DUTY TO CONFIRM PRODUCT AND INSTALLATION COMPLIANCE WITH ALL APPLICABLE FEDERAL, STATE AND LOCAL REGULATIONS AND STANDARDS.		
	ANY MODIFIED UNITS ARE NON-RETURNABLE		
	[] As drawn		[] As marked
	Signed: _____		Date: _____
Printed Name: _____		LEAD TIME WILL START UPON RECEIPT OF SIGNED APPROVAL DRAWING	

FOR INTERNAL USE ONLY PROJECT SIGN OFF		DISTRIBUTOR'S NAME:		P.O.#
		VESTIL MANUFACTURING		X
SALES		DRAWN BY: MTS	DATE: 03/31/2017	W.O.#
ENG.		REFERENCE: X	SCALE: 1:4	X
FAB.		QUOTED LEAD TIME: X	QUOTE #	FILE NAME:
POWER			X	28-007-415-001