

GAS POWERED ALL TERRAIN PALLET TRUCK - ALL-T-2-GPT

ANY ADDITIONS, DELETIONS, OR OMISSIONS MUST BE CORRECTED ON THIS DRAWING AS THIS DRAWING WILL BE CONSIDERED ALL INCLUSIVE
 APPROX WEIGHT: 953 lbs.
 DOES NOT INCLUDE WEIGHT OF POWER OR PACKAGING!!!

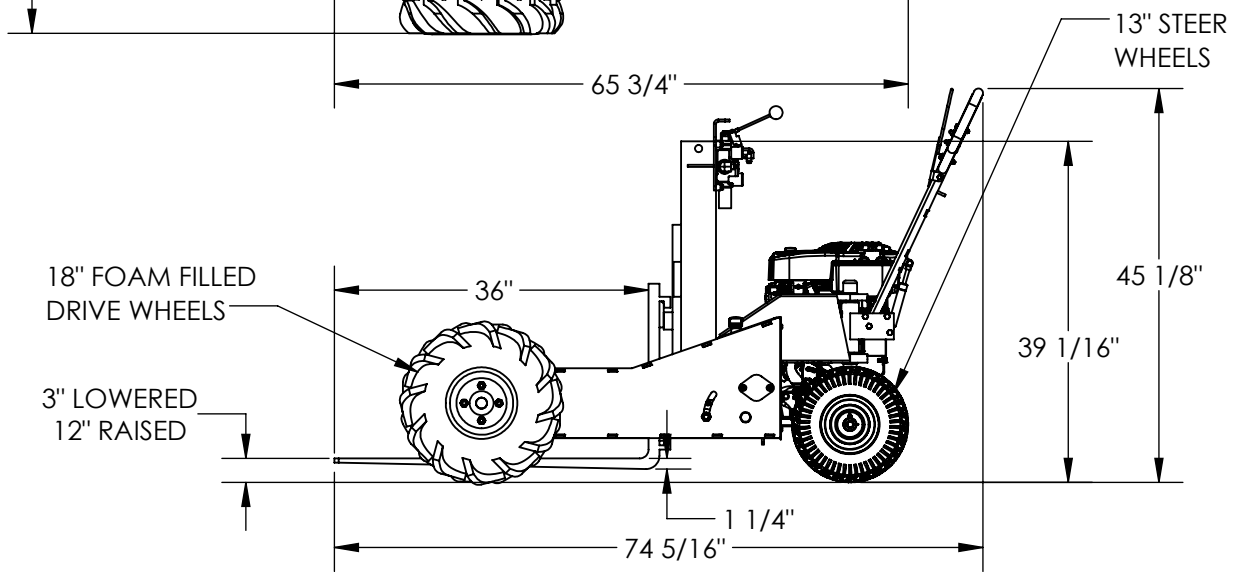
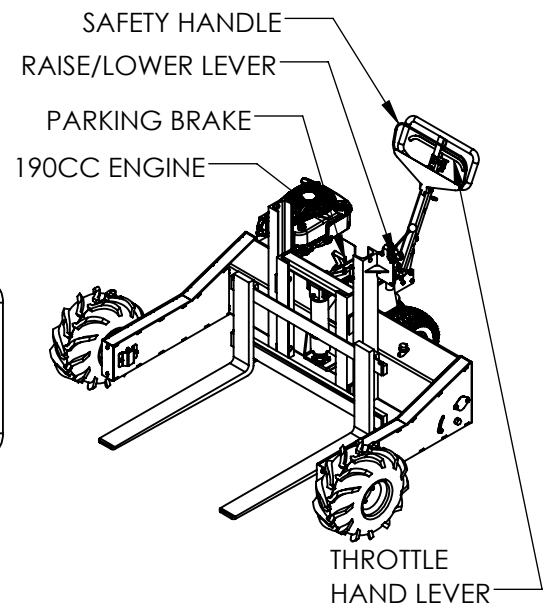
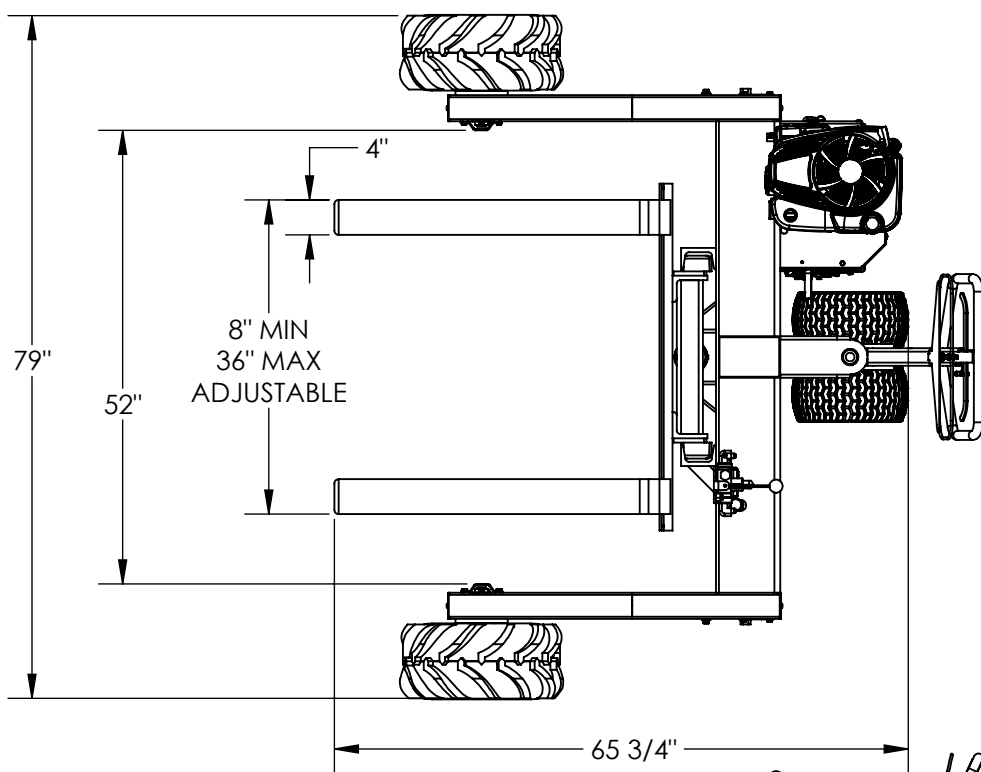

FOR INTERNAL USE ONLY PROJECT SIGN OFF	
SALES	
ENG.	
FAB.	
POWER	

ALL GRAPHICS PROVIDED ARE FOR REFERENCE ONLY. IF CERTAIN DIMENSIONS ARE CRITICAL PLEASE VERIFY THOSE DIMENSIONS WITH YOUR SALESPERSON
 DIMENSION TOLERANCE ± 1"

- STANDARD FEATURES**
 MODEL NUMBER IS ALL-T-2-GPT
 CAPACITY IS 2,000 LBS
 OVERALL WIDTH IS 79"
 STRADDLE WIDTH IS 52"
 SERVICE RANGE IS 3" TO 12"
 FORKS ARE ADJUSTABLE FROM 8" TO 36"
 FORKS ARE 1 1/4" THICK X 4" WIDE X 36" LONG
 OVERALL LENGTH IS 74 5/16"
 OVERALL HEIGHT IS 45 1/8"
 18" FOAM FILLED FRONT WHEELS
 SAFETY HANDLE WITH FORWARD/NEUTRAL/REVERSE
 190CC BRIGGS AND STRATTON ENGINE
 HAND LEVER TO CONTROL LIFT/LOWER
 DURABLE LIQUID PAINT BLUE FINISH

SPECIAL FEATURES
 NONE

A P P R O V A L

I, THE UNDERSIGNED, AGREE THAT THE PRODUCT AS REPRESENTED SATISFIES DESIGN AND DIMENSION REQUIREMENTS. I ALSO ACKNOWLEDGE MY DUTY TO CONFIRM PRODUCT AND INSTALLATION COMPLIANCE WITH ALL APPLICABLE FEDERAL, STATE AND LOCAL REGULATIONS AND STANDARDS.
UNITS REQUIRING APPROVAL DRAWINGS OR MODIFIED ARE NON-RETURNABLE
 As drawn As marked

Signed: _____ Date: _____
 Printed Name: _____
 LEAD TIME WILL START UPON RECEIPT OF SIGNED APPROVAL DRAWING

DISTRIBUTOR'S NAME: VESTIL MANUFACTURING		P.O.# X
DRAWN BY: KGH		W.O.# X
DATE: 3/8/2018	SALES: X	FILE NAME:
REFERENCE: X	SCALE: 1:22	50-007-014
QUOTED LEAD TIME: X	QUOTE # X	