

# GAS POWERED ALL TERRAIN PALLET TRUCK - ALL-T-4-GPT-L-HD

\*\*\*ANY ADDITIONS, DELETIONS, OR OMISSIONS MUST BE CORRECTED ON THIS DRAWING AS THIS DRAWING WILL BE CONSIDERED ALL INCLUSIVE\*\*\*  
 APPROX WEIGHT: 1167 lbs.  
 DOES NOT INCLUDE WEIGHT OF POWER OR PACKAGING!!!

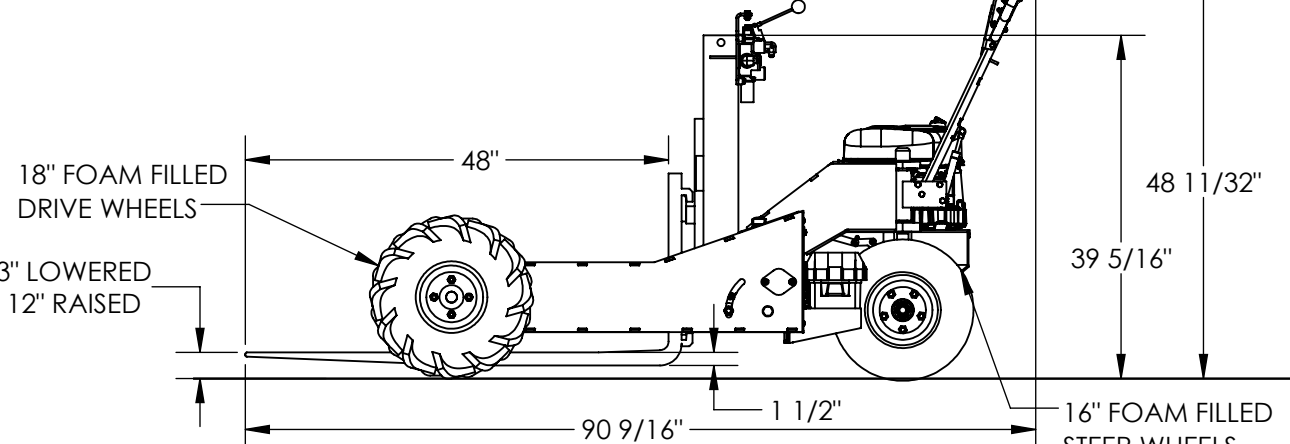
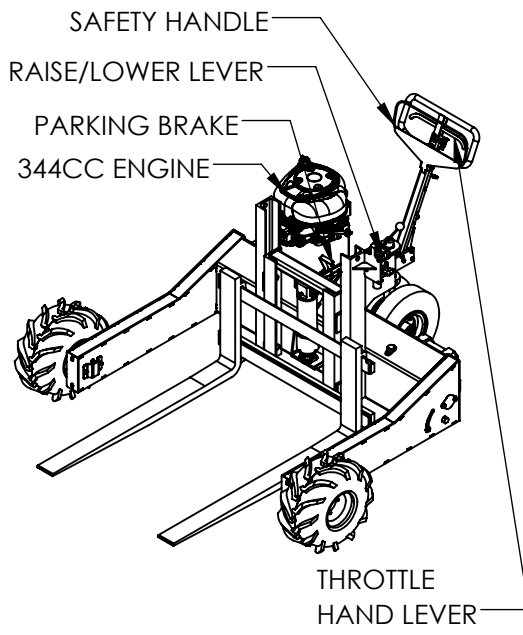
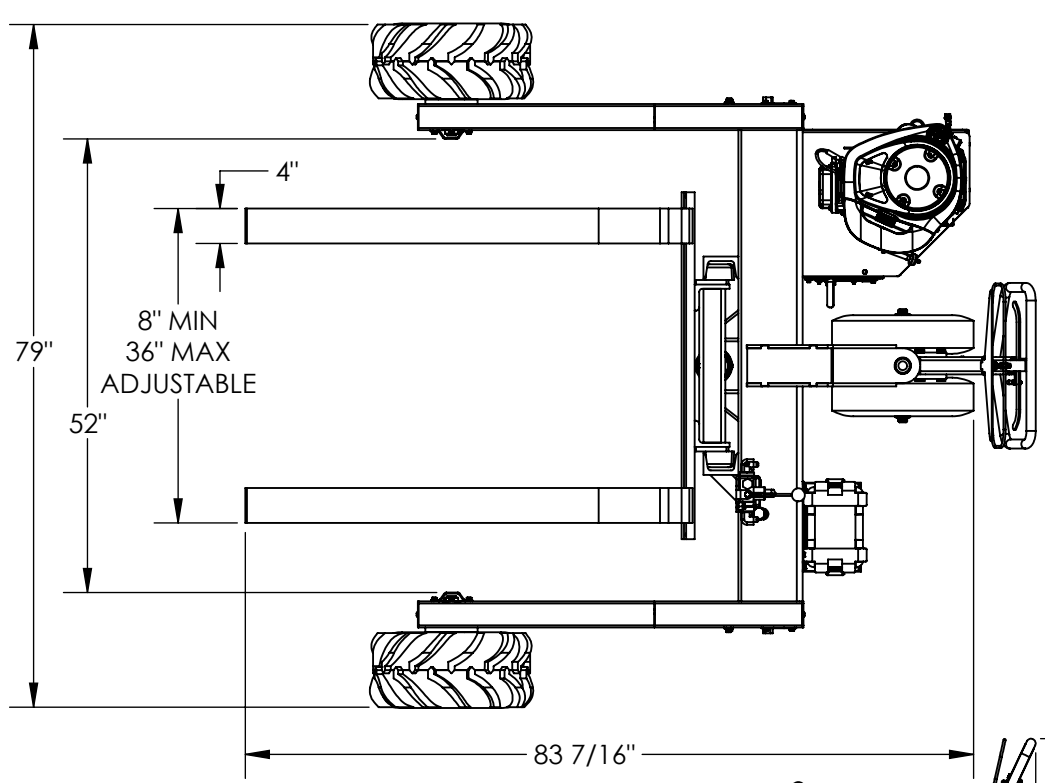

| FOR INTERNAL USE ONLY<br>PROJECT SIGN OFF |  |
|---|--|
| SALES                                     |  |
| ENG.                                      |  |
| FAB.                                      |  |
| POWER                                     |  |

ALL GRAPHICS PROVIDED ARE FOR REFERENCE ONLY. IF CERTAIN DIMENSIONS ARE CRITICAL PLEASE VERIFY THOSE DIMENSIONS WITH YOUR SALESPERSON  
 DIMENSION TOLERANCE ± 1"

**STANDARD FEATURES**  
 MODEL NUMBER IS ALL-T-4-GPT-L-HD  
 CAPACITY IS 4,000 LBS  
 OVERALL WIDTH IS 79"  
 STRADDLE WIDTH IS 52"  
 FORKS ARE ADJUSTABLE FROM 8" TO 36"  
 FORKS ARE 1 1/2" THICK X 4" WIDE X 48" LONG  
 OVERALL LENGTH IS 90 9/16"  
 OVERALL HEIGHT IS 48 11/32"  
 18" FOAM FILLED FRONT WHEELS  
 SAFETY HANDLE WITH FORWARD/NEUTRAL/REVERSE  
 344CC BRIGGS AND STRATTON ENGINE WITH ELECTRIC START  
 HAND LEVER TO CONTROL LIFT/LOWER  
 DURABLE LIQUID PAINT BLUE FINISH

**A P P R O V A L**

I, THE UNDERSIGNED, AGREE THAT THE PRODUCT AS REPRESENTED SATISFIES DESIGN AND DIMENSION REQUIREMENTS. I ALSO ACKNOWLEDGE MY DUTY TO CONFIRM PRODUCT AND INSTALLATION COMPLIANCE WITH ALL APPLICABLE FEDERAL, STATE AND LOCAL REGULATIONS AND STANDARDS.  
**UNITS REQUIRING APPROVAL DRAWINGS OR MODIFIED ARE NON-RETURNABLE**  
 As drawn      As marked

Signed: \_\_\_\_\_ Date: \_\_\_\_\_  
 Printed Name: \_\_\_\_\_

LEAD TIME WILL START UPON RECEIPT OF SIGNED APPROVAL DRAWING

|                      |             |            |
|----------------------|-------------|------------|
| DISTRIBUTOR'S NAME:  |             | P.O.#      |
| VESTIL MANUFACTURING |             | X          |
| DRAWN BY: KGH        |             | W.O.#      |
| DATE: 6/25/2018      |             | X          |
| REFERENCE: X         | SCALE: 1:22 | SALES: X   |
| QUOTED LEAD TIME: X  | QUOTE # X   | FILE NAME: |
|                      |             | 50-007-021 |