

# HAND TRUCK PLATFORM W/ YELLOW URETHANE SOLID FOAM WHEELS

APPROX WEIGHT: 163.17 lbs. DOES NOT INCLUDE WEIGHT OF POWER OR PACKAGING!!!

## - ALUM-P-TB-UFYL

\*\*\* ANY ADDITIONS, DELETIONS, OR OMISSIONS MUST BE CORRECTED ON THIS DRAWING AS THIS DRAWING WILL BE CONSIDERED ALL INCLUSIVE \*\*\*  
 ALL GRAPHICS PROVIDED ARE FOR REFERENCE ONLY. IF CERTAIN DIMENSIONS ARE CRITICAL PLEASE VERIFY THOSE DIMENSIONS WITH YOUR SALESPERSON

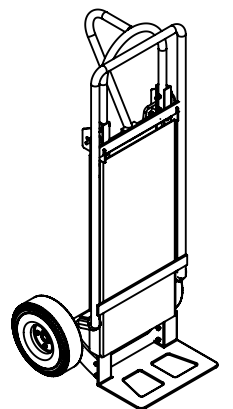
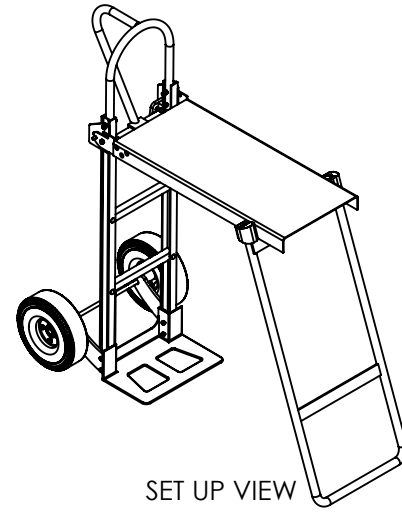
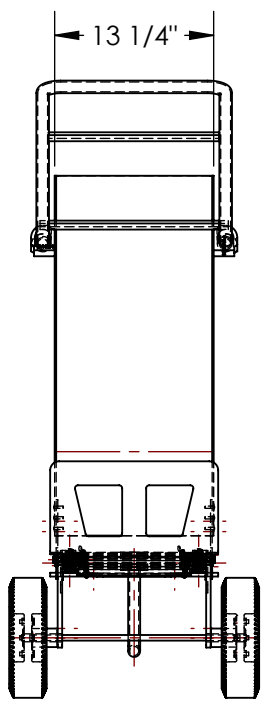
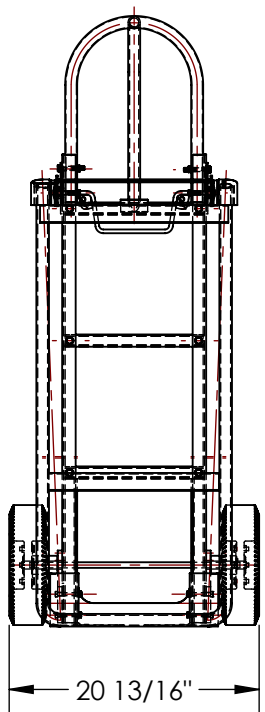
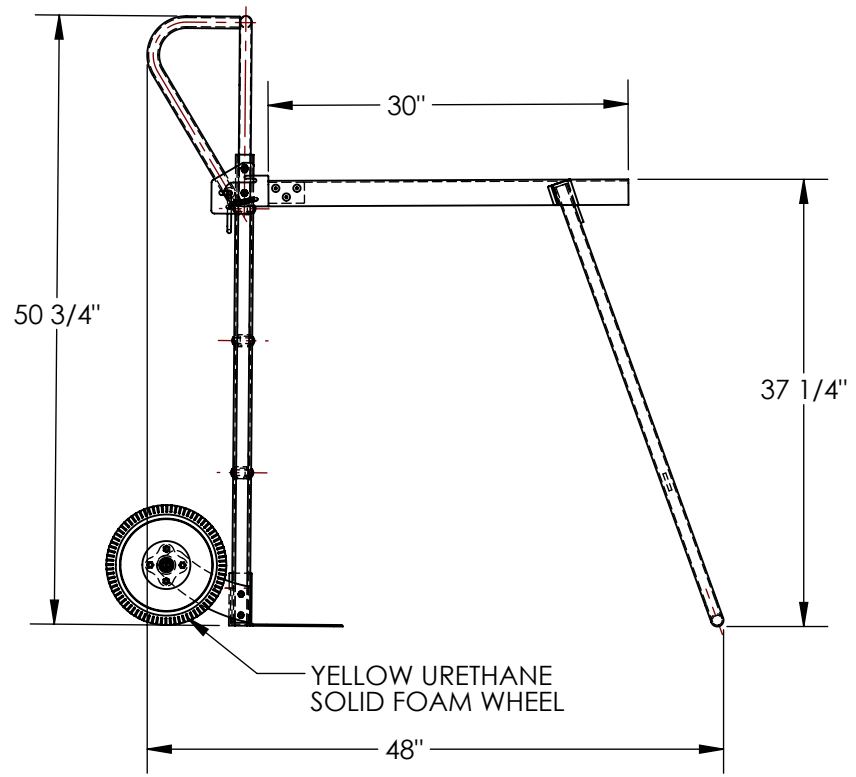

FOR INTERNAL USE ONLY  
PROJECT SIGN OFF

SALES	
ENG.	
FAB.	
POWER	

DIMENSION TOLERANCE ± 1/4"

NOTE:  
SHELF IS NOT LEVEL

### STANDARD FEATURES

- MODEL NUMBER IS ALUM-P-TB-UFYL
- OVERALL WIDTH IS 20 13/16"
- USABLE WIDTH IS 13 1/4"
- OVERALL LENGTH IS 48"
- USABLE LENGTH IS 30"
- OVERALL HEIGHT IS 50 3/4"
- SHELF SIZE IS 13 1/4" W X 30" LG
- MAX CAPACITY OF DOLLY IS 500 LBS.
- MAX CAPACITY OF SHELF IS 100 LBS. EVENLY DISTRIBUTED

### SPECIAL FEATURES

NONE

**APPROVAL**

I, THE UNDERSIGNED, AGREE THAT THE PRODUCT AS REPRESENTED SATISFIES DESIGN AND DIMENSION REQUIREMENTS. I ALSO ACKNOWLEDGE MY DUTY TO CONFIRM PRODUCT AND INSTALLATION COMPLIANCE WITH ALL APPLICABLE FEDERAL, STATE AND LOCAL REGULATIONS AND STANDARDS.

**ANY MODIFIED UNITS ARE NON-RETURNABLE**

[ ] As drawn      [ ] As marked

Signed: \_\_\_\_\_ Date: \_\_\_\_\_

Printed Name: \_\_\_\_\_

*LEAD TIME WILL START UPON RECEIPT OF SIGNED APPROVAL DRAWING*

DISTRIBUTOR'S NAME:		P.O.#
VESTIL MANUFACTURING		X
DRAWN BY: CA		W.O.#
DATE: 06/07/2016		X
REFERENCE: X	SCALE: 1:16	SALES: X
QUOTED LEAD TIME: X	QUOTE #	FILE NAME:
	X	33-007-325