

# ALUMINUM PALLET, SOLID TOP, 4-WAY - AP-ST-4848-4W

APPROX WEIGHT: 54.57 lbs.  
 DOES NOT INCLUDE WEIGHT OF POWER OR PACKAGING!!!

\*\*\* ANY ADDITIONS, DELETIONS, OR OMISSIONS MUST BE CORRECTED ON THIS DRAWING AS THIS DRAWING WILL BE CONSIDERED ALL INCLUSIVE \*\*\*  
 ALL GRAPHICS PROVIDED ARE FOR REFERENCE ONLY. IF CERTAIN DIMENSIONS ARE CRITICAL PLEASE VERIFY THOSE DIMENSIONS WITH YOUR SALESPERSON

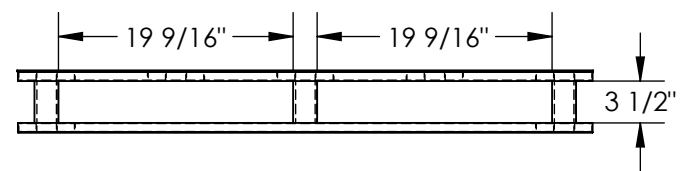
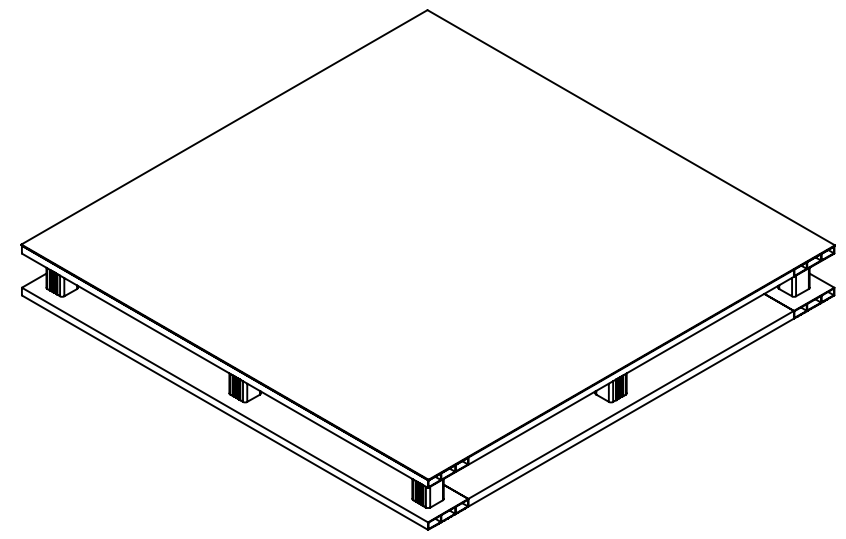
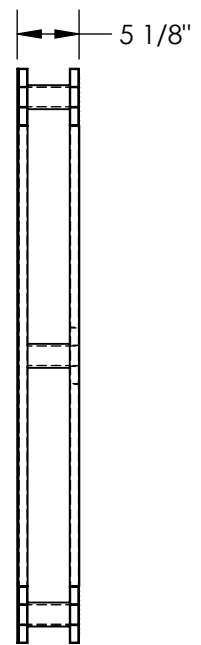
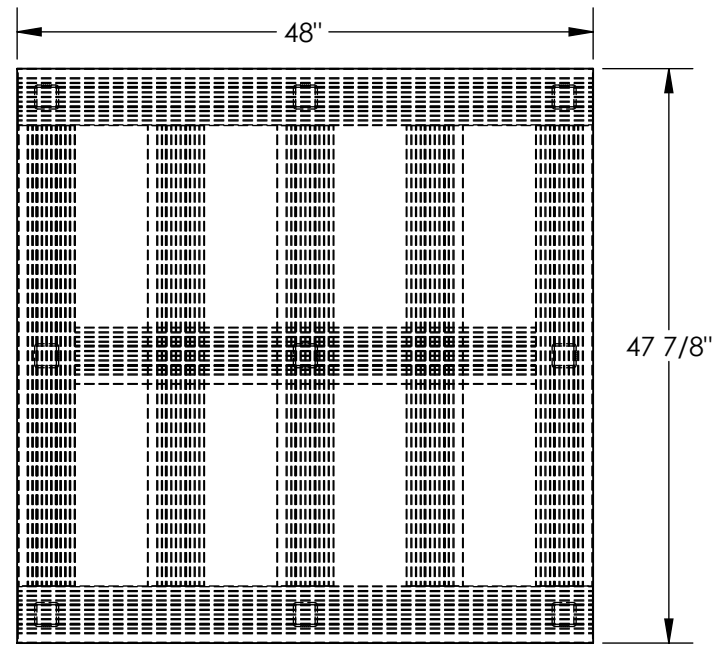

DIMENSION TOLERANCE ± 1/4"

## STANDARD FEATURES

- MODEL NUMBER IS AP-ST-4848-4W
- OVERALL WIDTH IS 47 7/8"
- OVERALL LENGTH IS 48"
- OVERALL HEIGHT IS 5 1/8"
- MAX STATIC CAPACITY IS 6,000 LBS
- MAX DYNAMIC CAPACITY IS 4,000 LBS
- MAX UNSUPPORTED CAPACITY IS 4,000 LBS
- TOP SLAT WIDTH IS 4 3/4"
- WELDED ALUMINUM CONSTRUCTION
- FORK OPENING: 19 9/16" W X 3 1/2" H

## SPECIAL FEATURES

NONE

APPROVAL	I, THE UNDERSIGNED, AGREE THAT THE PRODUCT AS REPRESENTED SATISFIES DESIGN AND DIMENSION REQUIREMENTS. I ALSO ACKNOWLEDGE MY DUTY TO CONFIRM PRODUCT AND INSTALLATION COMPLIANCE WITH ALL APPLICABLE FEDERAL, STATE AND LOCAL REGULATIONS AND STANDARDS.	
	<b>ANY MODIFIED UNITS ARE NON-RETURNABLE</b>	
	[ ] As drawn      [ ] As marked	
	Signed: _____ Date: _____	
Printed Name: _____		
<i>LEAD TIME WILL START UPON RECEIPT OF SIGNED APPROVAL DRAWING</i>		

FOR INTERNAL USE ONLY PROJECT SIGN OFF	
SALES	
ENG.	
FAB.	
POWER	

DISTRIBUTOR'S NAME:		P.O.#
VESTIL MANUFACTURING		X
DRAWN BY: C.CLEMENS		DATE: 03/25/2020
REFERENCE: X		SCALE: 1:16
QUOTED LEAD TIME: X	QUOTE #	FILE NAME:
	X	31-007-300