

APPROACH RAMP - ARX-3654-4

APPROX WEIGHT: 189.34 lbs.
DOES NOT INCLUDE WEIGHT OF POWER OR PACKAGING!!!

ANY ADDITIONS, DELETIONS, OR OMISSIONS MUST BE CORRECTED ON THIS DRAWING AS THIS DRAWING WILL BE CONSIDERED ALL INCLUSIVE

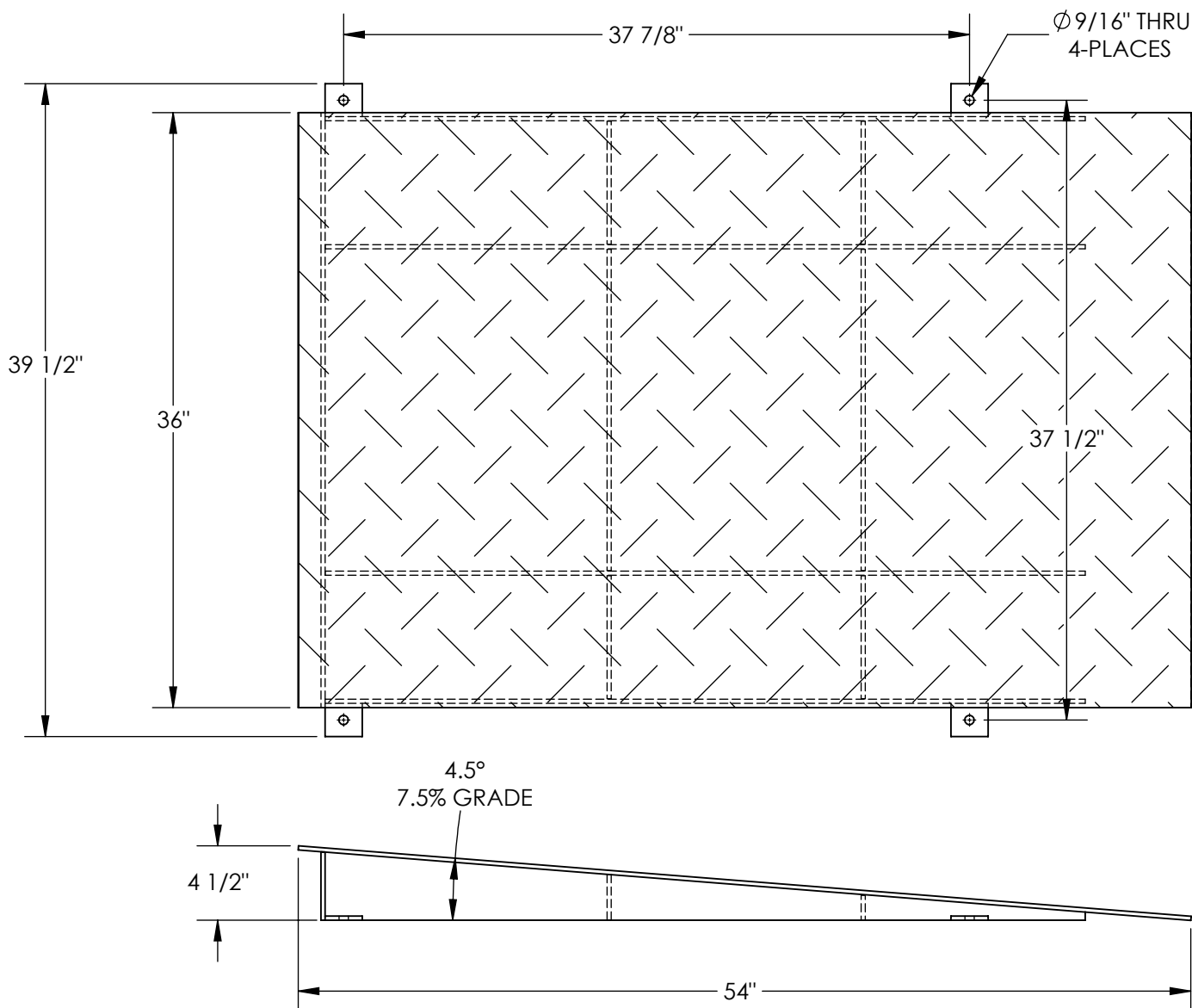

ALL GRAPHICS PROVIDED ARE FOR REFERENCE ONLY. IF CERTAIN DIMENSIONS ARE CRITICAL PLEASE VERIFY THOSE DIMENSIONS WITH YOUR SALESPERSON

STANDARD FEATURES

DIMENSION TOLERANCE ± 1/4"

- MODEL NUMBER IS ARX-3654-4
- OVERALL WIDTH IS 39 1/2"
- USABLE WIDTH IS 36"
- OVERALL LENGTH IS 54"
- OVERALL HEIGHT IS 4 1/2"
- MAX CAPACITY IS 4,000LBS
- RISE 4 1/2"
- SLOPE 4.5° APPROX. 7.5% GRADE
- DURABLE LIQUID PAINT BLUE FINISH

SPECIAL FEATURES

NONE

A P P R O V A L	I, THE UNDERSIGNED, AGREE THAT THE PRODUCT AS REPRESENTED SATISFIES DESIGN AND DIMENSION REQUIREMENTS. I ALSO ACKNOWLEDGE MY DUTY TO CONFIRM PRODUCT AND INSTALLATION COMPLIANCE WITH ALL APPLICABLE FEDERAL, STATE AND LOCAL REGULATIONS AND STANDARDS.	
	ANY MODIFIED UNITS ARE NON-RETURNABLE	
	[] As drawn [] As marked	
	Signed: _____ Date: _____	
	Printed Name: _____	
LEAD TIME WILL START UPON RECEIPT OF SIGNED APPROVAL DRAWING		

FOR INTERNAL USE ONLY PROJECT SIGN OFF		DISTRIBUTOR'S NAME:		P.O.#	
		VESTIL MANUFACTURING		X	
SALES		DRAWN BY: DLS		DATE: 11/7/2014	W.O.#
ENG.		REFERENCE: X		SCALE: 1:10	X
FAB.		QUOTED LEAD TIME: X		QUOTE #	FILE NAME:
POWER				X	27-007-009

IT IS THE END-USER'S RESPONSIBILITY TO DETERMINE IF THE ABOVE RAMP SLOPE WILL FUNCTION WITH THEIR PALLET TRUCK TO LOAD & UNLOAD PRODUCT ONTO THE EHLTX