

BIG FOOT TRAILER STABILIZING JACK - BFSJ-2748-100

APPROX WEIGHT: 149.09 lbs.
 DOES NOT INCLUDE WEIGHT OF POWER OR PACKAGING!!!

*** ANY ADDITIONS, DELETIONS, OR OMISSIONS MUST BE CORRECTED ON THIS DRAWING AS THIS DRAWING WILL BE CONSIDERED ALL INCLUSIVE ***
 ALL GRAPHICS PROVIDED ARE FOR REFERENCE ONLY. IF CERTAIN DIMENSIONS ARE CRITICAL PLEASE VERIFY THOSE DIMENSIONS WITH YOUR SALESPERSON

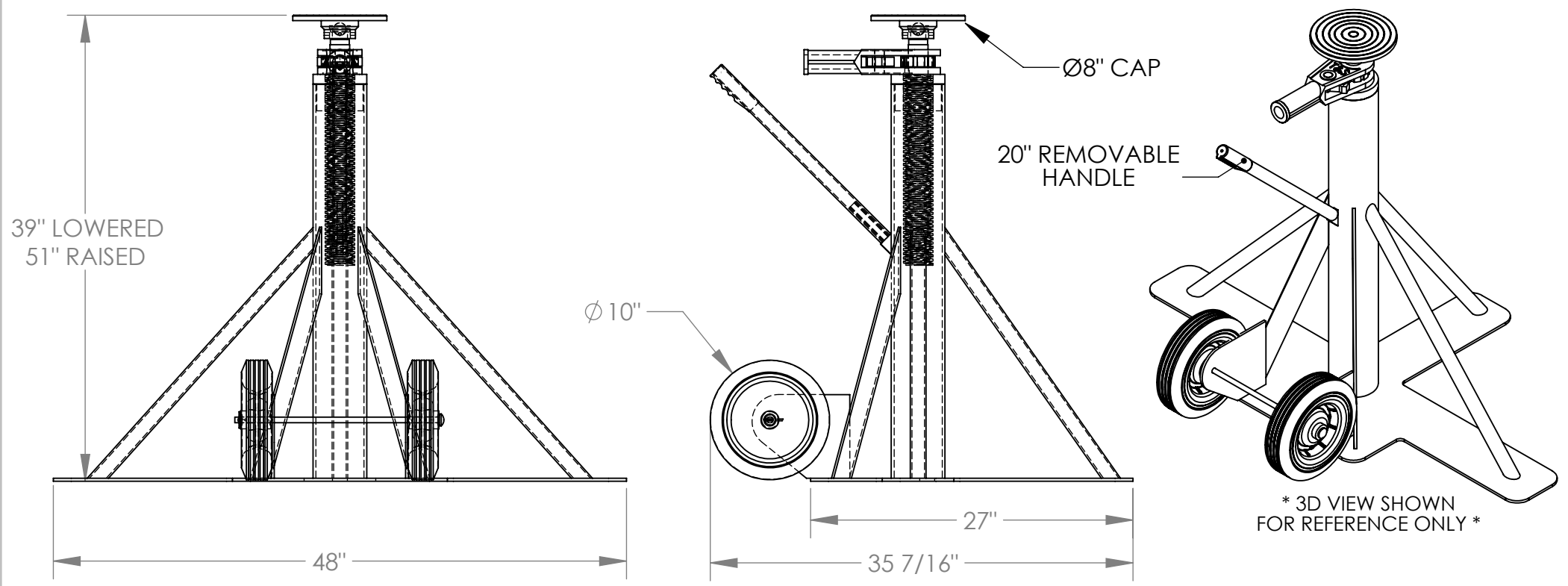

STANDARD FEATURES

- MODEL NUMBER: BFSJ-2748-100
- OVERALL WIDTH: 48"
- OVERALL LENGTH: 35 7/16"
- HANDLE LENGTH: 20"
- SERVICE RANGE: 39" TO 51"
- LIFTING CAPACITY: 50,000 LBS. (25 TONS)
- STATIC CAPACITY: 100,000 LBS. (50 TONS)
- TOP CAP: 8" DIAMETER
- WHEEL SIZE IS Ø10"
- REMOVABLE HANDLE USED TO MOVE & LIFT JACK
- HANDLE LENGTH IS 20"

SPECIAL FEATURES

NONE

DIMENSION TOLERANCE ± 1/4"

I, THE UNDERSIGNED, AGREE THAT THE PRODUCT AS REPRESENTED SATISFIES DESIGN AND DIMENSION REQUIREMENTS. I ALSO ACKNOWLEDGE MY DUTY TO CONFIRM PRODUCT AND INSTALLATION COMPLIANCE WITH ALL APPLICABLE FEDERAL, STATE AND LOCAL REGULATIONS AND STANDARDS.

ANY MODIFIED UNITS ARE NON-RETURNABLE

[] As drawn [] As marked

Signed: _____ Date: _____

Printed Name: _____

LEAD TIME WILL START UPON RECEIPT OF SIGNED APPROVAL DRAWING

APPROVAL

FOR INTERNAL USE ONLY PROJECT SIGN OFF	
SALES	
ENG.	
FAB.	
POWER	

DISTRIBUTOR'S NAME: VESTIL MANUFACTURING		P.O.# X
DRAWN BY: B.NOTHNAGEL DATE: 11/24/2015		W.O.# X
REFERENCE: X	SCALE: 1:12	SALES: X
QUOTED LEAD TIME: X	QUOTE # X	FILE NAME: 13-007-043

MAXIMUM WORKING CAPACITY AT GRADE(%)								
0.00%	0.50%	1.00%	1.50%	2.00%	2.50%	3.00%	3.50%	4.00%
100,000	80,000	66,000	55,000	46,000	41,000	37,000	33,000	29,000