

ECONOMIC PALLET & CONTAINER TRANSPORTERS - C-FC-40

APPROX WEIGHT: 188.97 lbs.
 DOES NOT INCLUDE WEIGHT OF POWER OR PACKAGING!!!

*** ANY ADDITIONS, DELETIONS, OR OMISSIONS MUST BE CORRECTED ON THIS DRAWING AS THIS DRAWING WILL BE CONSIDERED ALL INCLUSIVE ***
 ALL GRAPHICS PROVIDED ARE FOR REFERENCE ONLY. IF CERTAIN DIMENSIONS ARE CRITICAL PLEASE VERIFY THOSE DIMENSIONS WITH YOUR SALESPERSON

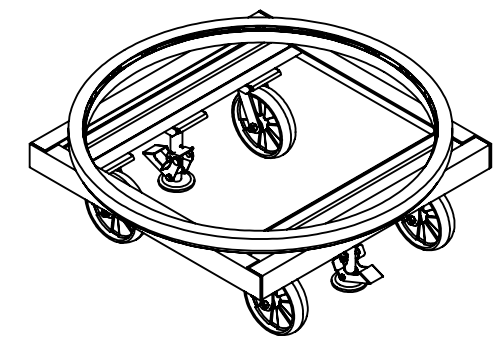
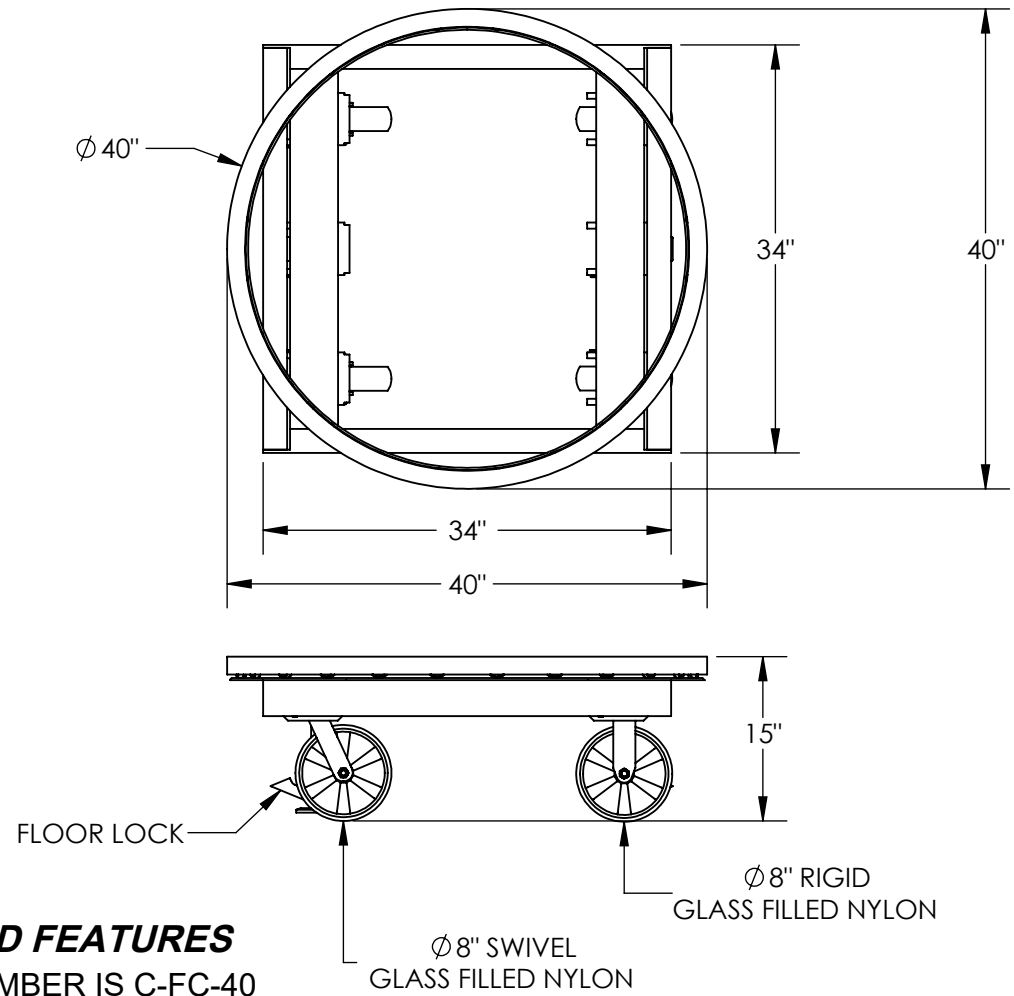

DIMENSION TOLERANCE ± 1/4"

STANDARD FEATURES

- MODEL NUMBER IS C-FC-40
- OVERALL WIDTH IS 40"
- OVERALL LENGTH IS 40"
- PLATFORM WIDTH IS 34"
- PLATFORM LENGTH IS 34"
- OVERALL HEIGHT IS 15"
- MAX CAPACITY IS 4,000LB
- CAROUSEL DIAMETER IS Ø 40"
- CASTERS : Ø8" X 2" GLASS FILLED NYLON
- (2) RIGID & (2) SWIVEL
- TOUGH BAKED IN POWDER COATED BLUE FINISH
- QTY. 2: FLOOR LOCKS

SPECIAL FEATURES

NONE

APPROVAL	I, THE UNDERSIGNED, AGREE THAT THE PRODUCT AS REPRESENTED SATISFIES DESIGN AND DIMENSION REQUIREMENTS. I ALSO ACKNOWLEDGE MY DUTY TO CONFIRM PRODUCT AND INSTALLATION COMPLIANCE WITH ALL APPLICABLE FEDERAL, STATE AND LOCAL REGULATIONS AND STANDARDS.	
	ANY MODIFIED UNITS ARE NON-RETURNABLE	
	[] As drawn [] As marked	
	Signed: _____	Date: _____
Printed Name: _____		
LEAD TIME WILL START UPON RECEIPT OF SIGNED APPROVAL DRAWING		

FOR INTERNAL USE ONLY PROJECT SIGN OFF	
SALES	
ENG.	
FAB.	
POWER	

DISTRIBUTOR'S NAME:		P.O.#
VESTIL MANUFACTURING		X
DRAWN BY: TAC	DATE: 07/16/2010	W.O.#
REFERENCE: X	SCALE: 1:16	X
QUOTED LEAD TIME: X	QUOTE #	FILE NAME:
	X	33-007-075