

FOOT PUMP HYDRAULIC SCISSOR LIFT CART - CART-1000-2040-FP

APPROX WEIGHT: 318.97 lbs.
 DOES NOT INCLUDE WEIGHT OF POWER OR PACKAGING!!!

*** ANY ADDITIONS, DELETIONS, OR OMISSIONS MUST BE CORRECTED ON THIS DRAWING AS THIS DRAWING WILL BE CONSIDERED ALL INCLUSIVE ***
 ALL GRAPHICS PROVIDED ARE FOR REFERENCE ONLY. IF CERTAIN DIMENSIONS ARE CRITICAL PLEASE VERIFY THOSE DIMENSIONS WITH YOUR SALESPERSON

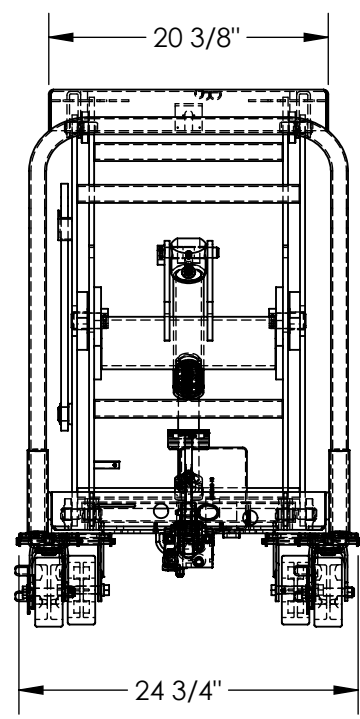
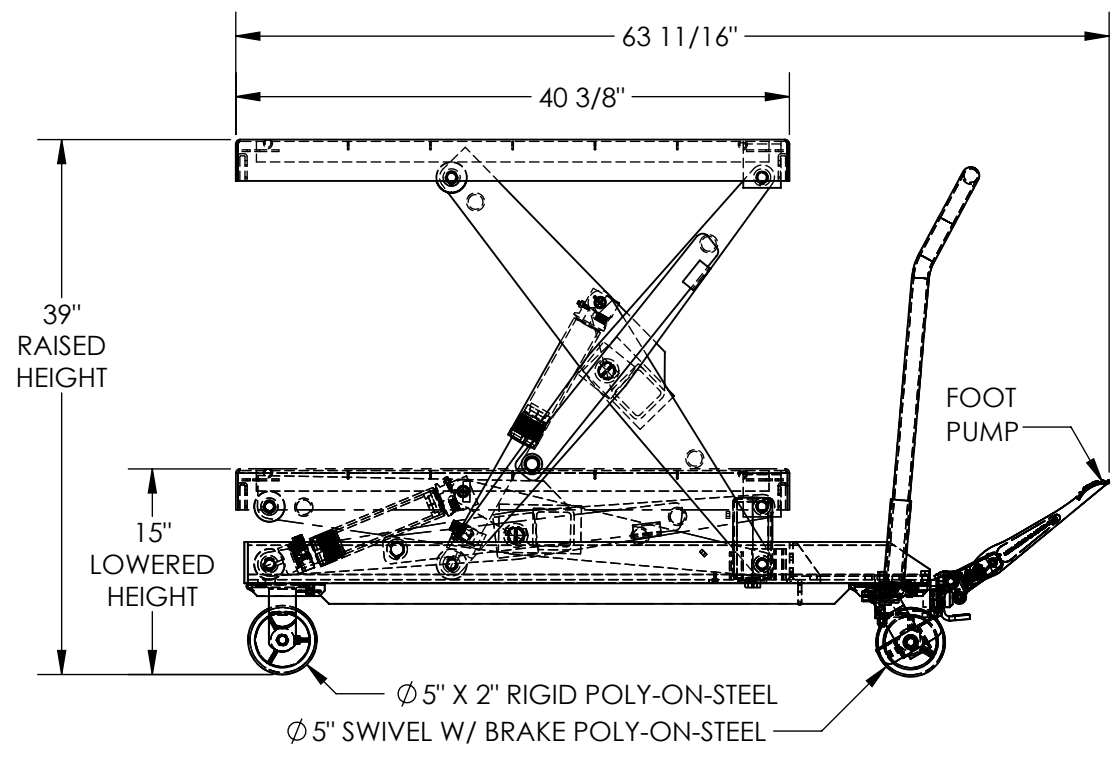

DECK TOLERANCE $\pm 1/2"$
 TABLE HEIGHT TOLERANCES $\pm 1/2"$
 DECK FLATNESS $\pm 1/4"$

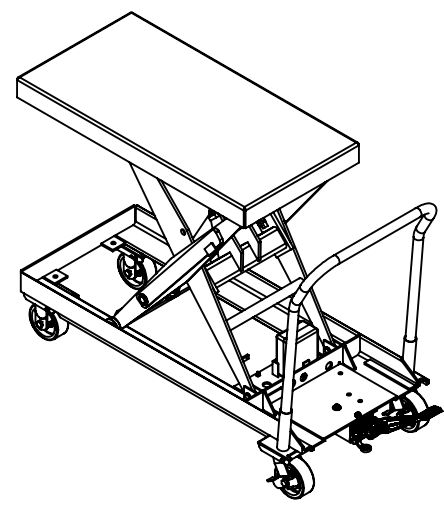

DIMENSION TOLERANCE $\pm 1/4"$

STANDARD FEATURES

- MODEL NUMBER IS CART-1000-2040-FP
- DECK WIDTH IS 20 3/8"
- DECK LENGTH IS 40 3/8"
- RAISED HEIGHT IS 39"
- LOWERED HEIGHT IS 15"
- Ø5" X 2" RIGID POLY-ON-STEEL CASTERS
- Ø5" X 2" SWIVEL POLY-ON-STEEL CASTERS W/ BRAKE
- TABLE CAPACITY (EVENLY DISTRIBUTED)
- MAX CAPACITY IS 1,000 LBS
- SAFETY MAINTENANCE PROPS, DISPLACEMENT
- STYLE CYLINDERS INSTALLED ROD DOWN
- EMERGENCY SAFETY STOP HYDRAULIC FUSES
- TWO SPEED AUTO SHIFTING MANUAL FOOT PUMP
- NUMBER OF PUMPS TO RAISE TABLE
- LOW PRESSURE: 10
- HIGH PRESSURE: 28
- DURABLE LIQUID PAINT BLUE FINISH

SPECIAL FEATURES

NONE

**A
P
P
R
O
V
A
L**

I, THE UNDERSIGNED, AGREE THAT THE PRODUCT AS REPRESENTED SATISFIES DESIGN AND DIMENSION REQUIREMENTS. I ALSO ACKNOWLEDGE MY DUTY TO CONFIRM PRODUCT AND INSTALLATION COMPLIANCE WITH ALL APPLICABLE FEDERAL, STATE AND LOCAL REGULATIONS AND STANDARDS.

UNITS REQUIRING APPROVAL DRAWINGS OR MODIFIED ARE NON-RETURNABLE

[] As drawn [] As marked

Signed: _____ Date: _____

Printed Name: _____

LEAD TIME WILL START UPON RECEIPT OF SIGNED APPROVAL DRAWING

DISTRIBUTOR'S NAME:		P.O.#
VESTIL MANUFACTURING		X
W.O.#		X
DRAWN BY: CRA	DATE: 09/29/2017	SALES: X
REFERENCE: X	SCALE: 1:14	FILE NAME:
QUOTED LEAD TIME: X	QUOTE # X	01-007-357