

SCISSOR HYDRAULIC ELEVATING CART, CART-1750

****Any additions, deletions or omissions must be corrected on this drawing, as this drawing will be considered all inclusive.****

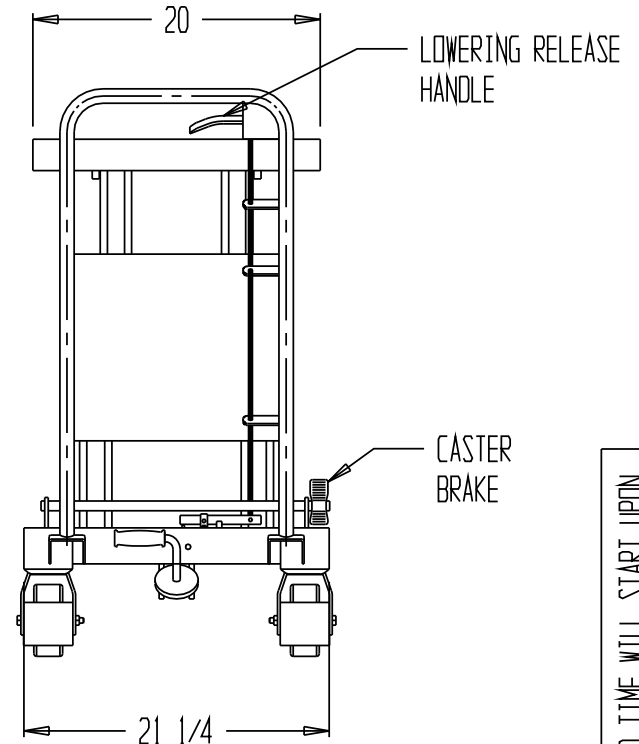
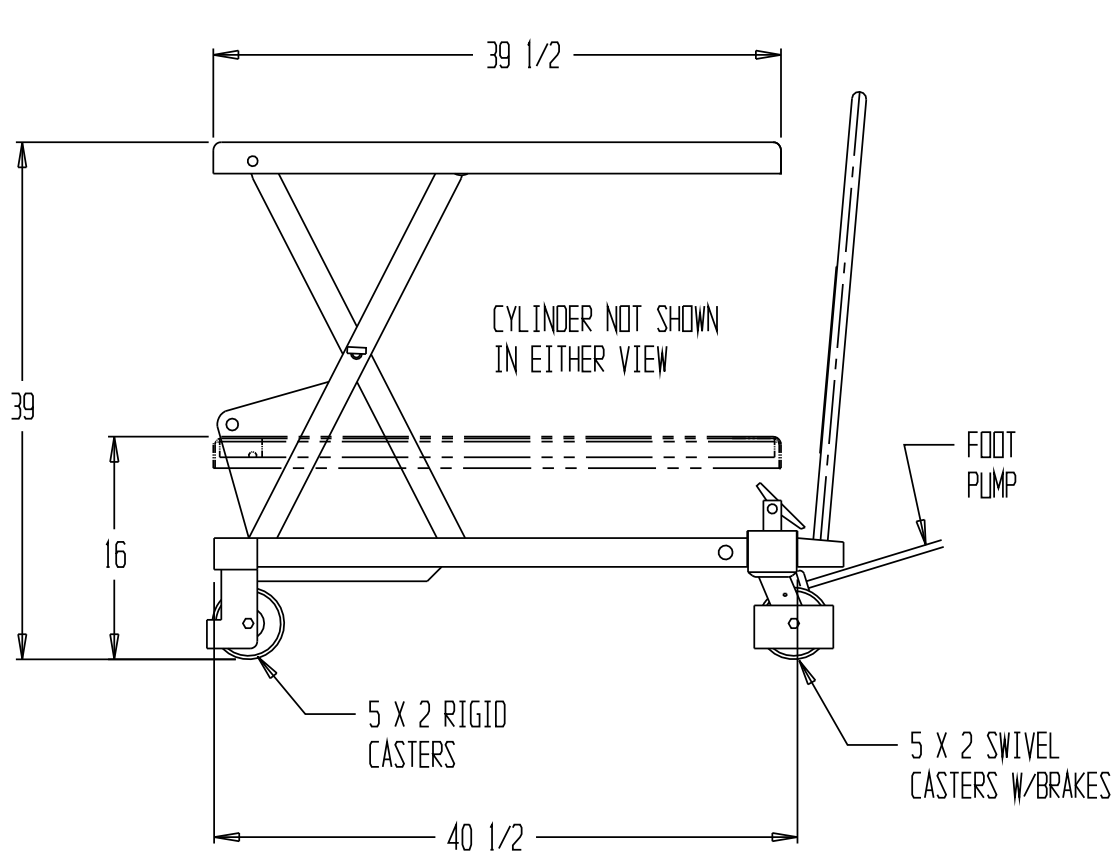

LEAD TIME WILL START UPON RECEIPT OF SIGNED APPROVAL DRAWING

STANDARD FEATURES

- MODEL NUMBER: CART-1750
- CAPACITY: 1,750 LBS.
- PLATFORM WIDTH: 20"
- PLATFORM LENGTH: 39 1/2"
- PLATFORM RAISED HEIGHT: 39"
- PLATFORM LOWERED HEIGHT: 16"
- STANDARD SINGLE SPEED FOOT PUMP
- FULL HEIGHT = 70 PUMPS

SPECIAL FEATURES

NONE

****SPECIAL UNITS ARE NON-RETURNABLE
*AVAILABLE AT ADDITIONAL COSTS**

***** ALL GRAPHICS PROVIDED ARE FOR REFERENCE ONLY.
IF CERTAIN DIMENSIONS ARE CRITICAL PLEASE VERIFY
THOSE DIMENSIONS WITH YOUR SALESPERSON. *****

APPROVAL

I, the undersigned, hereby approve this print
 As drawn As marked

This includes my approval of design & dimensions.

Signed: _____

Date: _____

DISTRIBUTOR'S NAME:		P.O.#:
VESTIL MANUFACTURING		-
DRAWN BY: SR	DATE: 2-22-06	W.O.#:
REFERENCE:		-
SCALE: 1:14		DRWG./FILE NAME:
		CART-1750