

DC POWERED SCISSOR CART, CART-23-10-DC

Any additions, deletions or omissions must be corrected on this drawing, as this drawing will be considered all inclusive.

All graphics provided are for reference only. If certain dimensions are critical please verify those dimensions with your salesperson

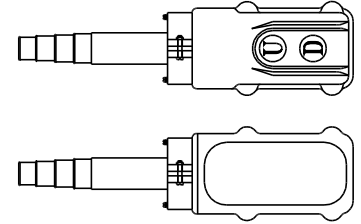
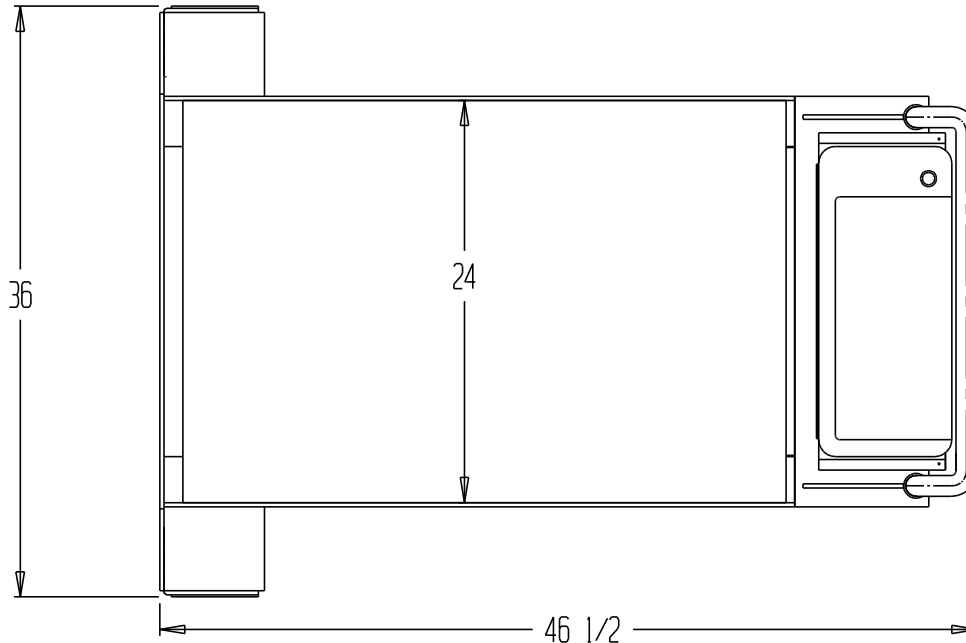

*INCLUDES A 2-BUTTON HAND PENDANT CONTROL

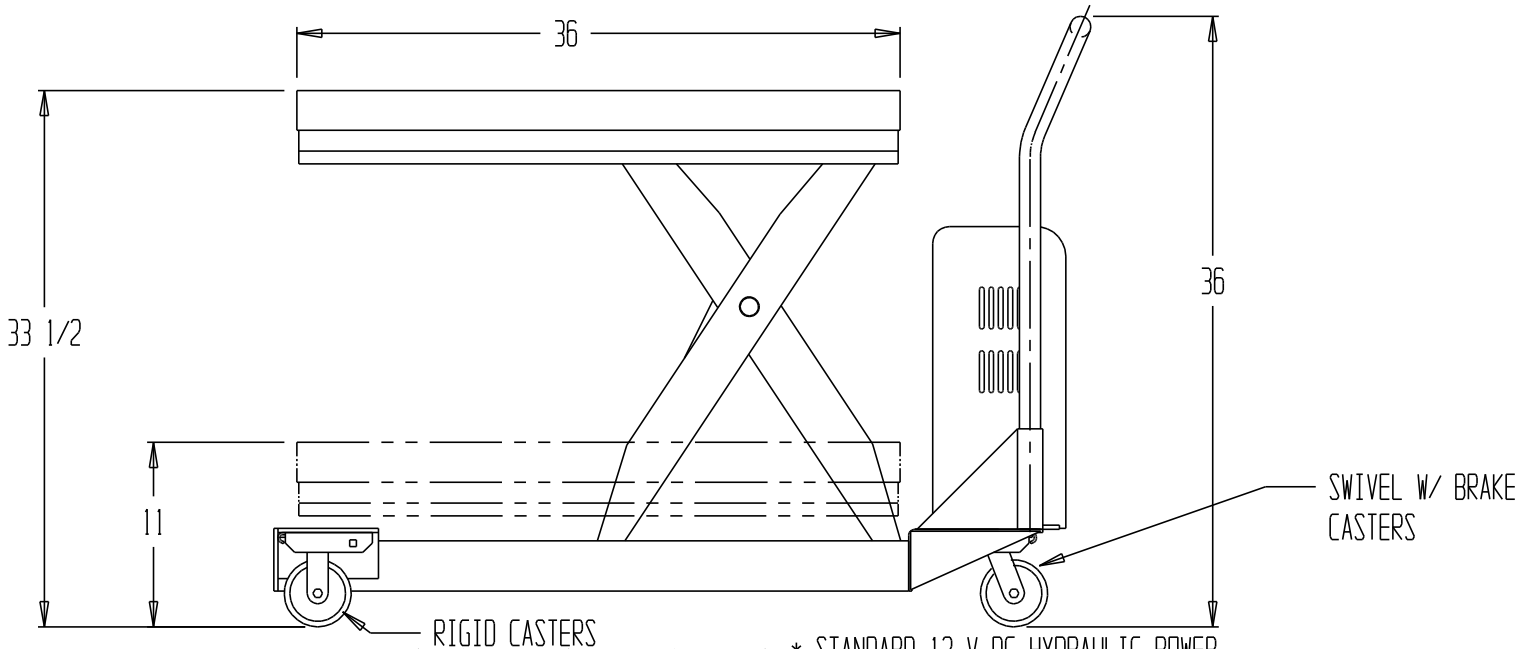

STANDARD FEATURES

- MODEL NUMBER: CART-23-10-DC
- CAPACITY: 1,000 LBS.
- PLATFORM WIDTH: 24"
- PLATFORM LENGTH: 36"
- PLATFORM LOWERED HEIGHT: 11"
- PLATFORM RAISED HEIGHT: 33 1/2"
- OVERALL WIDTH: 36"
- OVERALL LENGTH: 46 1/2"
- CASTERS: TWO 4 X 2 PHENOLIC SWIVEL W/ BRAKE
TWO 4 X 2 PHENOLIC RIGID

PLEASE CIRCLE SPECIFICATIONS:

POWER	<input type="checkbox"/> AC	<input checked="" type="checkbox"/> DC (12V)	<input type="checkbox"/> AIR/OIL	
MOTOR VOLTAGE	<input type="checkbox"/> 115	<input type="checkbox"/> 200	<input type="checkbox"/> 230	<input type="checkbox"/> 460
DEDICATED CIRCUIT REQUIRED				
MOTOR PHASE	<input type="checkbox"/> SINGLE		<input type="checkbox"/> THREE	
CONTROL	<input type="checkbox"/> HAND		<input checked="" type="checkbox"/> *FOOT	
BATTERY CHRG.	<input type="checkbox"/> REMOTE		<input checked="" type="checkbox"/> ON-BOARD	
*CHRG. INDICATOR	<input type="checkbox"/> YES		<input type="checkbox"/> NO	

* STANDARD 12 V DC HYDRAULIC POWER
RAISE & LOWER BUTTONS IN TOP OF POWER UNIT

PRODUCTION WILL START UPON RECEIPT OF SIGNED APPROVAL DRAWING

SPECIAL FEATURES

NONE

**SPECIAL UNITS ARE NON-RETURNABLE
*AVAILABLE AT ADDITIONAL COSTS

All graphics provided are for reference only. If certain dimensions are critical please verify those dimensions with your salesperson

I, THE UNDERSIGNED, AGREE THAT THE PRODUCT AS REPRESENTED SATISFIES DESIGN & DIMENSION REQUIREMENTS. I ALSO ACKNOWLEDGE MY DUTY TO CONFIRM PRODUCT & INSTALLATION COMPLIANCE WITH ALL APPLICABLE FEDERAL, STATE AND LOCAL REGULATIONS & STANDARDS.
UNITS REQUIRING APPROVAL DRAWINGS OR MODIFIED ARE NON-RETURNABLE
() As drawn () As marked

Signed: _____ Date: _____
Printed Name _____
LEAD TIME WILL START UPON RECEIPT OF SIGNED APPROVAL DRAWING

DISTRIBUTOR'S NAME: VESTIL MFG		P.O.#: -
DRAWN BY: _____		W.O.#: -
DATE: -	SALES: -	
REFERENCE: -	SCALE: -	DRWG./FILE NAME: CART-23-10-DC
QUOTED LEADTIME: -	QUOTE #: -	