

# COUNTER-BALANCED STACKER - CBS-56-1-DC

APPROX WEIGHT: 1147.38 lbs.  
 DOES NOT INCLUDE WEIGHT OF POWER OR PACKAGING!!!

\*\*\* ANY ADDITIONS, DELETIONS, OR OMISSIONS MUST BE CORRECTED ON THIS DRAWING AS THIS DRAWING WILL BE CONSIDERED ALL INCLUSIVE \*\*\*

ALL GRAPHICS PROVIDED ARE FOR REFERENCE ONLY. IF CERTAIN DIMENSIONS ARE CRITICAL PLEASE VERIFY THOSE DIMENSIONS WITH YOUR SALESPERSON

## STANDARD FEATURES

MODEL NUMBER: CBS-56-1-DC

OVERALL LENGTH: 62 13/16"  
 OVERALL WIDTH: 27 1/2"  
 OVERALL HEIGHT: 71 7/8"

LOWERED HEIGHT OF FORK IS 1 1/4"  
 RAISED HEIGHT OF FORK IS 56"

FORK ADJUSTMENT RANGE IS 4" TO 19"

FORK SIZE IS  
 3" WIDTH X 25 1/2" LENGTH X 1" THICKNESS

UNIFORM CAPACITY IS 1,000 LB  
 AT LOAD CENTER 12"

CASTERS:  
 FRONT: 6" X 2" GFN WHEELS  
 REAR: 6" X 2" GFN SWIVEL CASTERS WITH BRAKES

POWER UNIT: 12 V DC WITH ON-BOARD  
 CHARGER & BATTERY CHARGE INDICATOR  
 CONTROL: HAND

DURABLE LIQUID PAINT BLUE FINISH

## SPECIAL FEATURES

NONE

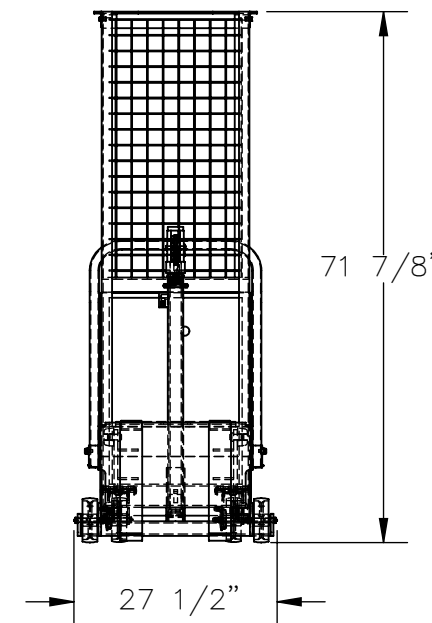
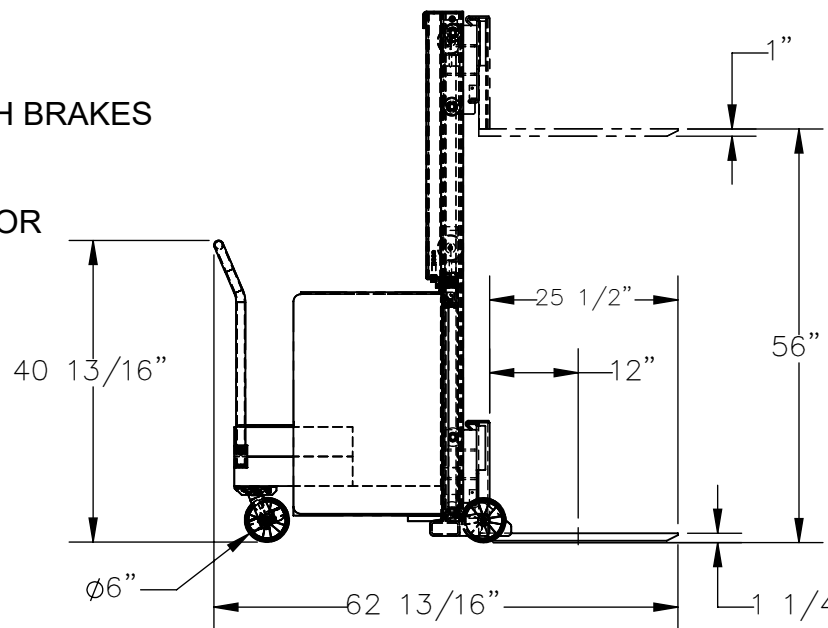
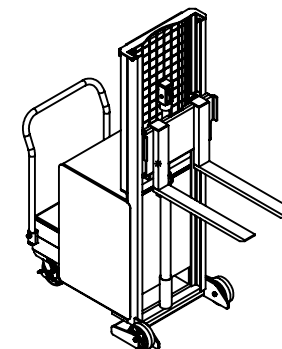
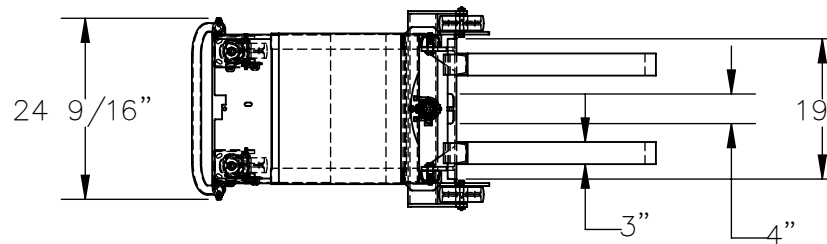

DIMENSION TOLERANCE ± 1/4"

APPROVAL

I, THE UNDERSIGNED, AGREE THAT THE PRODUCT AS REPRESENTED SATISFIES DESIGN AND DIMENSION REQUIREMENTS. I ALSO ACKNOWLEDGE MY DUTY TO CONFIRM PRODUCT AND INSTALLATION COMPLIANCE WITH ALL APPLICABLE FEDERAL, STATE AND LOCAL REGULATIONS AND STANDARDS.

**ANY MODIFIED UNITS ARE NON-RETURNABLE**

As drawn     As marked

Signed: \_\_\_\_\_ Date: \_\_\_\_\_

Printed Name: \_\_\_\_\_

LEAD TIME WILL START UPON RECEIPT OF SIGNED APPROVAL DRAWING

FOR INTERNAL USE ONLY  
 PROJECT SIGN OFF

SALES	
ENG.	
FAB.	
POWER	

DISTRIBUTOR'S NAME:

**VESTIL MANUFACTURING**

DRAWN BY: SJA

DATE: 9/20/2016

REFERENCE: X

SCALE: 1:26

QUOTED LEAD TIME: X

QUOTE # X

P.O.# X

W.O.# X

SALES: X

FILE NAME:

21-007-063