

FORK MOUNTED RUG-RAM - CRF-48

APPROX WEIGHT: 273.99 lbs.
 DOES NOT INCLUDE WEIGHT OF POWER OR PACKAGING!!!

*** ANY ADDITIONS, DELETIONS, OR OMISSIONS MUST BE CORRECTED ON THIS DRAWING AS THIS DRAWING WILL BE CONSIDERED ALL INCLUSIVE ***

ALL GRAPHICS PROVIDED ARE FOR REFERENCE ONLY. IF CERTAIN DIMENSIONS ARE CRITICAL PLEASE VERIFY THOSE DIMENSIONS WITH YOUR SALESPERSON

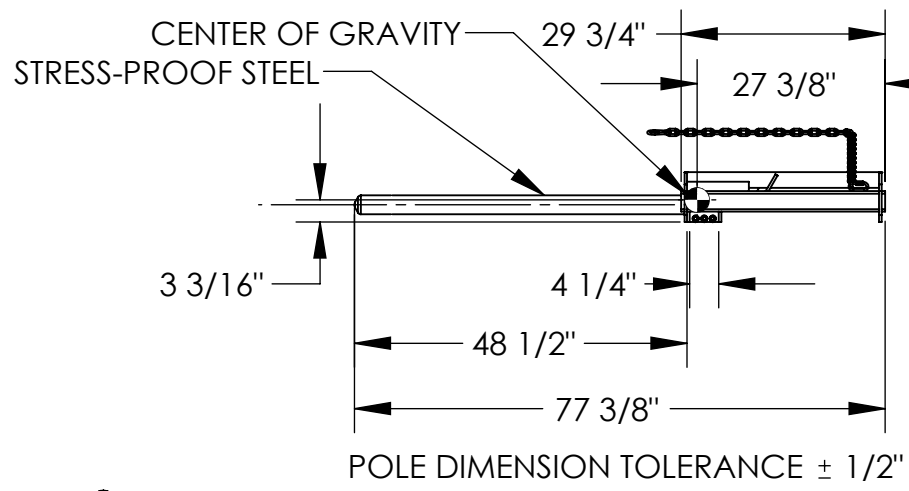
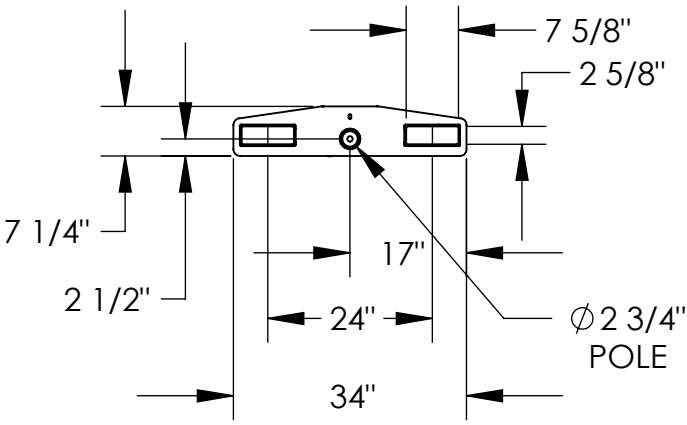

SAFETY RESTRAINT
 CHAIN TO SECURE
 UNIT TO FORK TRUCK

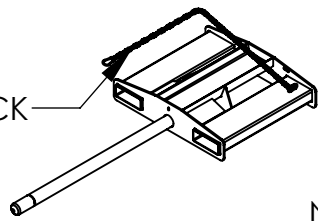

3-D VIEW
 FOR REFERENCE

NOTE: NEVER EXCEED LOAD CENTER RATING PER
 FORK TRUCK MANUFACTURER'S GUIDELINES.
 DO NOT USE THIS FORK TRUCK ATTACHMENT
 IF LOAD WILL EXCEED FORK TRUCK
 MANUFACTURER'S LOAD CENTER RATING.

HORIZONTAL CENTER OF GRAVITY: 27 3/8"
 VERTICAL CENTER OF GRAVITY: 3 3/16"
 LOST LOAD: 274 LBS. (APPROX.)
 MINIMUM EFFECTIVE THICKNESS= LESS THAN 1"

STANDARD FEATURES

- MODEL NUMBER: CRF-48
- CAPACITY: 2,500 LBS. UNIFORM CAPACITY
- POLE LENGTH: 48 1/2"
- OVERALL LENGTH: 77 3/8"
- POLE DIAMETER: 2 3/4"
- FORK POCKETS ARE 7 5/8" W x 2 5/8" H
- USABLE ON 24" FORK CENTERS
- WITH SAFETY CHAIN TO SECURE TO THE UNIT TO THE MAST OF THE FORK TRUCK
- DURABLE LIQUID PAINT
- BLUE FINISH ON FRAME

SPECIAL FEATURES

NONE

A P P R O V A L	I, THE UNDERSIGNED, AGREE THAT THE PRODUCT AS REPRESENTED SATISFIES DESIGN AND DIMENSION REQUIREMENTS. I ALSO ACKNOWLEDGE MY DUTY TO CONFIRM PRODUCT AND INSTALLATION COMPLIANCE WITH ALL APPLICABLE FEDERAL, STATE AND LOCAL REGULATIONS AND STANDARDS.	
	UNITS REQUIRING APPROVAL DRAWINGS OR MODIFIED ARE NON-RETURNABLE	
	[] As drawn [] As marked	
	Signed: _____	Date: _____
Printed Name: _____		
<i>LEAD TIME WILL START UPON RECEIPT OF SIGNED APPROVAL DRAWING</i>		

DISTRIBUTOR'S NAME:		P.O.#
VESTIL MANUFACTURING		X
		W.O.#
DRAWN BY: PAK	DATE: 10/13/2023	SALES: X
REFERENCE: X	SCALE: 1:28	FILE NAME:
QUOTED LEAD TIME: X	QUOTE # X	08-007-495