

PALLET RACK DRUM CRADLE DRIP PAN - DRK-PRDC-DPN

APPROX WEIGHT: 3.53 lbs.
 DOES NOT INCLUDE WEIGHT OF POWER OR PACKAGING!!!

ANY ADDITIONS, DELETIONS, OR OMISSIONS MUST BE CORRECTED ON THIS DRAWING AS THIS DRAWING WILL BE CONSIDERED ALL INCLUSIVE

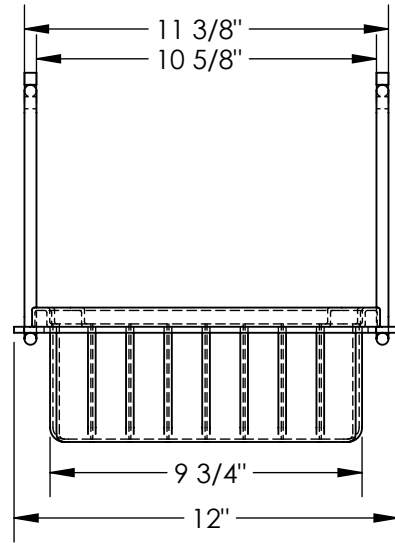
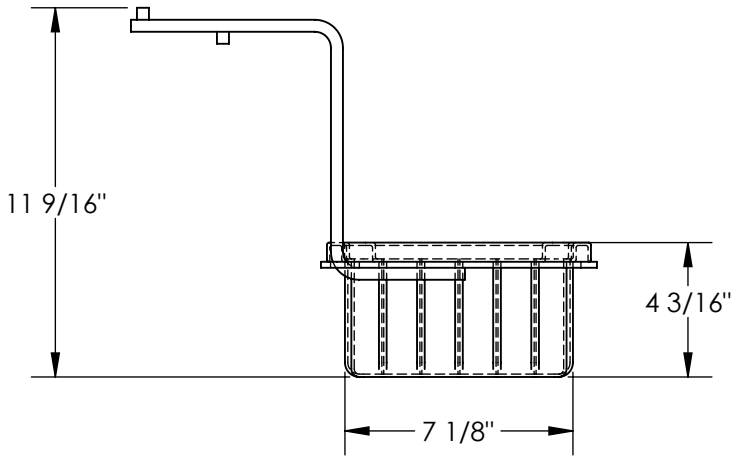
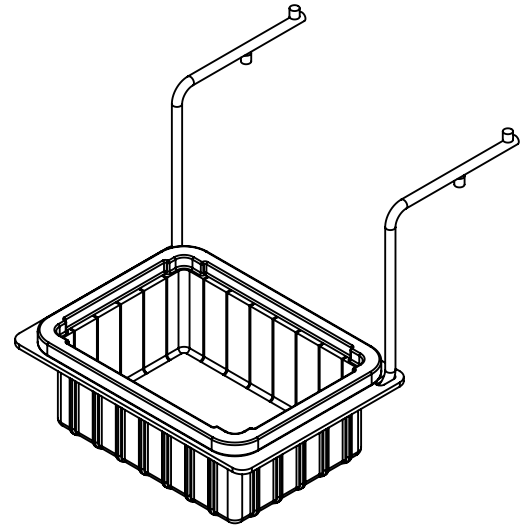
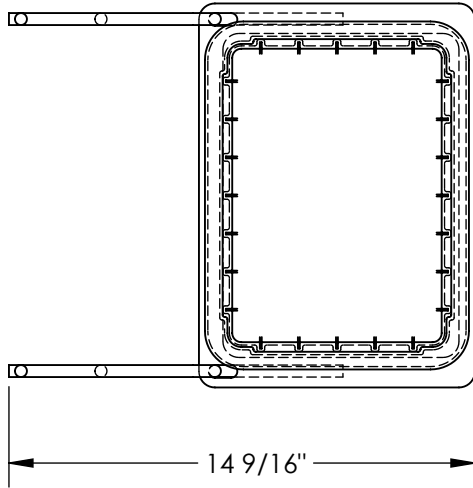

| FOR INTERNAL USE ONLY PROJECT SIGN OFF | |
|---|--|
| SALES | |
| ENG. | |
| FAB. | |
| POWER | |

ALL GRAPHICS PROVIDED ARE FOR REFERENCE ONLY. IF CERTAIN DIMENSIONS ARE CRITICAL PLEASE VERIFY THOSE DIMENSIONS WITH YOUR SALESPERSON

DIMENSION TOLERANCE ± 1/4"

STANDARD FEATURES

- MODEL NUMBER IS DRK-PRDC-DPN
- OVERALL WIDTH IS 12"
- USABLE WIDTH IS 9 3/4"
- OVERALL LENGTH IS 14 9/16"
- USABLE LENGTH IS 7 1/8"
- OVERALL HEIGHT IS 11 9/16"

SPECIAL FEATURES

NONE

**A
P
P
R
O
V
A
L**

I, THE UNDERSIGNED, AGREE THAT THE PRODUCT AS REPRESENTED SATISFIES DESIGN AND DIMENSION REQUIREMENTS. I ALSO ACKNOWLEDGE MY DUTY TO CONFIRM PRODUCT AND INSTALLATION COMPLIANCE WITH ALL APPLICABLE FEDERAL, STATE AND LOCAL REGULATIONS AND STANDARDS.

ANY MODIFIED UNITS ARE NON-RETURNABLE

As drawn As marked

Signed: _____ Date: _____

Printed Name: _____

LEAD TIME WILL START UPON RECEIPT OF SIGNED APPROVAL DRAWING

| | | |
|-----------------------------|---------|----------------|
| DISTRIBUTOR'S NAME: | | P.O.# |
| VESTIL MANUFACTURING | | X |
| | | W.O.# |
| DRAWN BY: C.CLEMENS | | X |
| DATE: 1/11/17 | | SALES: |
| REFERENCE: X | | FILE NAME: |
| SCALE: 1:6 | | |
| QUOTED LEAD TIME: X | QUOTE # | 40-007-093-001 |
| | X | |