

DRUM POSITIONER - DRUM-P-30

APPROX WEIGHT: 290.21 lbs.
DOES NOT INCLUDE WEIGHT OF POWER OR PACKAGING!!!

*** ANY ADDITIONS, DELETIONS, OR OMISSIONS MUST BE CORRECTED ON THIS DRAWING AS THIS DRAWING WILL BE CONSIDERED ALL INCLUSIVE ***

ALL GRAPHICS PROVIDED ARE FOR REFERENCE ONLY. IF CERTAIN DIMENSIONS ARE CRITICAL PLEASE VERIFY THOSE DIMENSIONS WITH YOUR SALESPERSON

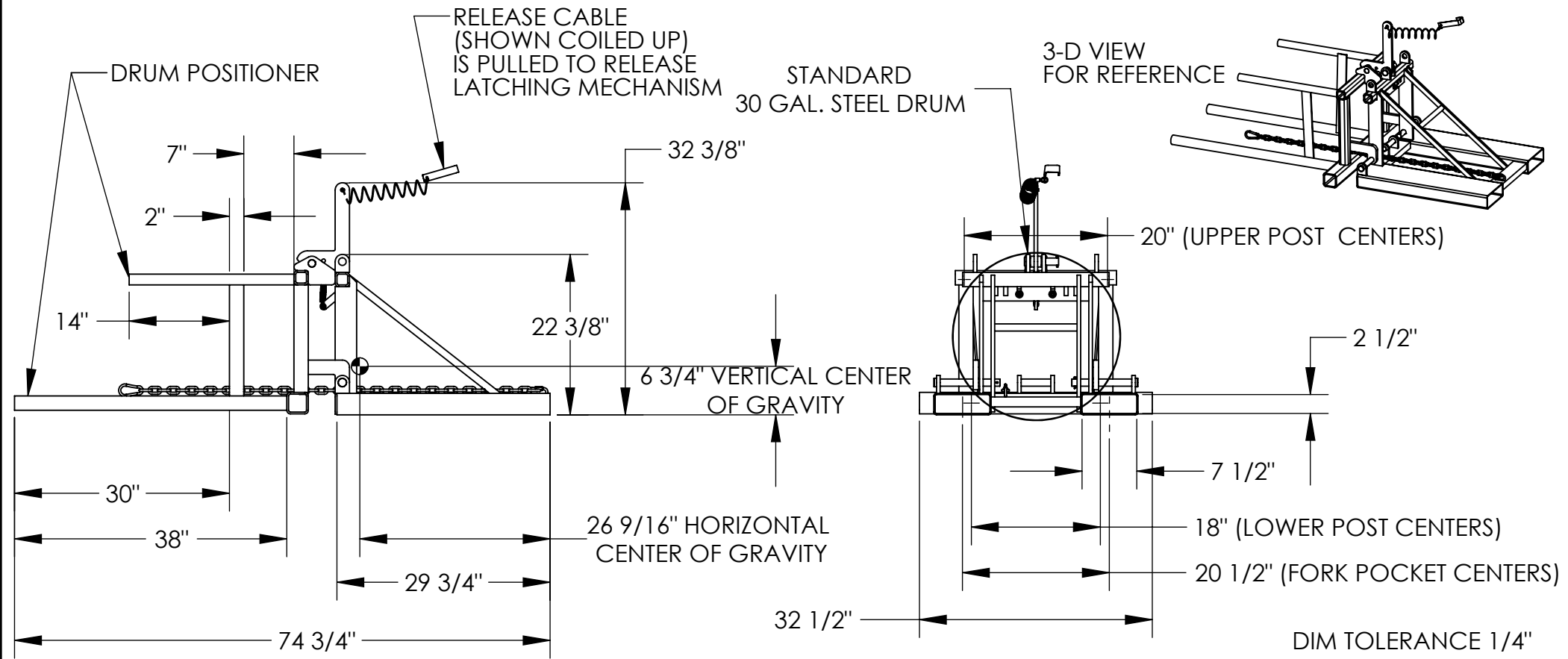

STANDARD FEATURES

- MODEL NUMBER IS DRUM-P-30
- CAPACITY IS 800 LBS.
- OVERALL WIDTH IS 32 1/2"
- OVERALL LENGTH IS 74 3/4"
- USABLE LENGTH IS 38"
- OVERALL HEIGHT IS 32 3/8"
- USABLE FORK POCKETS ARE 7 1/2" W X 2 1/2" H
- FORK POCKETS ARE ON 20 1/2" CENTERS
- LOST LOAD IS 292 LBS. (APPROX)
- EFFECTIVE THICKNESS IS FORK LENGTH MINUS 29 3/4"
- FRAME:
 - TOUGH BAKED IN POWDER COAT BLUE FINISH
- POSITIONER & LATCH HANDLE:
 - TOUGH BAKED IN POWDER COAT YELLOW FINISH

SPECIAL FEATURES

NONE

NEVER EXCEED LOAD CENTER RATING PER FORK TRUCK MANUFACTURER'S GUIDELINES. DO NOT USE THIS FORK TRUCK ATTACHEMENT IF LOAD WILL EXCEED FORK TRUCK MANUFACTURER'S LOAD CENTER RATING.

A P P R O V A L

I, THE UNDERSIGNED, AGREE THAT THE PRODUCT AS REPRESENTED SATISFIES DESIGN AND DIMENSION REQUIREMENTS. I ALSO ACKNOWLEDGE MY DUTY TO CONFIRM PRODUCT AND INSTALLATION COMPLIANCE WITH ALL APPLICABLE FEDERAL, STATE AND LOCAL REGULATIONS AND STANDARDS.

UNITS REQUIRING APPROVAL DRAWINGS OR MODIFIED ARE NON-RETURNABLE

[] As drawn [] As marked

Signed: _____ Date: _____

Printed Name: _____

LEAD TIME WILL START UPON RECEIPT OF SIGNED APPROVAL DRAWING

DISTRIBUTOR'S NAME:		P.O.#
VESTIL MANUFACTURING		X
DRAWN BY: NHD		W.O.#
DATE: 12/17/2007		X
REFERENCE: X	SCALE: 1:20	SALES: X
QUOTED LEAD TIME: X	QUOTE # X	FILE NAME:
		09-007-075