

# ERGONOMIC ATTACHMENT SKID FORKS - EA-SKSF-F4-1.50-36

APPROX WEIGHT: 376 lbs.  
 DOES NOT INCLUDE WEIGHT OF POWER OR PACKAGING!!!

\*\*\* ANY ADDITIONS, DELETIONS, OR OMISSIONS MUST BE CORRECTED ON THIS DRAWING AS THIS DRAWING WILL BE CONSIDERED ALL INCLUSIVE \*\*\*  
 ALL GRAPHICS PROVIDED ARE FOR REFERENCE ONLY. IF CERTAIN DIMENSIONS ARE CRITICAL PLEASE VERIFY THOSE DIMENSIONS WITH YOUR SALESPERSON

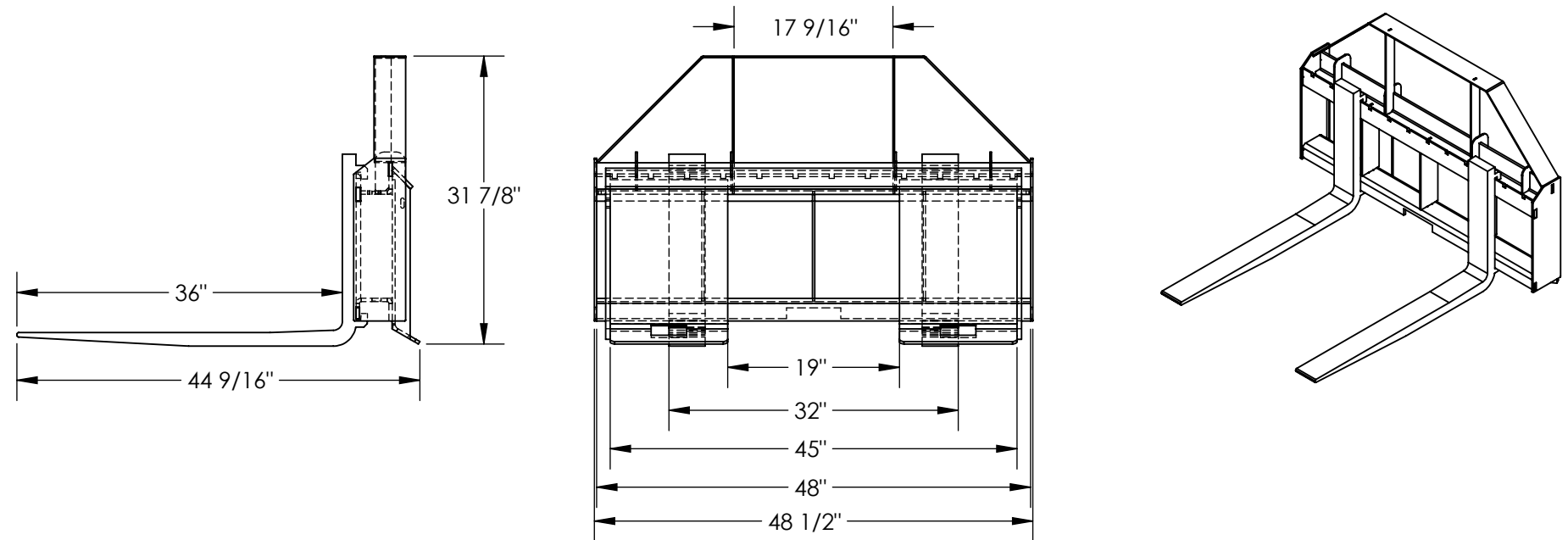

## STANDARD FEATURES

- MODEL NUMBER IS EA-SKSF-F4-1.50-36
- OVERALL WIDTH IS 48 1/2"
- USABLE WIDTH IS 48"
- OVERALL LENGTH IS 44 9/16"
- USABLE LENGTH IS 36"
- OVERALL HEIGHT IS 31 7/8"
- UNIVERSAL MOUNTING PLATE ON 32" CENTER
- MAX CAPACITY IS 4000 LBS
- TOUGH BAKED IN POWDER COAT BLACK FINISH

## SPECIAL FEATURES

NONE

DIMENSION TOLERANCE ± 1/4"

<b>A P P R O V A L</b>	I, THE UNDERSIGNED, AGREE THAT THE PRODUCT AS REPRESENTED SATISFIES DESIGN AND DIMENSION REQUIREMENTS. I ALSO ACKNOWLEDGE MY DUTY TO CONFIRM PRODUCT AND INSTALLATION COMPLIANCE WITH ALL APPLICABLE FEDERAL, STATE AND LOCAL REGULATIONS AND STANDARDS.	
	<b>UNITS REQUIRING APPROVAL DRAWINGS OR MODIFIED ARE NON-RETURNABLE</b>	
	[ ] As drawn      [ ] As marked	
	Signed: _____ Date: _____	
Printed Name: _____		
<i>LEAD TIME WILL START UPON RECEIPT OF SIGNED APPROVAL DRAWING</i>		

DISTRIBUTOR'S NAME:		P.O.#
<b>VESTIL MANUFACTURING</b>		X
		W.O.#
DRAWN BY: C.CLEMENS		X
DATE: 4/08/2021		SALES:
REFERENCE: X		X
QUOTED LEAD TIME: X		SCALE: 1:24
QUOTE #		FILE NAME:
X		50-007-049