

# ERGONOMIC ATTACHMENT SKID FORKS - EA-SKSF-F4-1.50-60

APPROX WEIGHT: 451 lbs.  
 DOES NOT INCLUDE WEIGHT OF POWER OR PACKAGING!!!

\*\*\* ANY ADDITIONS, DELETIONS, OR OMISSIONS MUST BE CORRECTED ON THIS DRAWING AS THIS DRAWING WILL BE CONSIDERED ALL INCLUSIVE \*\*\*

ALL GRAPHICS PROVIDED ARE FOR REFERENCE ONLY. IF CERTAIN DIMENSIONS ARE CRITICAL PLEASE VERIFY THOSE DIMENSIONS WITH YOUR SALESPERSON

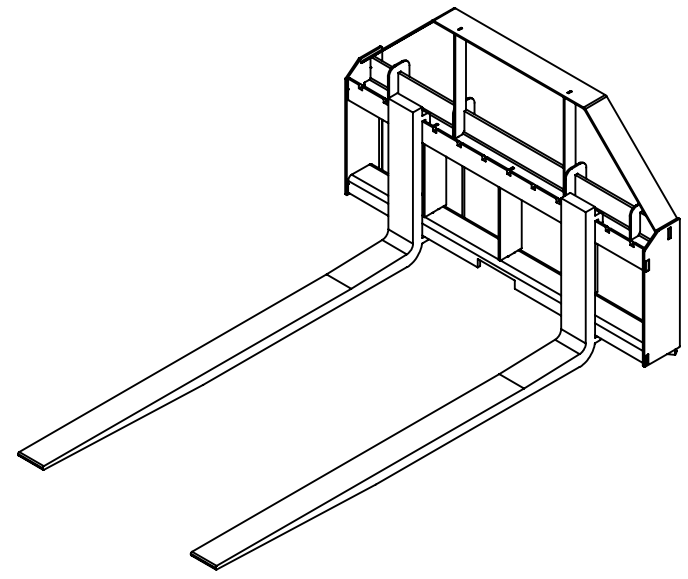
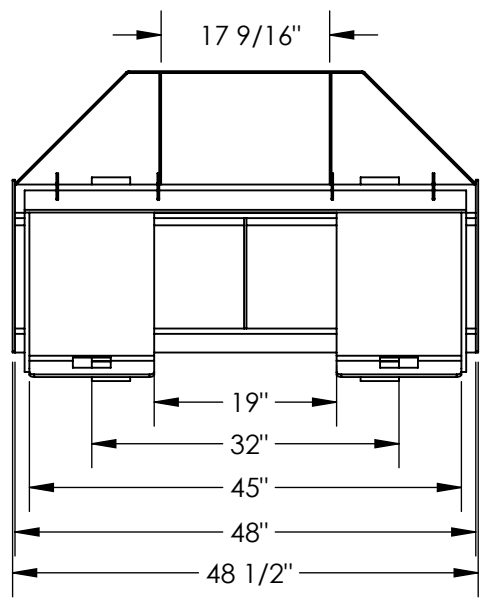
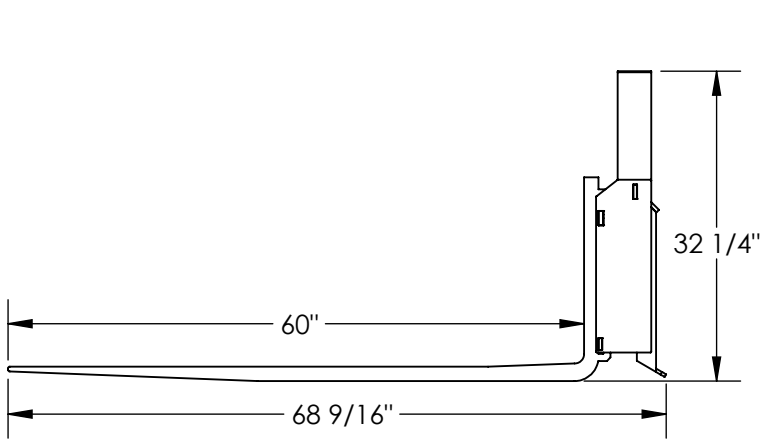

## STANDARD FEATURES

- MODEL NUMBER IS EA-SKSF-F4-1.50-60
- OVERALL WIDTH IS 48 1/2"
- USABLE WIDTH IS 48"
- OVERALL LENGTH IS 68 9/16"
- USABLE LENGTH IS 60"
- OVERALL HEIGHT IS 32 1/4"
- UNIVERSAL MOUNTING PLATE ON 32" CENTER
- MAX CAPACITY IS 4000 LBS
- TOUGH BAKED IN POWDER COAT BLACK FINISH

## SPECIAL FEATURES

NONE

DIMENSION TOLERANCE ± 1/4"

<b>APPROVAL</b>	I, THE UNDERSIGNED, AGREE THAT THE PRODUCT AS REPRESENTED SATISFIES DESIGN AND DIMENSION REQUIREMENTS. I ALSO ACKNOWLEDGE MY DUTY TO CONFIRM PRODUCT AND INSTALLATION COMPLIANCE WITH ALL APPLICABLE FEDERAL, STATE AND LOCAL REGULATIONS AND STANDARDS.	
	<b>UNITS REQUIRING APPROVAL DRAWINGS OR MODIFIED ARE NON-RETURNABLE</b>	
	[ ] As drawn      [ ] As marked	
Signed: _____		Date: _____
Printed Name: _____		
<i>LEAD TIME WILL START UPON RECEIPT OF SIGNED APPROVAL DRAWING</i>		

DISTRIBUTOR'S NAME:		P.O.#
VESTIL MANUFACTURING		X
DRAWN BY: C.CLEMENS		W.O.#
DATE: 4/08/2021		X
REFERENCE: X	SCALE: 1:12	SALES: X
QUOTED LEAD TIME: X	QUOTE #	FILE NAME:
	X	50-007-052