

# SCISSOR GROUND LIFT AND TILT - EHLTGT-5252-4-36

APPROX WEIGHT: 2172 lbs.  
DOES NOT INCLUDE WEIGHT OF POWER OR PACKAGING!!!

\*\*\* ANY ADDITIONS, DELETIONS, OR OMISSIONS MUST BE CORRECTED ON THIS DRAWING AS THIS DRAWING WILL BE CONSIDERED ALL INCLUSIVE \*\*\*  
ALL GRAPHICS PROVIDED ARE FOR REFERENCE ONLY. IF CERTAIN DIMENSIONS ARE CRITICAL PLEASE VERIFY THOSE DIMENSIONS WITH YOUR SALESPERSON

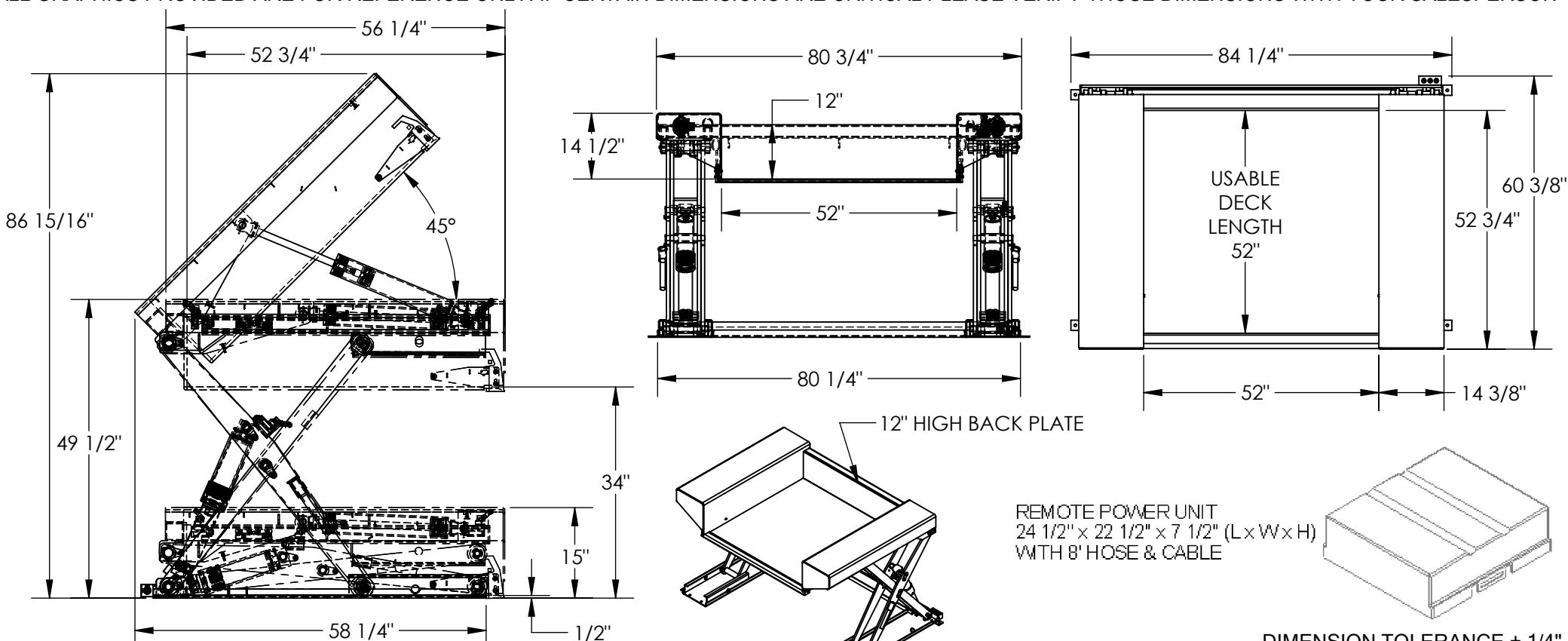

## STANDARD FEATURES

MODEL NUMBER IS EHLTGT-5252-4-36  
OVERALL WIDTH IS 84 1/4"  
USABLE WIDTH IS 52"  
OVERALL LENGTH IS 56 1/4"  
USABLE LENGTH IS 52"  
OVERALL HEIGHT IS 49 1/2"  
PLATFORM RAISED HEIGHT IS 34"  
PLATFORM LOWERED HEIGHT IS 1/2"  
MAX CAPACITY IS 4,000 LBS.  
DURABLE LIQUID PAINT BLUE FINISH  
CONTROL IS HANDHELD, 4 BUTTON, NEMA 4  
PENDANT WITH MINIMUM 8' USABLE COIL CORD  
EXTERNAL POWER UNIT

## PLEASE CIRCLE SPECIFICATIONS:

POWER	<input checked="" type="checkbox"/> AC	<input type="checkbox"/> DC (12V)	<input type="checkbox"/> AIR/OIL
MOTOR VOLTAGE	<input type="checkbox"/> 115	<input type="checkbox"/> 208	<input checked="" type="checkbox"/> 460
DEDICATED CIRCUIT REQUIRED 60Hz			
MOTOR PHASE	<input type="checkbox"/> SINGLE	<input checked="" type="checkbox"/> THREE	
CONTROL	<input type="checkbox"/> HAND	<input type="checkbox"/> FOOT	

**SPECIAL FEATURES**  
NONE

**APPROVAL**

I, THE UNDERSIGNED, AGREE THAT THE PRODUCT AS REPRESENTED SATISFIES DESIGN AND DIMENSION REQUIREMENTS. I ALSO ACKNOWLEDGE MY DUTY TO CONFIRM PRODUCT AND INSTALLATION COMPLIANCE WITH ALL APPLICABLE FEDERAL, STATE AND LOCAL REGULATIONS AND STANDARDS.  
**UNITS REQUIRING APPROVAL DRAWINGS OR MODIFIED ARE NON-RETURNABLE**  
[ ] As drawn [ ] As marked

Signed: \_\_\_\_\_ Date: \_\_\_\_\_  
Printed Name: \_\_\_\_\_  
**LEAD TIME WILL START UPON RECEIPT OF SIGNED APPROVAL DRAWING**

DISTRIBUTOR'S NAME: VESTIL MANUFACTURING

DRAWN BY: CRA DATE: 03/06/2023

REFERENCE: X SCALE: 1:32

QUOTED LEAD TIME: X QUOTE # X

P.O.# X  
W.O.# X  
SALES: X  
FILE NAME: 04-007-107