

LOW PROFILE SCISSOR TABLE - EHLTX-3656-1-39

APPROX WEIGHT: 713.73 lbs.
DOES NOT INCLUDE WEIGHT OF POWER OR PACKAGING!!!

*** ANY ADDITIONS, DELETIONS, OR OMISSIONS MUST BE CORRECTED ON THIS DRAWING AS THIS DRAWING WILL BE CONSIDERED ALL INCLUSIVE ***

ALL GRAPHICS PROVIDED ARE FOR REFERENCE ONLY. IF CERTAIN DIMENSIONS ARE CRITICAL PLEASE VERIFY THOSE DIMENSIONS WITH YOUR SALESPERSON

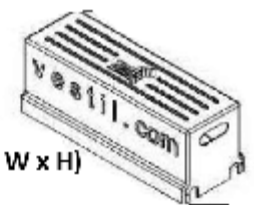
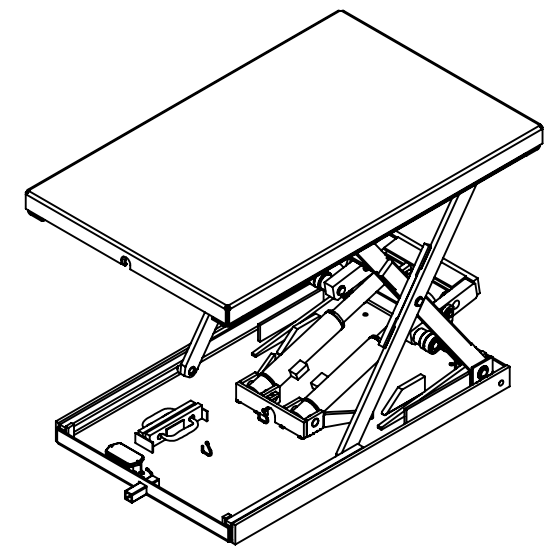
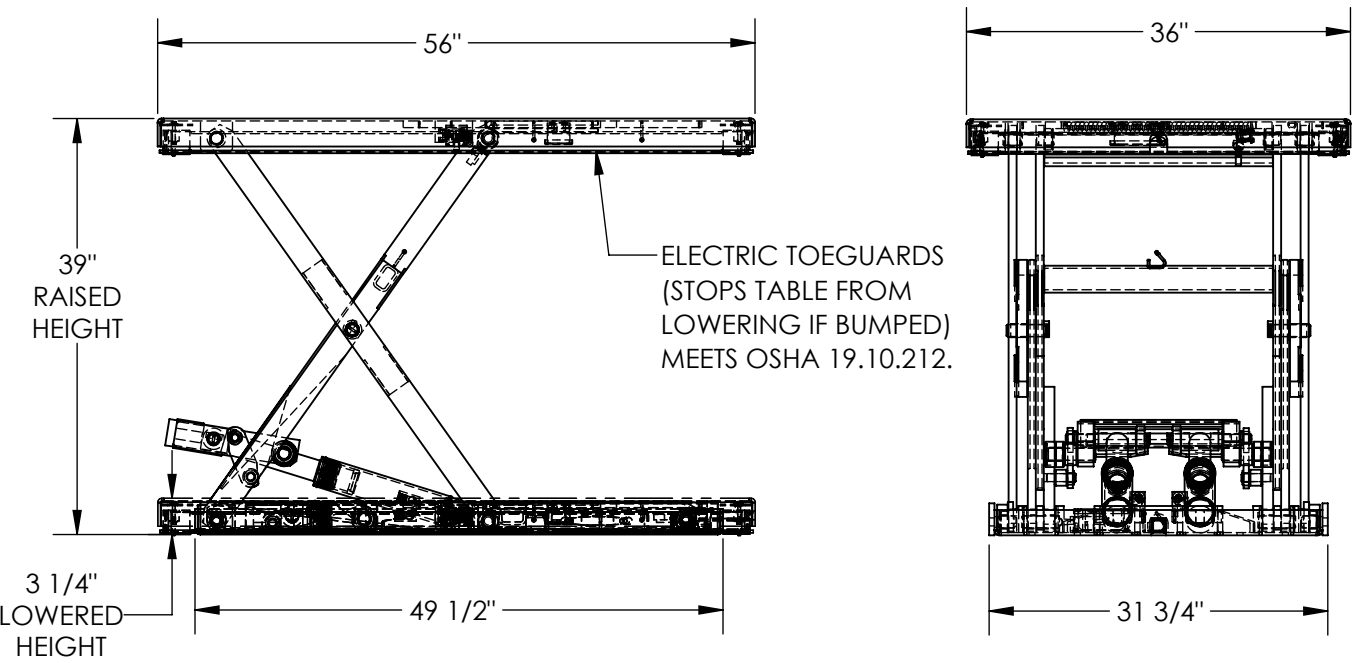

REMOTE POWER UNIT
32 1/2" x 12" x 12 1/2" (L x W x H)
WITH 8' HOSE & CABLE

DIMENSION TOLERANCE ± 1/4"

PLEASE CIRCLE SPECIFICATIONS:

| | | | |
|---------------------------------|-------------------|---------------------|--------------------|
| POWER | AC | DC (12V) | AIR/OIL |
| MOTOR VOLTAGE | 115 | 208 | 230 460 |
| DEDICATED CIRCUIT REQUIRED 60Hz | | | |
| MOTOR PHASE | SINGLE | THREE | |
| CONTROL | HAND | FOOT | |

DECK TOLERANCE ± 1/2"
TABLE HEIGHT TOLERANCE ± 1/2"
DECK FLATNESS ± 1/4"

NOTE:
* MOST DECK ADDITIONS DERATE THE TABLE BY AT LEAST 250 LBS

STANDARD FEATURES

- MODEL NUMBER IS EHLTX-3656-1-39
- PLATFORM WIDTH IS 36"
- PLATFORM LENGTH IS 56"
- BASE WIDTH IS 31 3/4"
- BASE LENGTH (WITHOUT ELECTRIC CORD TUBE) IS 49 1/2"
- UNIT LENGTH = PLATFORM LENGTH + 3/8"
- PLATFORM RAISED HEIGHT IS 39"
- PLATFORM LOWERED HEIGHT IS 3 1/4"
- MAX CAPACITY IS 1,000 LBS
- HAND CONTROL RAIN TIGHT ON 8' CORD
- DURABLE LIQUID PAINT BLUE FINISH

SPECIAL FEATURES

NONE

APPROVAL

I, THE UNDERSIGNED, AGREE THAT THE PRODUCT AS REPRESENTED SATISFIES DESIGN AND DIMENSION REQUIREMENTS. I ALSO ACKNOWLEDGE MY DUTY TO CONFIRM PRODUCT AND INSTALLATION COMPLIANCE WITH ALL APPLICABLE FEDERAL, STATE AND LOCAL REGULATIONS AND STANDARDS.

ANY MODIFIED UNITS ARE NON-RETURNABLE

[] As drawn [] As marked

Signed: _____ Date: _____

Printed Name: _____

LEAD TIME WILL START UPON RECEIPT OF SIGNED APPROVAL DRAWING

FOR INTERNAL USE ONLY
PROJECT SIGN OFF

| | |
|-------|--|
| SALES | |
| ENG. | |
| FAB. | |
| POWER | |

| | | |
|----------------------|------------------|----------------|
| DISTRIBUTOR'S NAME: | | P.O.# |
| VESTIL MANUFACTURING | | X |
| DRAWN BY: BCN | DATE: 10/25/2016 | W.O.# |
| REFERENCE: X | SCALE: 1:18 | X |
| QUOTED LEAD TIME: X | QUOTE # | FILE NAME: |
| | X | 27-007-101-001 |