

# EFFICIENCY MASTER TILT TABLE - EM1-500-6050-2

APPROX WEIGHT: 871.83 lbs.  
DOES NOT INCLUDE WEIGHT OF POWER OR PACKAGING!!!

\*\*\* ANY ADDITIONS, DELETIONS, OR OMISSIONS MUST BE CORRECTED ON THIS DRAWING AS THIS DRAWING WILL BE CONSIDERED ALL INCLUSIVE \*\*\*

ALL GRAPHICS PROVIDED ARE FOR REFERENCE ONLY. IF CERTAIN DIMENSIONS ARE CRITICAL PLEASE VERIFY THOSE DIMENSIONS WITH YOUR SALESPERSON

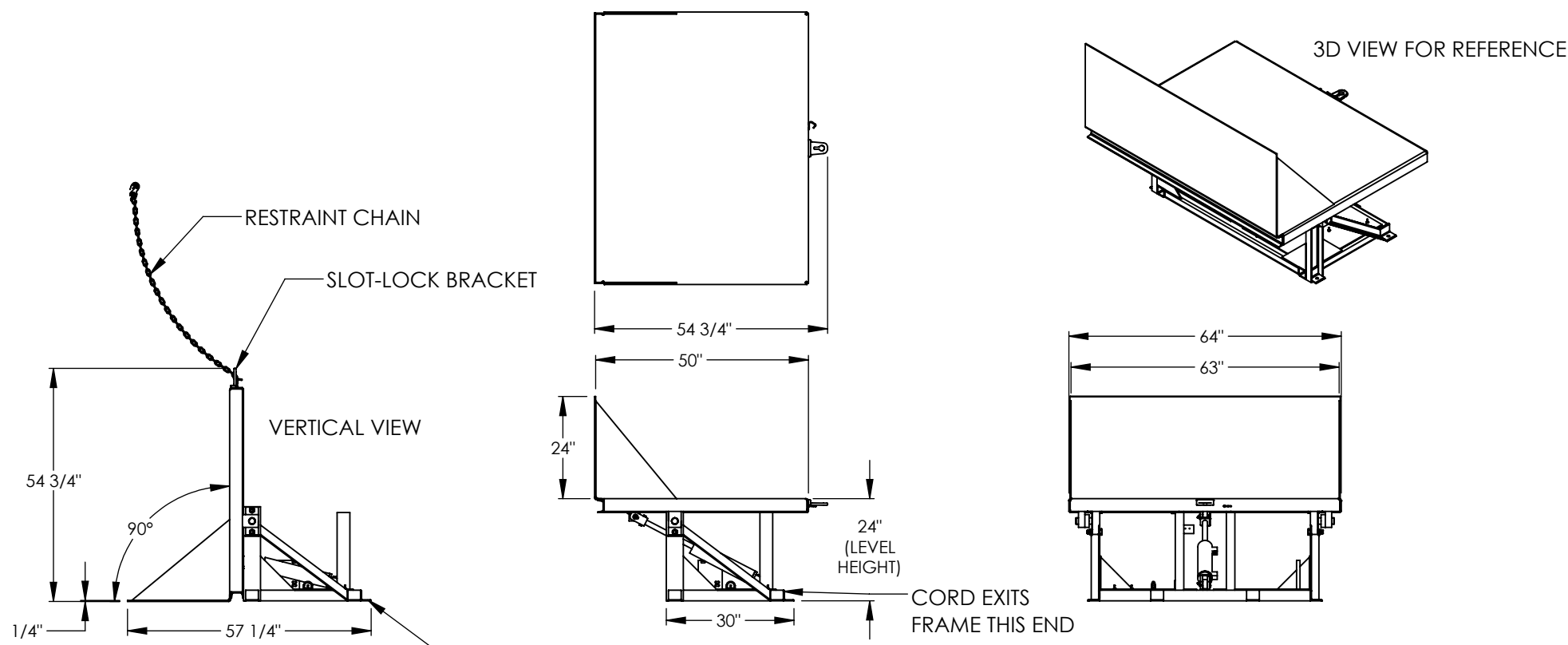

## STANDARD FEATURES

- MODEL NUMBER IS EM1-500-6050-2
- MAX CAPACITY IS 2,000 LBS (EVENLY DISTRIBUTED LOAD)
- OVERALL WIDTH IS 64"
- DECK LENGTH IS 50"
- OVERALL LENGTH IS 57 1/4"
- DECK LEVEL HEIGHT IS 24"
- OVERALL HEIGHT IS 54 3/4"
- MAX TILT ANGLE IS 90°
- SAFETY SLOT-LOCK RESTRAINT CHAIN BRACKET
- ALL STEEL CONSTRUCTION
- DURABLE LIQUID PAINT BLUE FINISH
- WARNING: CHECK STATE AND LOCAL CODES
- CONTROL IS HANDHELD, 2 BUTTON, NEMA 4 PENDANT WITH MINIMUM 8' USABLE COIL CORD
- INTERNAL POWER UNIT

## PLEASE CIRCLE SPECIFICATIONS:

POWER	<input checked="" type="checkbox"/> AC	<input type="checkbox"/> *DC	<input type="checkbox"/> AIR/OIL
MOTOR VOLTAGE	<input type="checkbox"/> 115	<input type="checkbox"/> 208	<input checked="" type="checkbox"/> 230 460
DEDICATED CIRCUIT REQUIRED			
MOTOR PHASE	<input type="checkbox"/> SINGLE	<input checked="" type="checkbox"/> THREE	
CONTROL	<input checked="" type="checkbox"/> HAND	<input type="checkbox"/> *FOOT	
~ ALL BATTERY CHARGERS ARE 115V AC ~			
* BATTERY CHR.G.	<input type="checkbox"/> REMOTE	<input type="checkbox"/> ON-BOARD	
* CHR.G. INDICATOR	<input type="checkbox"/> YES	<input type="checkbox"/> NO	

\* AVAILABLE AT ADDITIONAL COST

## SPECIAL FEATURES

NONE

DIMENSION TOLERANCE  $\pm$  1/4"

**APPROVAL**

I, THE UNDERSIGNED, AGREE THAT THE PRODUCT AS REPRESENTED SATISFIES DESIGN AND DIMENSION REQUIREMENTS. I ALSO ACKNOWLEDGE MY DUTY TO CONFIRM PRODUCT AND INSTALLATION COMPLIANCE WITH ALL APPLICABLE FEDERAL, STATE AND LOCAL REGULATIONS AND STANDARDS.

**UNITS REQUIRING APPROVAL DRAWINGS OR MODIFIED ARE NON-RETURNABLE**

[ ] As drawn [ ] As marked

Signed: \_\_\_\_\_ Date: \_\_\_\_\_

Printed Name: \_\_\_\_\_

LEAD TIME WILL START UPON RECEIPT OF SIGNED APPROVAL DRAWING

DISTRIBUTOR'S NAME:		P.O.#	
VESTIL MANUFACTURING		X	
DRAWN BY: MTS		DATE: 11/17/2015	W.O.#
REFERENCE: X		SCALE: 1:36	X
QUOTED LEAD TIME: X		QUOTE #	SALES: X
		X	FILE NAME:
			03-007-079