

EMHC-2860-2 (ELECTRIC MATERIAL HANDLING CART)

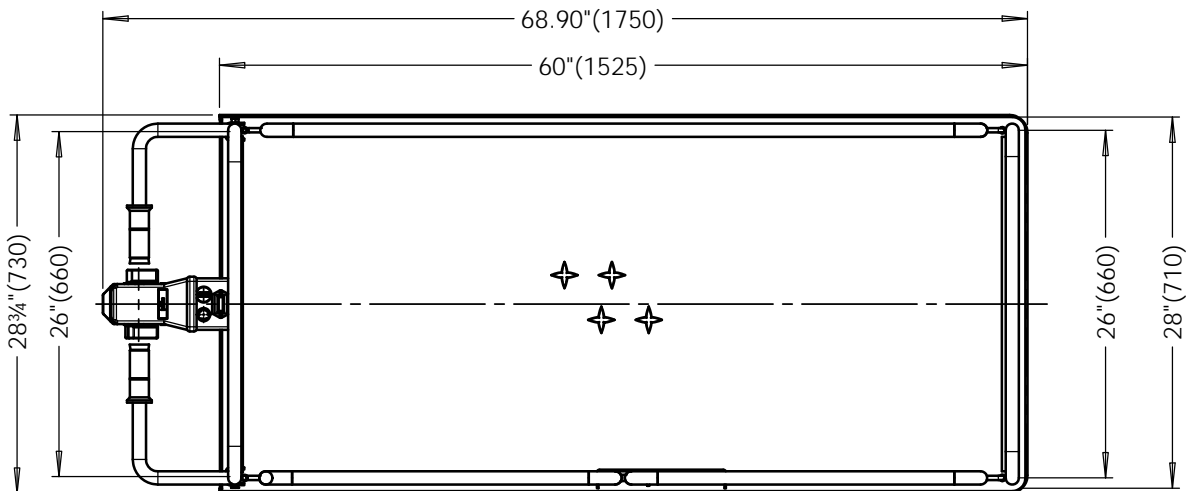
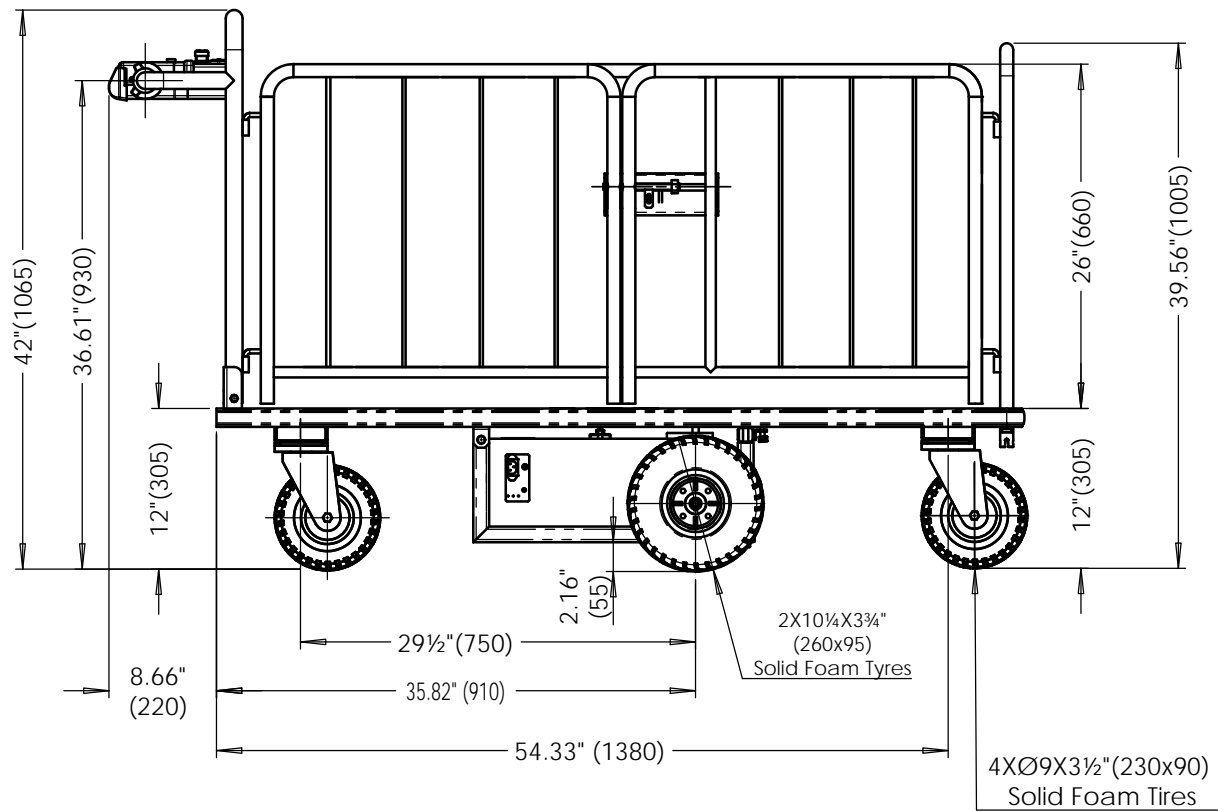

Specifications:

Capacity: 1,500 lbs (680 kgs.)
 Drive Axle: C04II-24/800
 Gear Ratio: 40:1
 Drive Motor: DC24V/800W
 Controller: Curtis 1228 - 2411
 Battery: 2x12V/45Ah (AGM)
 Charger: 24V/8Amps - (4amps/bank)
 Loaded Speed: 2.8m/h
 Unloaded Speed: 3.4m/h

Vestil Manufacturing Corp

Model:	EMHC-2860-2
Description: Electric Material Handling Cart	
Design: T.M.	Date: 08/07/2017