

15 GALLON FIBER DRUM: FD-15

APPROX WEIGHT: 20.44 lbs.
DOES NOT INCLUDE WEIGHT OF POWER OR PACKAGING!!!

*** ANY ADDITIONS, DELETIONS, OR OMISSIONS MUST BE CORRECTED ON THIS DRAWING AS THIS DRAWING WILL BE CONSIDERED ALL INCLUSIVE ***

ALL GRAPHICS PROVIDED ARE FOR REFERENCE ONLY. IF CERTAIN DIMENSIONS ARE CRITICAL PLEASE VERIFY THOSE DIMENSIONS WITH YOUR SALESPERSON

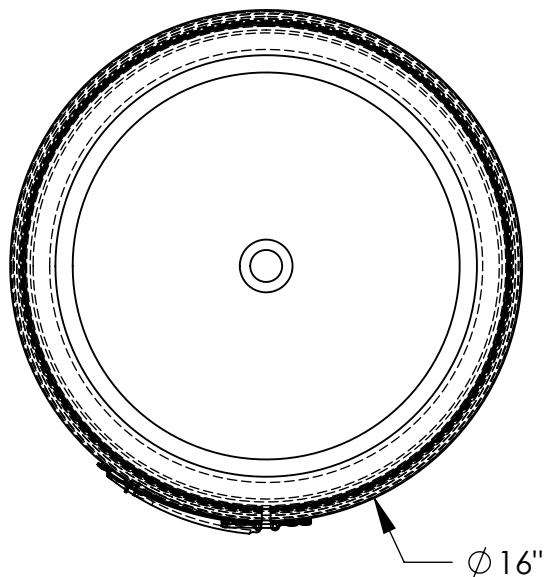

Ø 16"

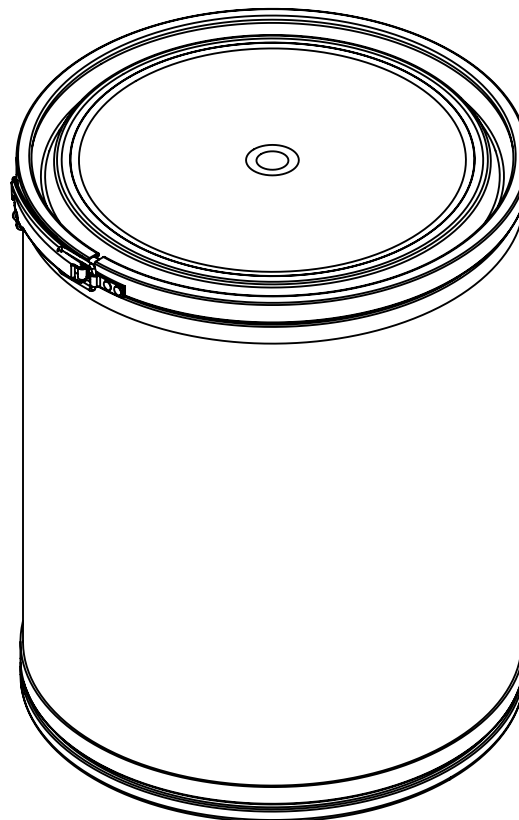

STANDARD FEATURES

MODEL NUMBER: FD-15
 DRUM CAPACITY: 15 GALLONS
 UNIFORM CAPACITY: 150 LBS.
 OVERALL DIAMETER: Ø16"
 INNER DIAMETER: Ø14 3/4"
 OVERALL HEIGHT: 20"
 STEEL CHIME REINFORCED
 TOP & BOTTOM
 LOCK RIM SIDE LEVER LOCK WITH
 STEEL LID

SPECIAL FEATURES

NONE

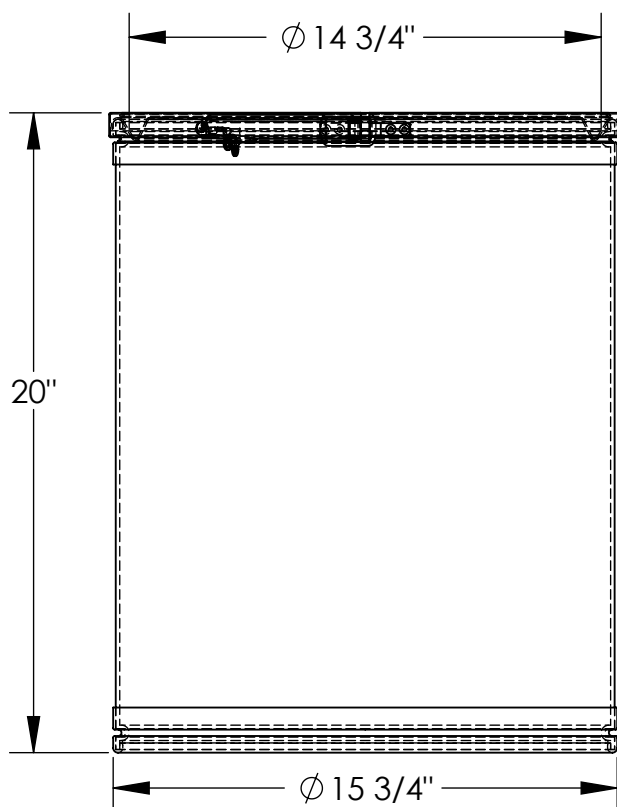

Ø 14 3/4"

20"

Ø 15 3/4"

DIMENSION TOLERANCE ± 1/4"

APPROVAL

I, THE UNDERSIGNED, AGREE THAT THE PRODUCT AS REPRESENTED SATISFIES DESIGN AND DIMENSION REQUIREMENTS. I ALSO ACKNOWLEDGE MY DUTY TO CONFIRM PRODUCT AND INSTALLATION COMPLIANCE WITH ALL APPLICABLE FEDERAL, STATE AND LOCAL REGULATIONS AND STANDARDS.
ALL SPECIAL UNITS ARE NON-RETURNABLE
 As drawn As marked

Signed: _____ Date: _____

LEAD TIME WILL START UPON RECEIPT OF SIGNED APPROVAL DRAWING

DISTRIBUTOR'S NAME:		P.O.#
VESTIL MANUFACTURING		X
DRAWN BY: TJM		W.O.#
DATE: 05/19/08		X
REFERENCE: X	SCALE: 1:6	SALES: X
QUOTED LEAD TIME: X	QUOTE #	FILE NAME:
	X	40-007-037