

# MECHANICAL EDGE-O-DOCKLEVELER - FM-2066

APPROX WEIGHT: 483.06 lbs.  
 DOES NOT INCLUDE WEIGHT OF POWER OR PACKAGING!!!

\*\*\* ANY ADDITIONS, DELETIONS, OR OMISSIONS MUST BE CORRECTED ON THIS DRAWING AS THIS DRAWING WILL BE CONSIDERED ALL INCLUSIVE \*\*\*

ALL GRAPHICS PROVIDED ARE FOR REFERENCE ONLY. IF CERTAIN DIMENSIONS ARE CRITICAL PLEASE VERIFY THOSE DIMENSIONS WITH YOUR SALESPERSON

NOTE: HANDLE NOT SHOWN IN THIS VIEW.

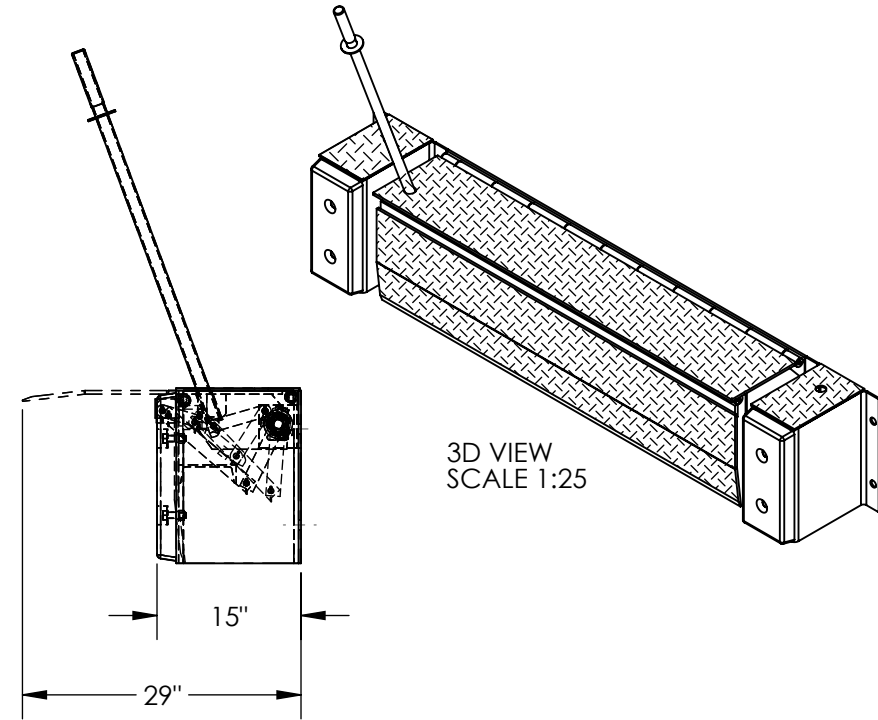
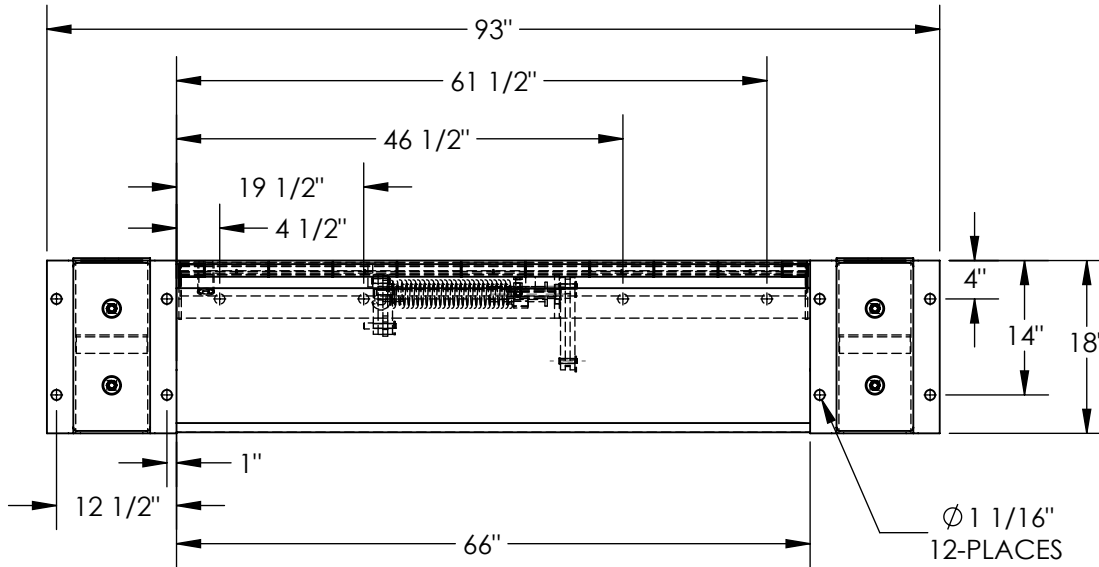

3D VIEW  
SCALE 1:25

DIMENSION TOLERANCE  $\pm 1/4$ "

## STANDARD FEATURES

- MODEL NUMBER IS FM-2066
- DECK WIDTH IS 66"
- OVERALL WIDTH IS 93"
- MAX CAPACITY IS 20,000 LBS
- STANDARD TOE GUARDS
- GREASE ZERK FITTINGS
- 18" HIGH BUMPERS (TO SERVE LOW TRUCKS)
- ADJUSTABLE TORSION SPRING COUNTERBALANCE MECHANISM
- SERVICE RANGE OF 5" ABOVE AND BELOW DOCK
- UNIT COMES COMPLETE WITH BUMPERS AND HANDLE
- TREADPLATE RAMP & DECK CONSTRUCTION

EDGE-O-DOCKS & DOCK SEALS OR SHELTERS CAN BE USED TOGETHER.  
 DOCK SEALS OR SHELTERS REQUIRE A 20" MINIMUM PROJECTION

## SPECIAL FEATURES

NONE

|   |  |  |
|---|--|--|
| <b>APPROVAL</b>   | I, THE UNDERSIGNED, AGREE THAT THE PRODUCT AS REPRESENTED SATISFIES DESIGN AND DIMENSION REQUIREMENTS. I ALSO ACKNOWLEDGE MY DUTY TO CONFIRM PRODUCT AND INSTALLATION COMPLIANCE WITH ALL APPLICABLE FEDERAL, STATE AND LOCAL REGULATIONS AND STANDARDS. |  |
|   | <b>ANY MODIFIED UNITS ARE NON-RETURNABLE</b>   |  |
|   | [ ] As drawn      [ ] As marked  |  |
|   | Signed: _____ Date: _____  |  |
| Printed Name: _____   |  |  |
| <b>LEAD TIME WILL START UPON RECEIPT OF SIGNED APPROVAL DRAWING</b> |  |  |

|   |  |
|---|--|
| FOR INTERNAL USE ONLY<br>PROJECT SIGN OFF |  |
| SALES                                     |  |
| ENG.                                      |  |
| FAB.                                      |  |
| POWER                                     |  |

|                      |                  |            |
|----------------------|------------------|------------|
| DISTRIBUTOR'S NAME:  |                  | P.O.#      |
| VESTIL MANUFACTURING |                  | X          |
| W.O.#                |                  | X          |
| DRAWN BY: MW         | DATE: 01/02/2013 | SALES: X   |
| REFERENCE: X         | SCALE: 1:20      | FILE NAME: |
| QUOTED LEAD TIME: X  | QUOTE # X        | 07-007-003 |