

# ECONOMICAL PORTABLE LOADING PLATFORM W/HANDRAIL OPTION -FTLP-5454-HR

APPROX WEIGHT: 430.90 lbs.  
 DOES NOT INCLUDE WEIGHT OF POWER OR PACKAGING!!!

\*\*\* ANY ADDITIONS, DELETIONS, OR OMISSIONS MUST BE CORRECTED ON THIS DRAWING AS THIS DRAWING WILL BE CONSIDERED ALL INCLUSIVE \*\*\*  
 ALL GRAPHICS PROVIDED ARE FOR REFERENCE ONLY. IF CERTAIN DIMENSIONS ARE CRITICAL PLEASE VERIFY THOSE DIMENSIONS WITH YOUR SALESPERSON

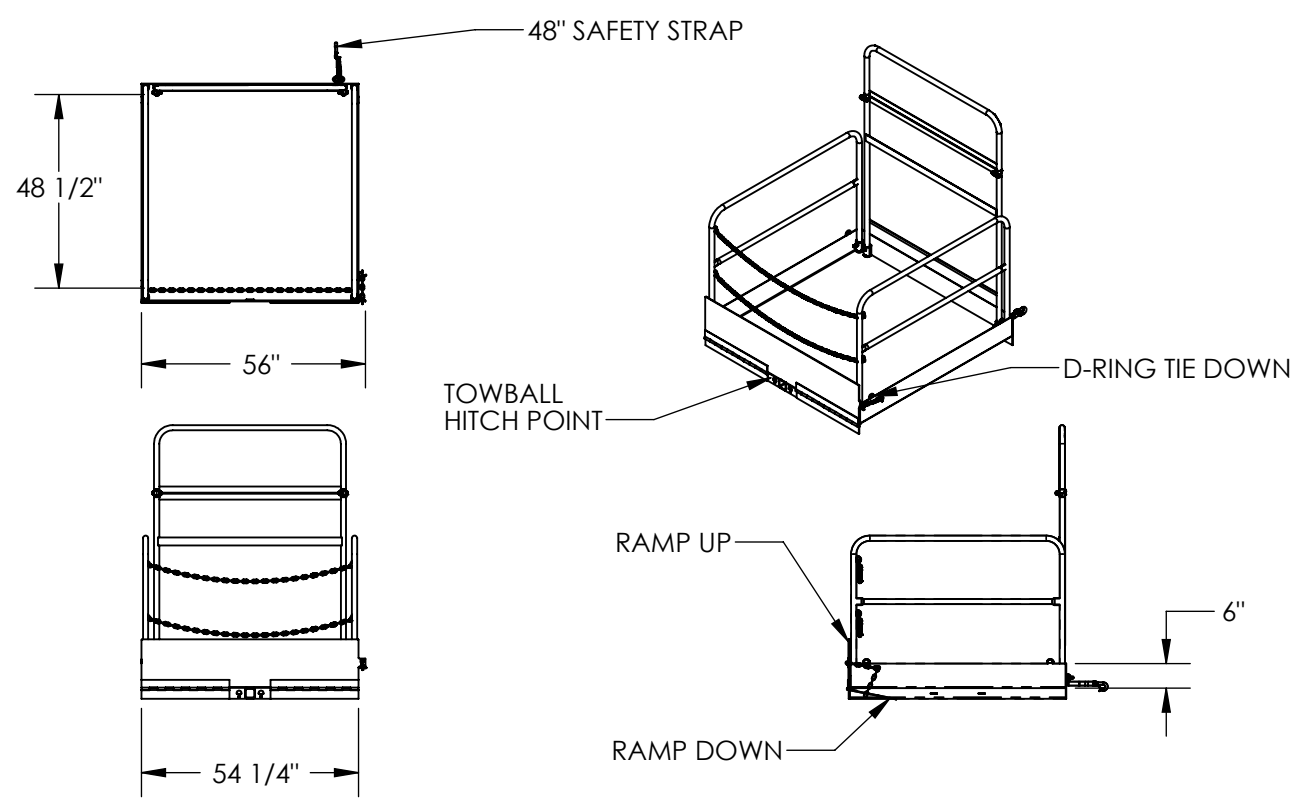

APPROX. WEIGHT / LOST LOAD = 430.90  
 MINIMUM EFFECTIVE THICKNESS = LESS THAN 1"  
 NEVER EXCEED LOAD CENTER  
 RATING PER FORKTRUCK  
 MANUFACTURERS GUIDELINES.  
 DO NOT USE THIS FORK TRUCK  
 ATTACHMENT IF LOAD WILL  
 EXCEED FORK TRUCK MANUFACTURER'S  
 LOAD CENTER RATING

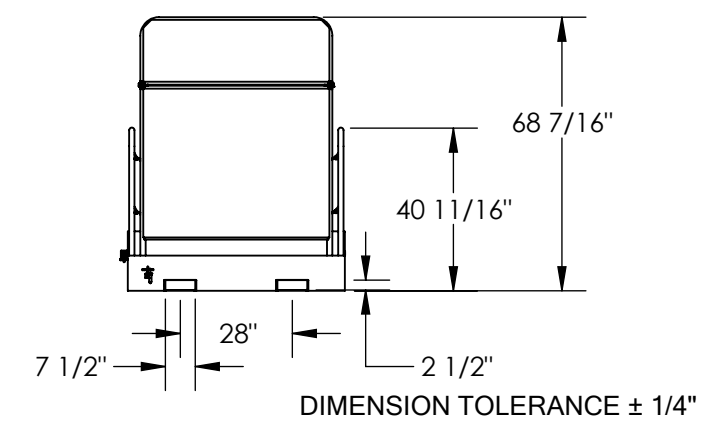

## STANDARD FEATURES

- MODEL NUMBER IS: FTLP-5454-HR
- USABLE WIDTH IS: 56"
- USABLE LENGTH IS: 48 1/2"
- OVERALL HEIGHT IS: 68 7/16"
- SIDE GUARD HEIGHT IS: 6"
- MAX CAPACITY IS 2,000 LBS WITH TA UNIFORM LOAD  
 (DEPENDENT ON FORK TRUCK CAPACITY)
- FORK POCKETS ARE 7-1/2" WIDE X 2-1/2" HIGH USABLE  
 (WITH 28" CENTERS)
- 4 TIE DOWN RINGS INCLUDED - LOCATED ON CORNERS
- 48" SAFETY STRAP TO SECURE PLATFORM TO FORK TRUCK (INCLUDED)
- BASE IS TOUGH BAKED IT POWDER COAT BLUE FINISH
- HANDRAILS ARE TOUGH BAKED IT POWDER COAT YELLOW FINISH

## SPECIAL FEATURES

NONE

**APPROVAL**

I, THE UNDERSIGNED, AGREE THAT THE PRODUCT AS REPRESENTED SATISFIES DESIGN AND DIMENSION REQUIREMENTS. I ALSO ACKNOWLEDGE MY DUTY TO CONFIRM PRODUCT AND INSTALLATION COMPLIANCE WITH ALL APPLICABLE FEDERAL, STATE AND LOCAL REGULATIONS AND STANDARDS.

**UNITS REQUIRING APPROVAL DRAWINGS OR MODIFIED ARE NON-RETURNABLE**

As drawn       As marked

Signed: \_\_\_\_\_ Date: \_\_\_\_\_

Printed Name: \_\_\_\_\_

*LEAD TIME WILL START UPON RECEIPT OF SIGNED APPROVAL DRAWING*

DISTRIBUTOR'S NAME:		P.O.#
VESTIL MANUFACTURING		X
DRAWN BY: BCN		W.O.#
DATE: 1/14/2016		X
REFERENCE: X	SCALE: 1:48	SALES: X
QUOTED LEAD TIME: X	QUOTE #	FILE NAME:
	X	14-007-098