

ECONOMY CHAIN HOIST WITH CHAIN CONTAINER - H-1000-3

APPROX WEIGHT: 84.00 lbs.

DOES NOT INCLUDE WEIGHT OF POWER OR PACKAGING!!!

ANY ADDITIONS, DELETIONS, OR OMISSIONS MUST BE CORRECTED ON THIS DRAWING AS THIS DRAWING WILL BE CONSIDERED ALL INCLUSIVE

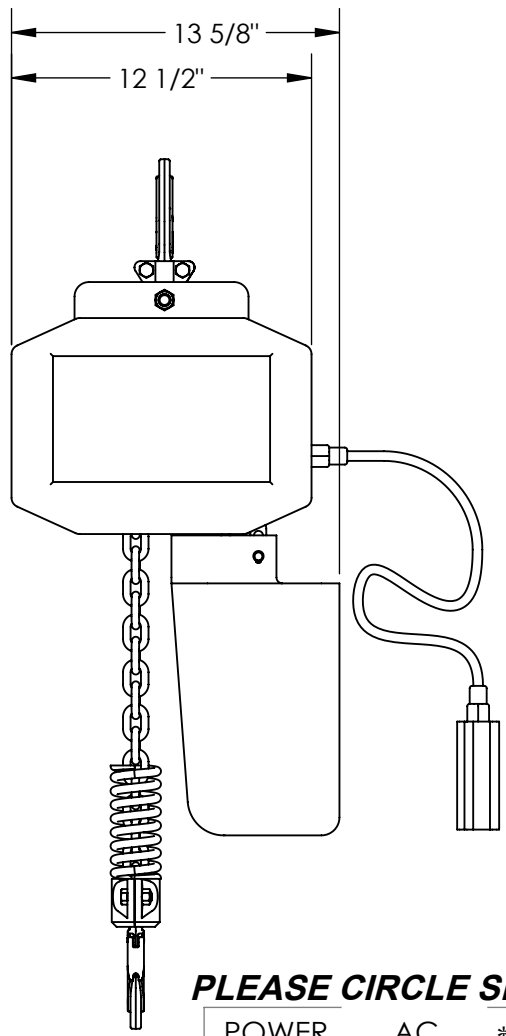
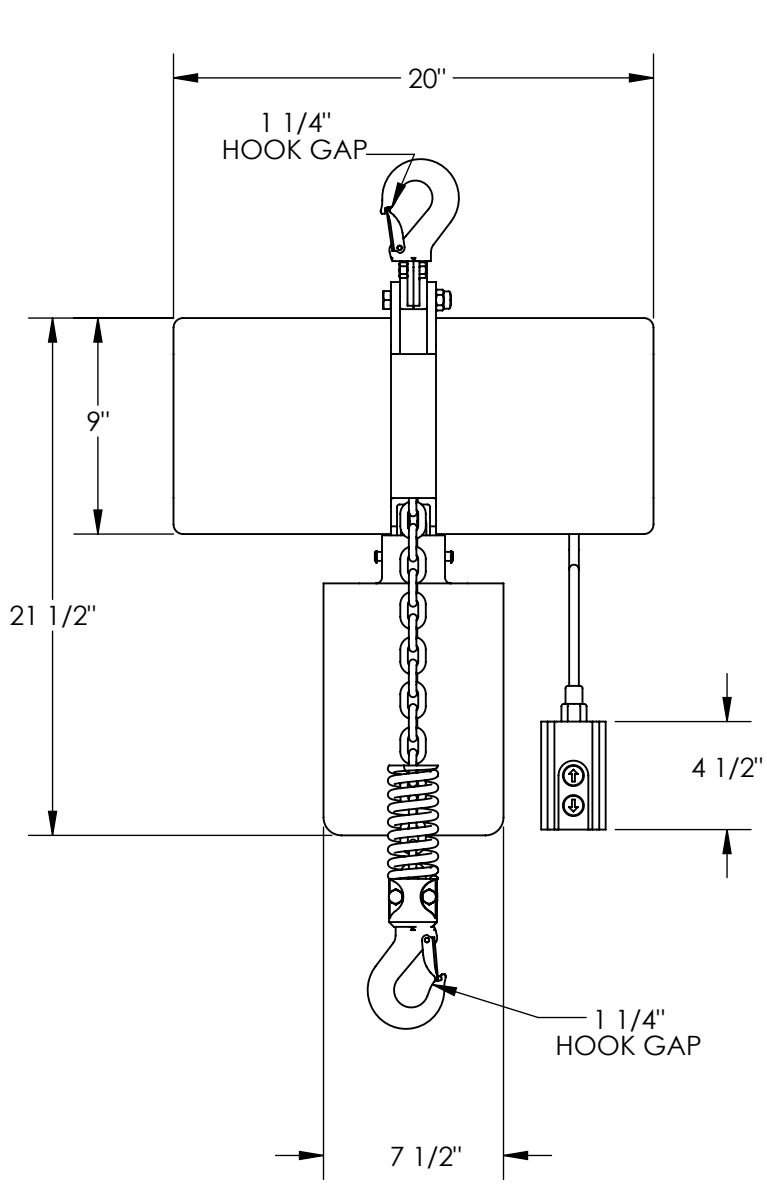

DIMENSION TOLERANCE ± 1/4"

PLEASE CIRCLE SPECIFICATIONS:

POWER	AC	* DC	* AIR/OIL
MOTOR VOLTAGE	115	208	230 460
DEDICATED CIRCUIT REQUIRED			
MOTOR PHASE	SINGLE	THREE	
CONTROL	HAND	* FOOT	
~ ALL BATTERY CHARGERS ARE 115V AC ~			
* BATTERY CHRG.	REMOTE	ON-BOARD	
* CHRG. INDICATOR	YES	NO	

* AVAILABLE AT ADDITIONAL COST

ALL GRAPHICS PROVIDED ARE FOR REFERENCE ONLY. IF CERTAIN DIMENSIONS ARE CRITICAL PLEASE VERIFY THOSE DIMENSIONS WITH YOUR SALESPERSON

STANDARD FEATURES

- MODEL NUMBER IS H-1000-3
- CAPACITY IS 1,000 LBS
- OVERALL WIDTH IS 12 1/2"
- OVERALL LENGTH IS 20"
- OVERALL HEIGHT IS 21 9/16"
- HEAD ROOM IS 21 7/16"
- FEET PER MINUTE IS 20 1/2'
- CHAIN LIFT LENGTH IS 15'
- REMOTE CORD LENGTH IS 15'

SPECIAL FEATURES

NONE

APPROVAL

I, THE UNDERSIGNED, AGREE THAT THE PRODUCT AS REPRESENTED SATISFIES DESIGN AND DIMENSION REQUIREMENTS. I ALSO ACKNOWLEDGE MY DUTY TO CONFIRM PRODUCT AND INSTALLATION COMPLIANCE WITH ALL APPLICABLE FEDERAL, STATE AND LOCAL REGULATIONS AND STANDARDS.

ALL SPECIAL UNITS ARE NON-RETURNABLE

[] As drawn [] As marked

Signed: _____ Date: _____

LEAD TIME WILL START UPON RECEIPT OF SIGNED APPROVAL DRAWING

DISTRIBUTOR'S NAME:		P.O.#
VESTIL MANUFACTURING		X
DRAWN BY: WHR		W.O.#
DATE: 6/21/12		X
REFERENCE: X	SCALE: 1:8	SALES: X
QUOTED LEAD TIME: X	QUOTE # X	FILE NAME:
		28-007-280