

HYDRAULIC BOX DUMPER - HBD-4-60

APPROX WEIGHT: 2012.51 lbs.
DOES NOT INCLUDE WEIGHT OF POWER OR PACKAGING!!!

*** ANY ADDITIONS, DELETIONS, OR OMISSIONS MUST BE CORRECTED ON THIS DRAWING AS THIS DRAWING WILL BE CONSIDERED ALL INCLUSIVE ***

ALL GRAPHICS PROVIDED ARE FOR REFERENCE ONLY. IF CERTAIN DIMENSIONS ARE CRITICAL PLEASE VERIFY THOSE DIMENSIONS WITH YOUR SALESPERSON

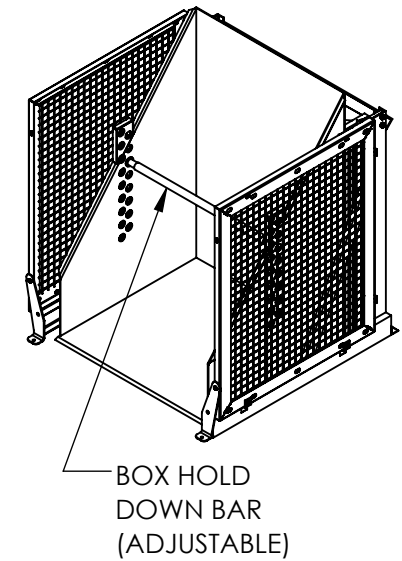
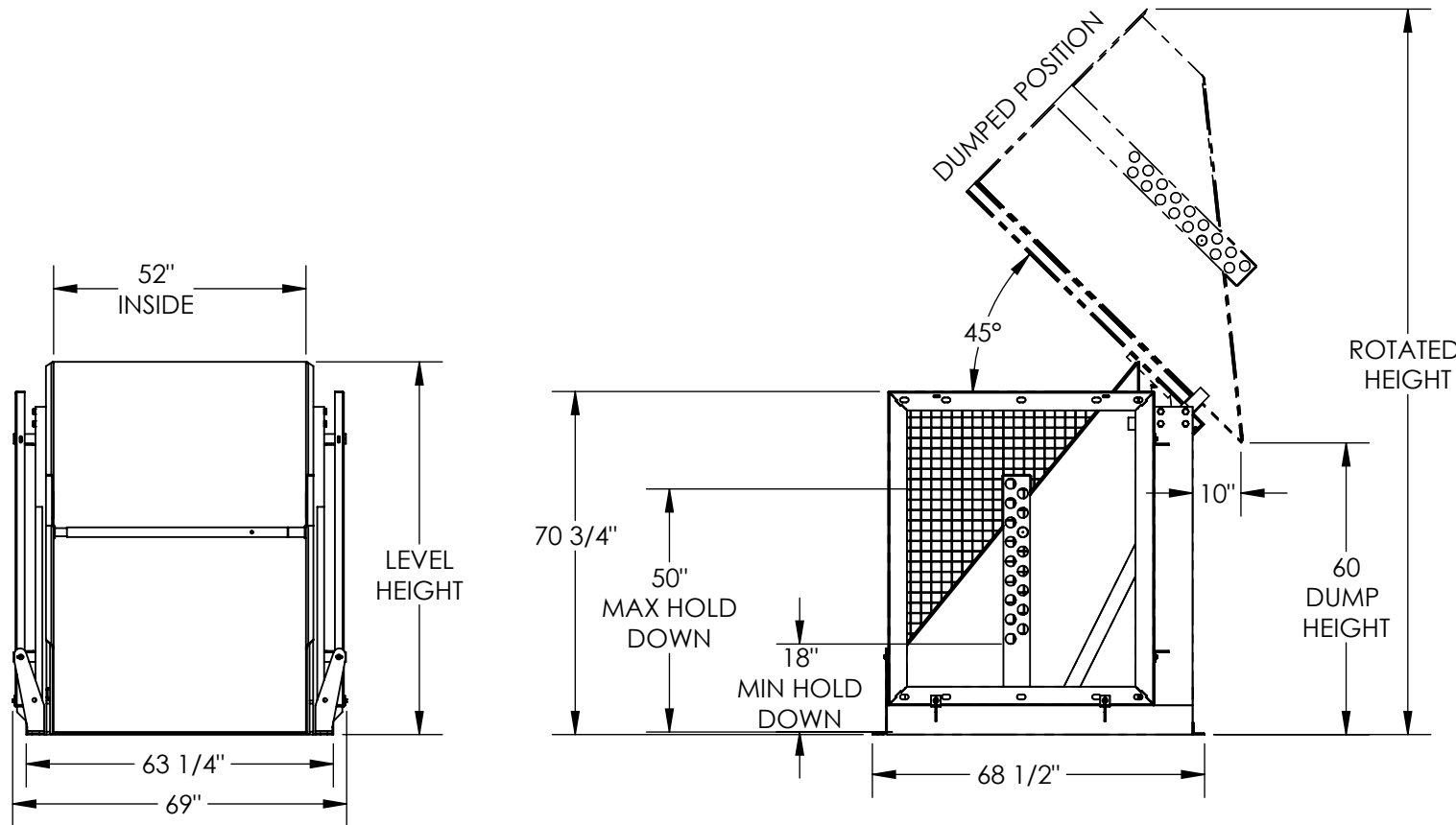

**460V 3 PHASE
AC POWER**

CONTACT FACTORY FOR
OTHER POWER OPTIONS

NOTE: SINGLE PH. PLUG-IN UNITS WILL HAVE
APPROX 120 SEC DUMP / 33 SEC LOWER

STANDARD FEATURES

- HYDRAULIC BOX DUMPER MODEL IS HBD-4-60
- CHUTE IS 52" W X 50" L (USABLE)
- DUMPER CAPACITY IS 4000 LBS.
- DUMP HEIGHT IS 60"
- HOLD DOWN WILL ACCEPT BOXES 18" TO 50" HIGH W/ HOLES EVERY 2"
- FRAME WIDTH IS 69"
- FRAME LENGTH IS 68 1/2"
- LEVEL HEIGHT IS 77"
- ROTATED HEIGHT IS 149 1/2"
- DUMP ANGLE IS 45°
- CHROME PLATED CYLINDER WITH EMERGENCY STOP VELOCITY FUSE
- WARNING: CHECK STATE AND LOCAL CODES!!
- HANDHELD PUSH BUTTON CONTROL W/ 8ft EXTENDED COIL CORD
- FRAME & CHUTE DURABLE LIQUID PAINT BLUE FINISH
- GUARDS & HOLD DOWN BAR DURABLE BAKED IN POWDER COATED YELLOW FINISH

SPECIAL FEATURES

NONE

APPROVAL	I, THE UNDERSIGNED, AGREE THAT THE PRODUCT AS REPRESENTED SATISFIES DESIGN AND DIMENSION REQUIREMENTS. I ALSO ACKNOWLEDGE MY DUTY TO CONFIRM PRODUCT AND INSTALLATION COMPLIANCE WITH ALL APPLICABLE FEDERAL, STATE AND LOCAL REGULATIONS AND STANDARDS.	
	UNITS REQUIRING APPROVAL DRAWINGS OR MODIFIED ARE NON-RETURNABLE	
	<input type="checkbox"/> As drawn	<input type="checkbox"/> As marked
Signed:	Date: _____	
Printed Name:	_____	
LEAD TIME WILL START UPON RECEIPT OF SIGNED APPROVAL DRAWING		

DISTRIBUTOR'S NAME:		P.O.#
VESTIL MANUFACTURING		X
DRAWN BY: SJA		DATE: 2/4/2015
REFERENCE: X		SCALE: 1:38
QUOTED LEAD TIME: X		QUOTE # X
		SALES: X
		FILE NAME: 34-007-038

DIMENSION TOLERANCE ± 1/4"