

HBD LIGHT CURTAIN OPTION - HBD-SLC

APPROX WEIGHT: 437.78 lbs.
DOES NOT INCLUDE WEIGHT OF POWER OR PACKAGING!!!

*** ANY ADDITIONS, DELETIONS, OR OMISSIONS MUST BE CORRECTED ON THIS DRAWING AS THIS DRAWING WILL BE CONSIDERED ALL INCLUSIVE ***

ALL GRAPHICS PROVIDED ARE FOR REFERENCE ONLY. IF CERTAIN DIMENSIONS ARE CRITICAL PLEASE VERIFY THOSE DIMENSIONS WITH YOUR SALESPERSON

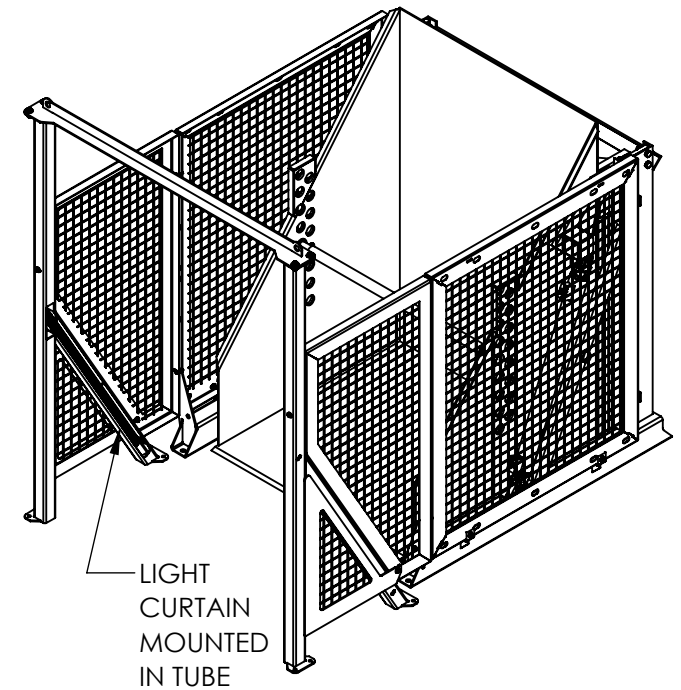
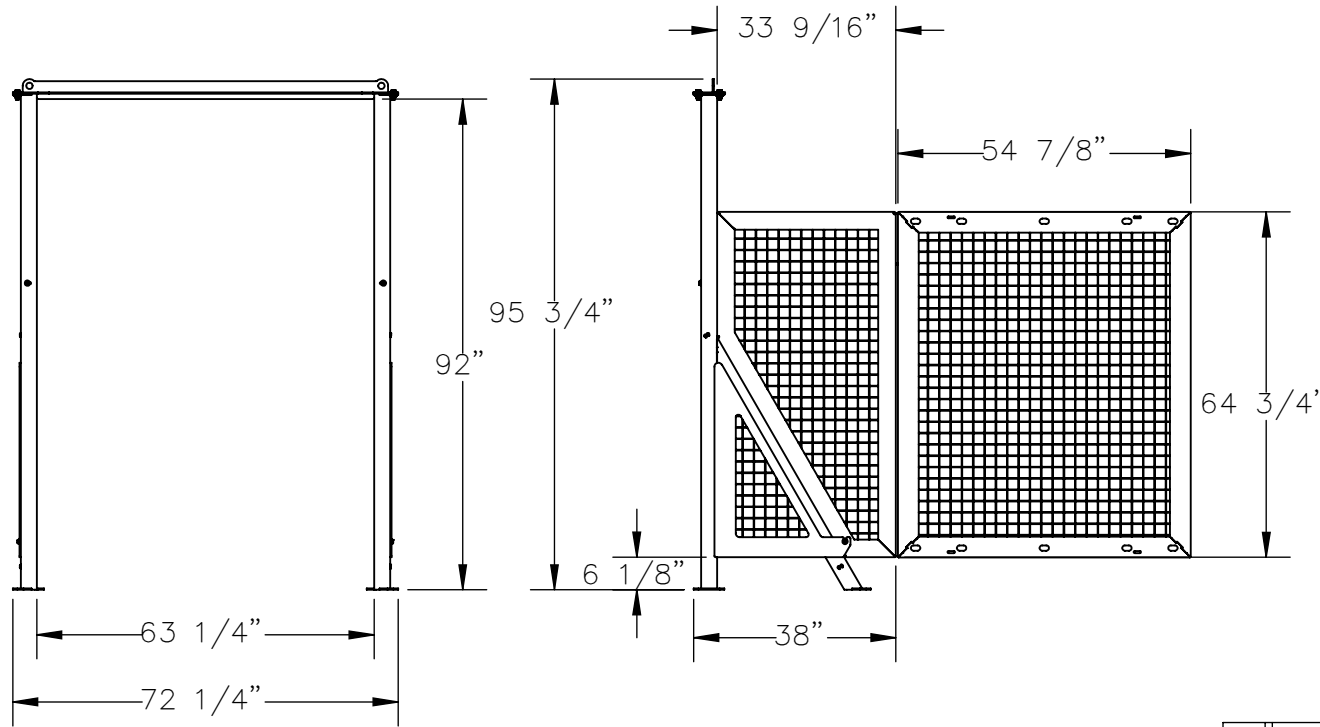

DIMENSION TOLERANCE ± 1/4"

STANDARD FEATURES

- MODEL NUMBER IS HBD-SLC
- HBD LIGHT CURTAIN OPTION BOLTS TO STANDARD HBD DUMPER WILL NOT OPERATE WHEN CURTAIN IS INTERUPED
- STANDARD CONTINUOUS PUSH BUTTON RAISE AND LOWER
- AUTOMATED CYCLES AVAILABLE - CONTACT FACTORY FOR QUOTE
- OVERALL WIDTH IS 72 1/4"
- USABLE WIDTH IS 63 1/4"
- OVERALL HEIGHT IS 95 3/4"
- USABLE HEIGHT IS 92" UNDER HEADER
- GUARD AND ENTRANCE DURABLE POWDER COAT YELLOW FINISH

SPECIAL FEATURES

NONE

APPROVAL

I, THE UNDERSIGNED, AGREE THAT THE PRODUCT AS REPRESENTED SATISFIES DESIGN AND DIMENSION REQUIREMENTS. I ALSO ACKNOWLEDGE MY DUTY TO CONFIRM PRODUCT AND INSTALLATION COMPLIANCE WITH ALL APPLICABLE FEDERAL, STATE AND LOCAL REGULATIONS AND STANDARDS.

UNITS REQUIRING APPROVAL DRAWINGS OR MODIFIED ARE NON-RETURNABLE

[] As drawn [] As marked

Signed: _____ Date: _____

Printed Name: _____

LEAD TIME WILL START UPON RECEIPT OF SIGNED APPROVAL DRAWING

DISTRIBUTOR'S NAME:		P.O.#
VESTIL MANUFACTURING		X
DRAWN BY: TEN		DATE: 07/03/2024
REFERENCE: X		SALES: X
QUOTED LEAD TIME: X		SCALE: 1:36
QUOTE # X		FILE NAME: 34-007-049