

STATIONARY HYDRAULIC DRUM DUMPER- HDD-48-10-P APPROX WEIGHT: 759.23 lbs.
 DOES NOT INCLUDE WEIGHT OF POWER OR PACKAGING!!!

ANY ADDITIONS, DELETIONS, OR OMISSIONS MUST BE CORRECTED ON THIS DRAWING AS THIS DRAWING WILL BE CONSIDERED ALL INCLUSIVE

ALL GRAPHICS PROVIDED ARE FOR REFERENCE ONLY. IF CERTAIN DIMENSIONS ARE CRITICAL PLEASE VERIFY THOSE DIMENSIONS WITH YOUR SALESPERSON

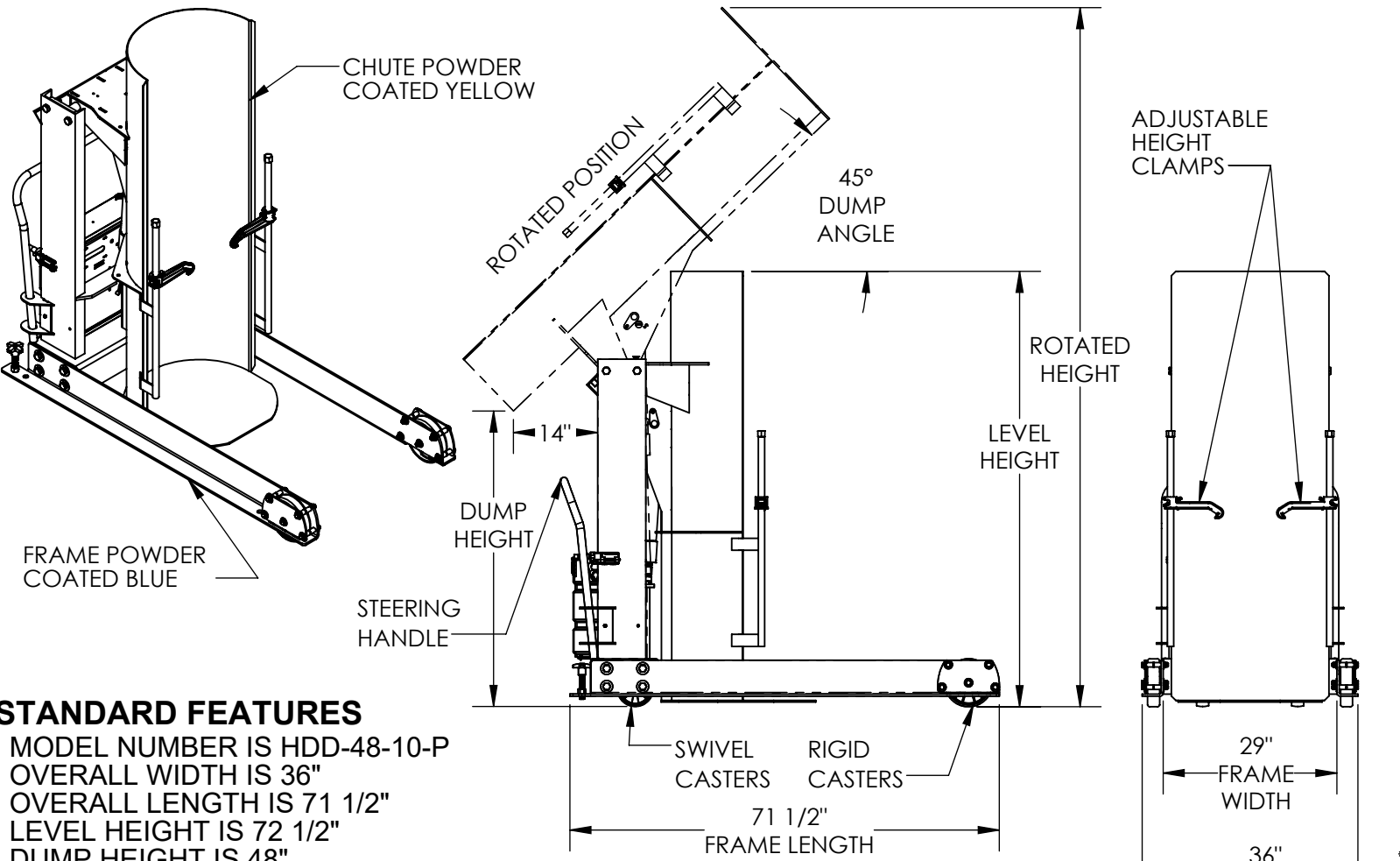

STANDARD FEATURES

- MODEL NUMBER IS HDD-48-10-P
- OVERALL WIDTH IS 36"
- OVERALL LENGTH IS 71 1/2"
- LEVEL HEIGHT IS 72 1/2"
- DUMP HEIGHT IS 48"
- ROTATION HEIGHT CLEARANCE IS 116 3/4"
- DUMP ANGLE IS 45°
- MAX CAPACITY IS 1000 LBS,
- ALL STEEL CONSTRUCTION
- PENDANT HAND CONTROL WITH 8' CORD
- ACCEPTS DRUM SIZE:
 Ø 16 1/2" TO Ø23 1/2" (ROUND) X 27 1/2" TO 39 1/2" H (TALL)
- INCLUDES: (2) SWIVEL CASTERS, (2) RIGID CASTERS, (1) STEERING HANDLE
- TOUGH BAKED IN POWDER COATED FINISH
- BASE POWDER COATED BLUE
- CHUTE POWDER COATED YELLOW

SPECIAL FEATURES
 NONE

DIMENSION TOLERANCE ± 1/4"

3,000 P.S.I. HYDRAULIC COMPONENTS RATING
WARNING: CHECK STATE AND LOCAL CODES !!!

PLEASE CIRCLE SPECIFICATIONS:

POWER	<input checked="" type="checkbox"/> AC	<input type="checkbox"/> *DC	<input type="checkbox"/> * AIR/OIL	
MOTOR VOLTAGE	<input checked="" type="checkbox"/> 115	<input type="checkbox"/> 208	<input type="checkbox"/> 230	<input type="checkbox"/> 460
DEDICATED CIRCUIT REQUIRED				
MOTOR PHASE	<input checked="" type="checkbox"/> SINGLE	<input type="checkbox"/> THREE		
CONTROL	<input checked="" type="checkbox"/> HAND	<input type="checkbox"/> * FOOT		
~ ALL BATTERY CHARGERS ARE 115V AC ~				
* BATTERY CHRG.	<input type="checkbox"/> REMOTE	<input type="checkbox"/> ON-BOARD		
* CHRG. INDICATOR	<input type="checkbox"/> YES	<input type="checkbox"/> NO		

* AVAILABLE AT ADDITIONAL COST

APPROVAL

I, THE UNDERSIGNED, AGREE THAT THE PRODUCT AS REPRESENTED SATISFIES DESIGN AND DIMENSION REQUIREMENTS. I ALSO ACKNOWLEDGE MY DUTY TO CONFIRM PRODUCT AND INSTALLATION COMPLIANCE WITH ALL APPLICABLE FEDERAL, STATE AND LOCAL REGULATIONS AND STANDARDS.

UNITS REQUIRING APPROVAL DRAWINGS OR MODIFIED ARE NON-RETURNABLE

[] As drawn [] As marked

Signed: _____ Date: _____

Printed Name: _____

LEAD TIME WILL START UPON RECEIPT OF SIGNED APPROVAL DRAWING

DISTRIBUTOR'S NAME: _____ P.O.#

VESTIL MANUFACTURING W.O.#

DRAWN BY: CRM DATE: 10/21/2010 SALES:

REFERENCE: X SCALE: 1:28 FILE NAME: _____

QUOTED LEAD TIME: X QUOTE # 09-007-127-001