

STANDARD SLOPE LADDER, ELECTROSTATIC DISCHARGE, 12-STEP - LAD-PW-26-12-G-ESD

APPROX WEIGHT: 259.94 lbs.
DOES NOT INCLUDE WEIGHT OF POWER OR PACKAGING!!!

*** ANY ADDITIONS, DELETIONS, OR OMISSIONS MUST BE CORRECTED ON THIS DRAWING AS THIS DRAWING WILL BE CONSIDERED ALL INCLUSIVE ***
ALL GRAPHICS PROVIDED ARE FOR REFERENCE ONLY. IF CERTAIN DIMENSIONS ARE CRITICAL PLEASE VERIFY THOSE DIMENSIONS WITH YOUR SALESPERSON

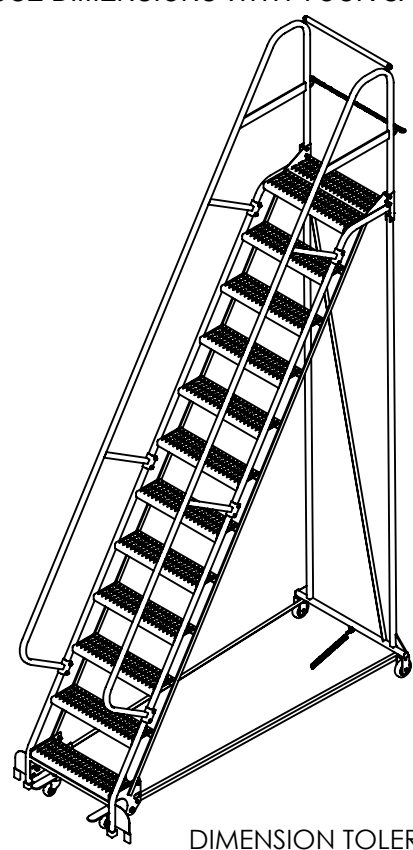
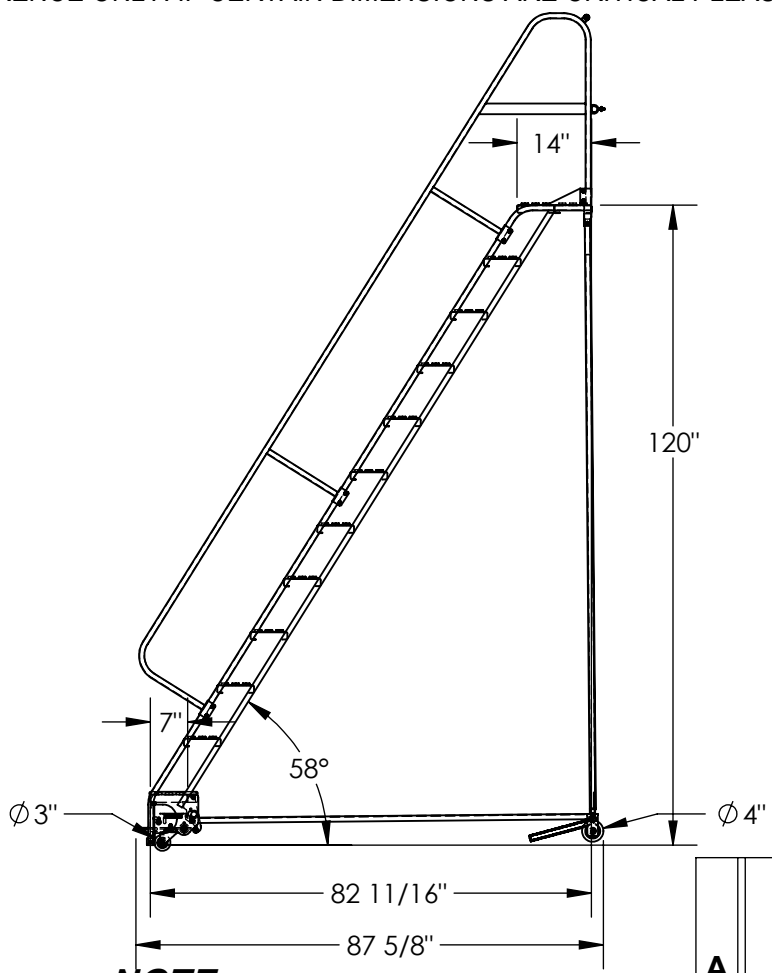
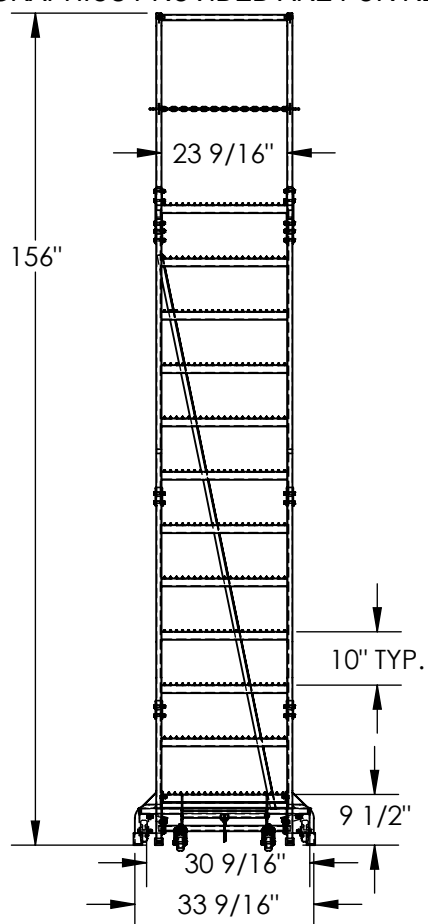

DIMENSION TOLERANCE ± 1/4"

STANDARD FEATURES

- MODEL NUMBER IS LAD-PW-26-12-G-ESD
- OVERALL WIDTH IS 33 9/16"
- USABLE WIDTH IS 23 9/16"
- OVERALL LENGTH IS 87 5/8"
- USABLE LENGTH IS 82 11/16"
- OVERALL HEIGHT IS 156"
- PLATFORM HEIGHT IS 120"
- STEP TYPE IS GRIP STRUT
- CLIMB ANGLE IS 58°
- STEP DEPTH IS 7"
- PLATFORM DEPTH IS 14"
- TOUGH BAKED IN POWDER COATED BLACK ESD FINISH
- MAX CAPACITY IS 350 LBS
- FRONT WHEEL IS SWIVEL, SIZE IS Ø 3"
- REAR WHEEL IS RIGID, SIZE IS Ø 4"

NOTE

- SOME ASSEMBLY REQUIRED
- TOOL TRAY SOLD SEPARATELY
- OPTIONAL ESD GROUNDING STRAPS SOLD SEPERATELY

SPECIAL FEATURES

NONE

APPROVAL

I, THE UNDERSIGNED, AGREE THAT THE PRODUCT AS REPRESENTED SATISFIES DESIGN AND DIMENSION REQUIREMENTS. I ALSO ACKNOWLEDGE MY DUTY TO CONFIRM PRODUCT AND INSTALLATION COMPLIANCE WITH ALL APPLICABLE FEDERAL, STATE AND LOCAL REGULATIONS AND STANDARDS.

UNITS REQUIRING APPROVAL DRAWINGS OR MODIFIED ARE NON-RETURNABLE

[] As drawn [] As marked

Signed: _____ Date: _____

LEAD TIME WILL START UPON RECEIPT OF SIGNED APPROVAL DRAWING

DISTRIBUTOR'S NAME:		P.O.#
VESTIL MANUFACTURING		X
DRAWN BY:	DATE:	W.O.#
B.NOTHNAGEL	9/21/2015	X
REFERENCE:	SCALE:	SALES:
X	1:36	X
QUOTED LEAD TIME:	QUOTE #	FILE NAME:
X	X	44-007-503