

POWERED QUICK LIFT - PEL-400S-72-D3-AHI

APPROX WEIGHT: 389.11 lbs.
DOES NOT INCLUDE WEIGHT OF POWER OR PACKAGING!!!

*** ANY ADDITIONS, DELETIONS, OR OMISSIONS MUST BE CORRECTED ON THIS DRAWING AS THIS DRAWING WILL BE CONSIDERED ALL INCLUSIVE ***

ALL GRAPHICS PROVIDED ARE FOR REFERENCE ONLY. IF CERTAIN DIMENSIONS ARE CRITICAL PLEASE VERIFY THOSE DIMENSIONS WITH YOUR SALESPERSON

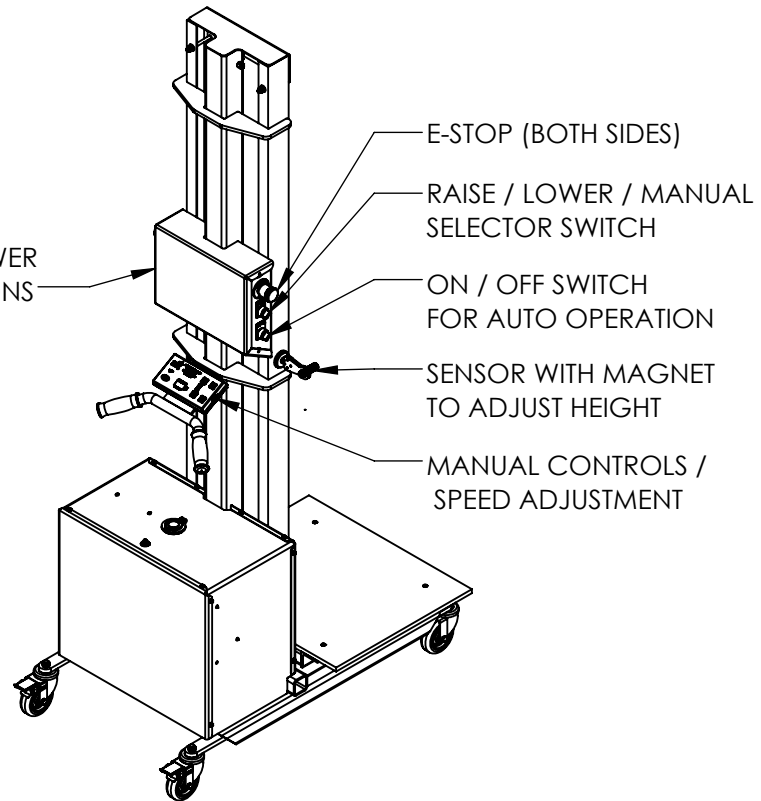
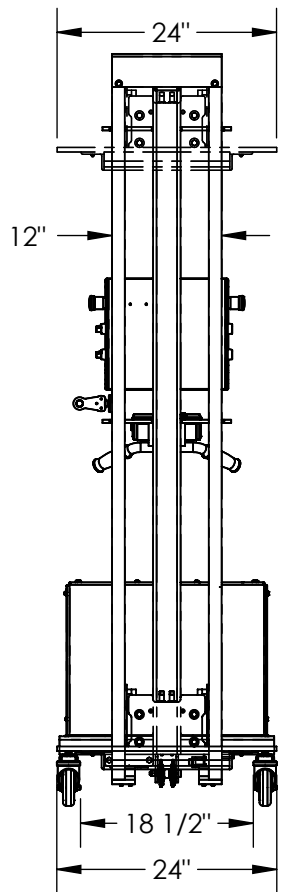
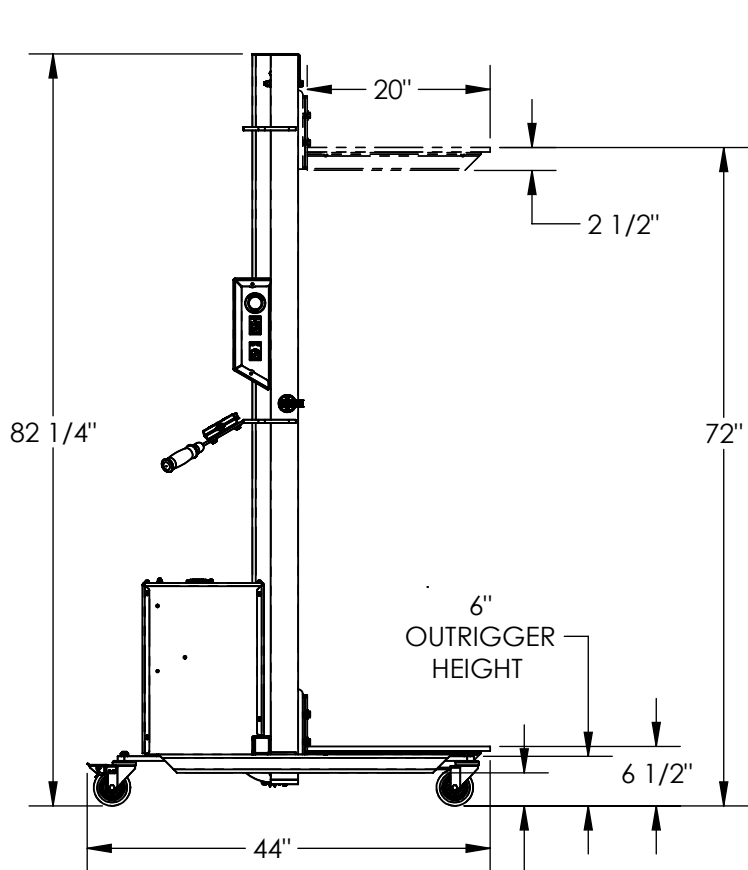

STANDARD FEATURES

- MODEL NUMBER: PEL-400S-72-D3-AHI
- STEEL CONSTRUCTION
- CAPACITY: 400 LBS
- PLATFORM WIDTH: 24"
- PLATFORM LENGTH: 20"
- LOWERED PLATFORM HEIGHT: 6 1/2"
- RAISED PLATFORM HEIGHT: 72"
- OVERALL SIZE 24"W x 44"L x 82 1/4"
- AUTO-HEIGHT INDEXING WITH ADJUSTABLE HEIGHT SENSOR
- 3-POSITION SELECTOR SWITCH (AUTO RAISE / AUTO LOWER / MANUAL MODE)
 - AUTO RAISE (LOAD WILL RAISE TO SENSOR HEIGHT)
 - AUTO LOWER (LOAD WILL LOWER TO SENSOR HEIGHT)
 - MANUAL (CONTINUOUS PUSH OPERATION RAISE AND LOWER)
- Ø 4" POLY-ON-POLY STEM CASTERS (2 SWIVEL W/ BRAKES & 2 RIGID)
- TOUGH BAKED IN POWDER COATED BLUE FINISH

SPECIAL FEATURES

NONE

24V DC POWER

ON-BOARD BATTERY
INDICATOR & CHARGER
CONTACT FACTORY FOR
OTHER POWER OPTIONS

DIMENSION TOLERANCE ± 1/4"

APPROVAL

I, THE UNDERSIGNED, AGREE THAT THE PRODUCT AS REPRESENTED SATISFIES DESIGN AND DIMENSION REQUIREMENTS. I ALSO ACKNOWLEDGE MY DUTY TO CONFIRM PRODUCT AND INSTALLATION COMPLIANCE WITH ALL APPLICABLE FEDERAL, STATE AND LOCAL REGULATIONS AND STANDARDS.

UNITS REQUIRING APPROVAL DRAWINGS OR MODIFIED ARE NON-RETURNABLE

[] As drawn [] As marked

Signed: _____ Date: _____

Printed Name: _____

LEAD TIME WILL START UPON RECEIPT OF SIGNED APPROVAL DRAWING

DISTRIBUTOR'S NAME:		P.O.#
VESTIL MANUFACTURING		X
DRAWN BY: TROY N.		DATE: 5/20/2024
REFERENCE: X		SCALE: 1:21
QUOTED LEAD TIME: X		QUOTE # X
		SALES: X
		FILE NAME: 21-007-060-001