

PALLET MASTER FORK EXTENSIONS 6" x 48" - PM-FE-6-48

APPROX WEIGHT: 39 lbs.
 DOES NOT INCLUDE WEIGHT OF POWER OR PACKAGING!!!

*** ANY ADDITIONS, DELETIONS, OR OMISSIONS MUST BE CORRECTED ON THIS DRAWING AS THIS DRAWING WILL BE CONSIDERED ALL INCLUSIVE ***

ALL GRAPHICS PROVIDED ARE FOR REFERENCE ONLY. IF CERTAIN DIMENSIONS ARE CRITICAL PLEASE VERIFY THOSE DIMENSIONS WITH YOUR SALESPERSON

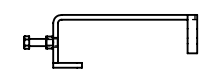
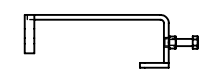
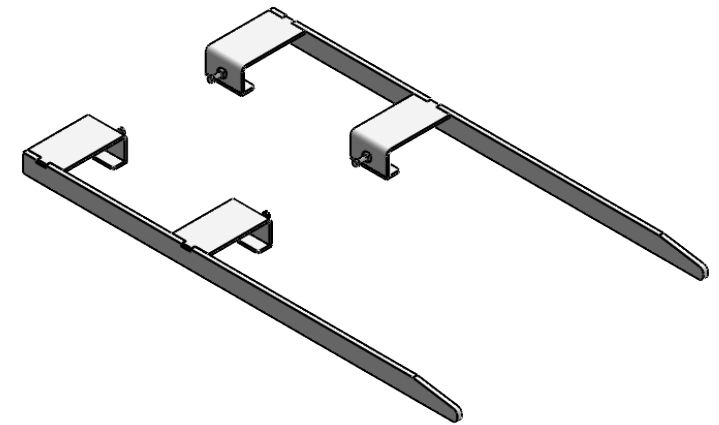
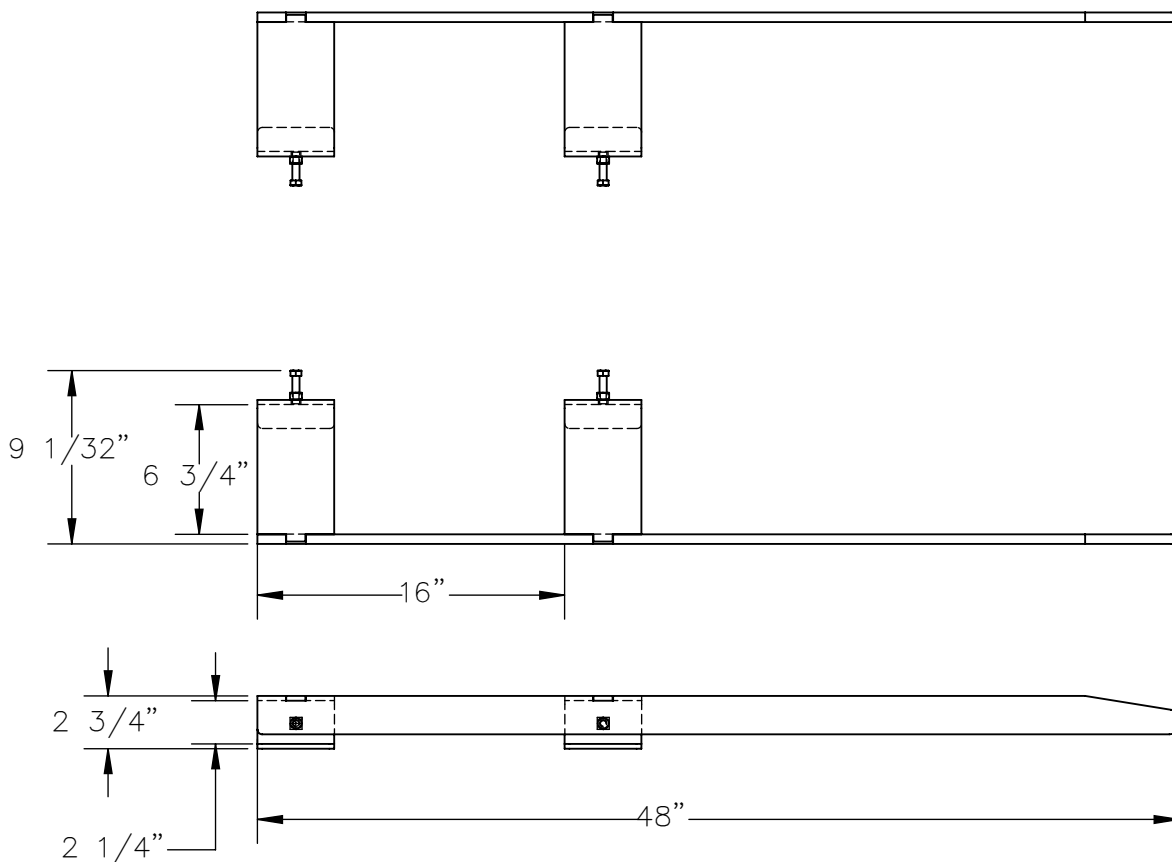

DIMENSION TOLERANCE ± 1/4"

STANDARD FEATURES

- MODEL NO: PM-FE-6-48
- OVERALL LENGTH IS: 48"
- OVERALL WIDTH IS: 9 1/32"
- OVERALL HEIGHT IS: 2 3/4"
- USABLE FORK POCKET WIDTH: 6"-6 5/8"
- USABLE FORK POCKET HEIGHT: 1 5/8"-2 1/8"
- MAXIMUM UNIFORM CAPACITY: 4,000 LB.
 (NOT TO EXCEED THE CAPACITY OF THE PALLET JACK)
- FOR USE WITH NOMINAL 6" WIDE FORKS ONLY
- DURABLE BAKED IN POWDER COATED YELLOW FINISH

SPECIAL FEATURES

NONE

APPROVAL	I, THE UNDERSIGNED, AGREE THAT THE PRODUCT AS REPRESENTED SATISFIES DESIGN AND DIMENSION REQUIREMENTS. I ALSO ACKNOWLEDGE MY DUTY TO CONFIRM PRODUCT AND INSTALLATION COMPLIANCE WITH ALL APPLICABLE FEDERAL, STATE AND LOCAL REGULATIONS AND STANDARDS.	
	UNITS REQUIRING APPROVAL DRAWINGS OR MODIFIED ARE NON-RETURNABLE	
	[] As drawn [] As marked	
Signed: _____		Date: _____
Printed Name: _____		
<i>LEAD TIME WILL START UPON RECEIPT OF SIGNED APPROVAL DRAWING</i>		

DISTRIBUTOR'S NAME:		P.O.#
VESTIL MANUFACTURING		X
		W.O.#
DRAWN BY: EAG		X
DATE: 6/12/2026		SALES: X
REFERENCE: X	SCALE: 1:10	FILE NAME:
QUOTED LEAD TIME: X	QUOTE # X	15-007-170