

# EDGE-O-DOCKLEVELER - PP-1572-36

APPROX WEIGHT: 662.26 lbs.  
DOES NOT INCLUDE WEIGHT OF POWER OR PACKAGING!!!

\*\*\* ANY ADDITIONS, DELETIONS, OR OMISSIONS MUST BE CORRECTED ON THIS DRAWING AS THIS DRAWING WILL BE CONSIDERED ALL INCLUSIVE \*\*\*  
ALL GRAPHICS PROVIDED ARE FOR REFERENCE ONLY. IF CERTAIN DIMENSIONS ARE CRITICAL PLEASE VERIFY THOSE DIMENSIONS WITH YOUR SALESPERSON

\*\*HAND PUMP NOT SHOWN IN FRONT OR RIGHT VIEW\*\*

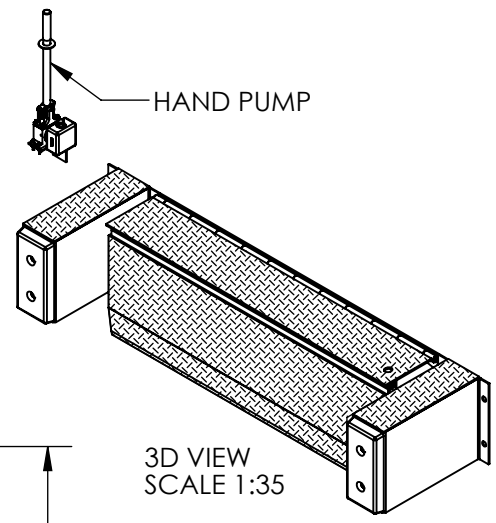
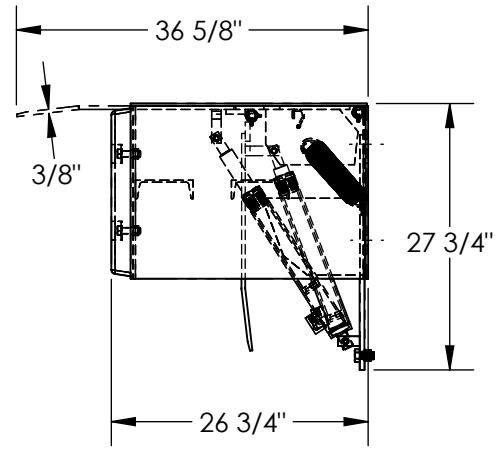
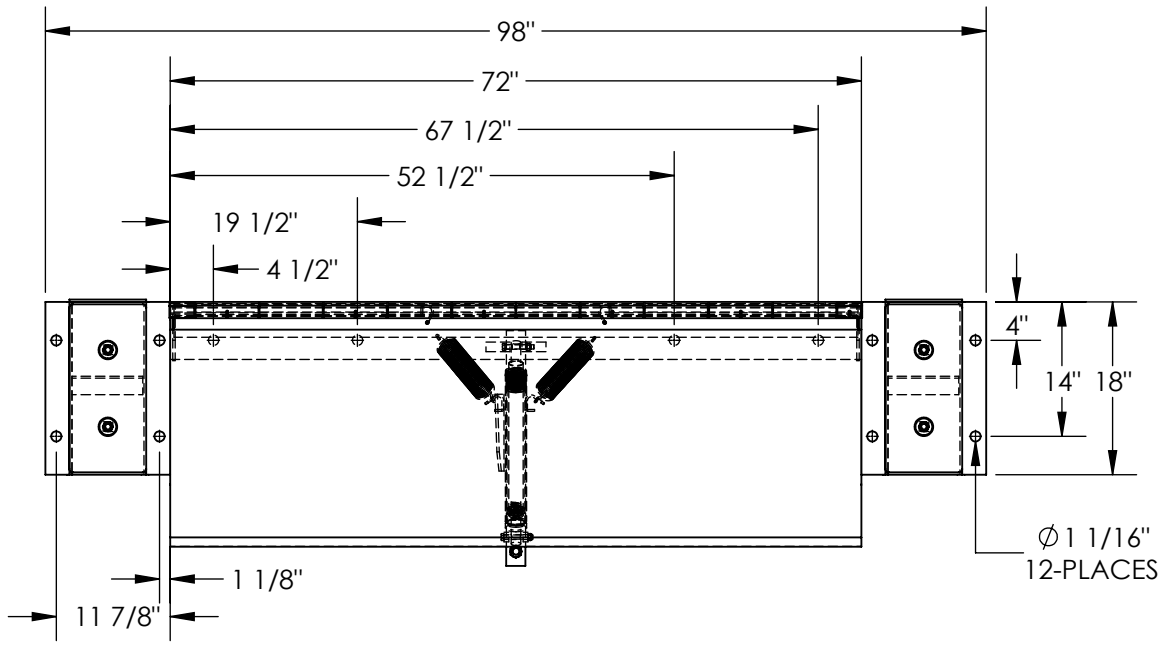

3D VIEW  
SCALE 1:35

DIMENSION TOLERANCE ± 1/4"

## STANDARD FEATURES

- MODEL NUMBER IS PP-1572-36
- OVERALL WIDTH IS 98"
- DECK WIDTH IS 72"
- OVERALL DEPTH WITH RAMP OUT IS 36 5/8"
- BUMPER PROJECTION IS 26 3/4"
- UNIFORM CAPACITY IS 15,000 LBS.
- 5" ABOVE / 5" BELOW SERVICE RANGE
- RECOMMENDED FOR DOCKS AT LEAST 48" HIGH
- HYDRAULIC HAND PUMP OPERATION
- INCLUDES HAND PUMP, WALL-MOUNT BRACKET, CYLINDER, HYDRAULIC LINES AND OIL.
- TREADPLATE RAMP & DECK CONSTRUCTION
- DURABLE LIQUID PAINT BROWN FINISH

## SPECIAL FEATURES

NONE

<b>APPROVAL</b>	I, THE UNDERSIGNED, AGREE THAT THE PRODUCT AS REPRESENTED SATISFIES DESIGN AND DIMENSION REQUIREMENTS. I ALSO ACKNOWLEDGE MY DUTY TO CONFIRM PRODUCT AND INSTALLATION COMPLIANCE WITH ALL APPLICABLE FEDERAL, STATE AND LOCAL REGULATIONS AND STANDARDS.	
	<b>UNITS REQUIRING APPROVAL DRAWINGS OR MODIFIED ARE NON-RETURNABLE</b>	
	[ ] As drawn      [ ] As marked	
Signed: _____		Date: _____
Printed Name: _____		
<b>LEAD TIME WILL START UPON RECEIPT OF SIGNED APPROVAL DRAWING</b>		

DISTRIBUTOR'S NAME:		P.O.#
VESTIL MANUFACTURING		X
DRAWN BY: M. WILSON		W.O.#
DATE: 1/8/2013		X
REFERENCE: X	SCALE: 1:20	SALES: X
QUOTED LEAD TIME: X	QUOTE # X	FILE NAME:
		06-007-061