

# EDGE-O-DOCKLEVELER - PP-2572

APPROX WEIGHT: 602.34 lbs.  
DOES NOT INCLUDE WEIGHT OF POWER OR PACKAGING!!!

\*\*\* ANY ADDITIONS, DELETIONS, OR OMISSIONS MUST BE CORRECTED ON THIS DRAWING AS THIS DRAWING WILL BE CONSIDERED ALL INCLUSIVE \*\*\*

ALL GRAPHICS PROVIDED ARE FOR REFERENCE ONLY. IF CERTAIN DIMENSIONS ARE CRITICAL PLEASE VERIFY THOSE DIMENSIONS WITH YOUR SALESPERSON

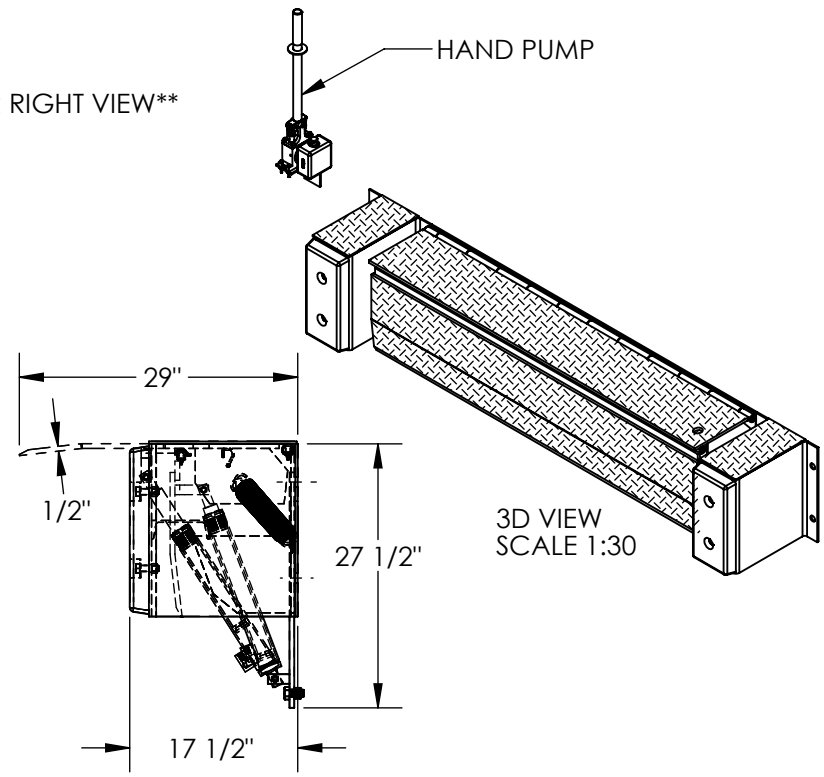
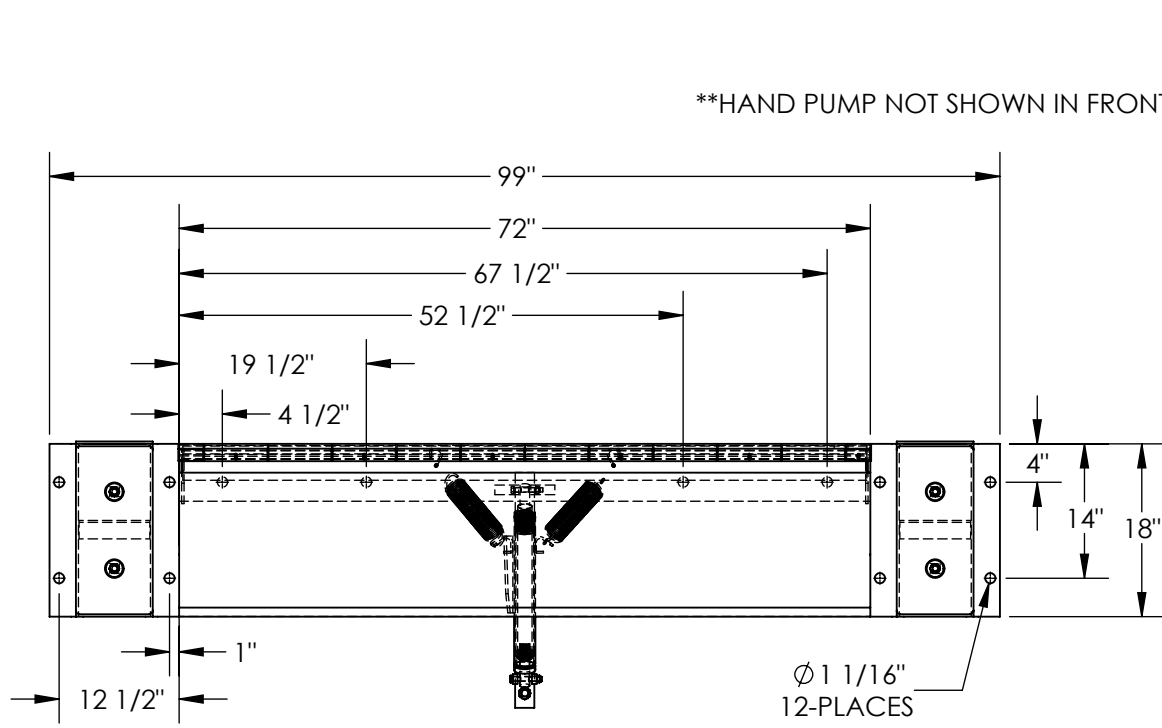

DIMENSION TOLERANCE ± 1/4"

## STANDARD FEATURES

- MODEL NUMBER IS PP-2572
- OVERALL WIDTH IS 99"
- DECK WIDTH IS 72"
- OVERALL DEPTH WITH RAMP OUT IS 29"
- BUMPER PROJECTION IS 17 1/2"
- UNIFORM CAPACITY IS 25,000 LBS.
- 5" ABOVE / 5" BELOW SERVICE RANGE
- HYDRAULIC HAND PUMP OPERATION
- RECOMMENDED FOR DOCKS AT LEAST 48" HIGH.
- INCLUDES HAND PUMP, WALL-MOUNT BRACKET, CYLINDER, HYDRAULIC LINES AND OIL.
- TREADPLATE RAMP & DECK CONSTRUCTION
- DURABLE LIQUID PAINT BROWN FINISH

## SPECIAL FEATURES

NONE

<b>APPROVAL</b>	I, THE UNDERSIGNED, AGREE THAT THE PRODUCT AS REPRESENTED SATISFIES DESIGN AND DIMENSION REQUIREMENTS. I ALSO ACKNOWLEDGE MY DUTY TO CONFIRM PRODUCT AND INSTALLATION COMPLIANCE WITH ALL APPLICABLE FEDERAL, STATE AND LOCAL REGULATIONS AND STANDARDS.	
	<b>UNITS REQUIRING APPROVAL DRAWINGS OR MODIFIED ARE NON-RETURNABLE</b>	
	[ ] As drawn      [ ] As marked	
	Signed: _____ Date: _____	
Printed Name: _____		
<i>LEAD TIME WILL START UPON RECEIPT OF SIGNED APPROVAL DRAWING</i>		

DISTRIBUTOR'S NAME:		P.O.#
VESTIL MANUFACTURING		X
DRAWN BY: M.WILSON		DATE: 12/19/2012
REFERENCE: X		SCALE: 1:20
QUOTED LEAD TIME: X		QUOTE # X
		SALES: X
		FILE NAME: 06-007-005