

EDGE OF DOCK APPROACH RAMP

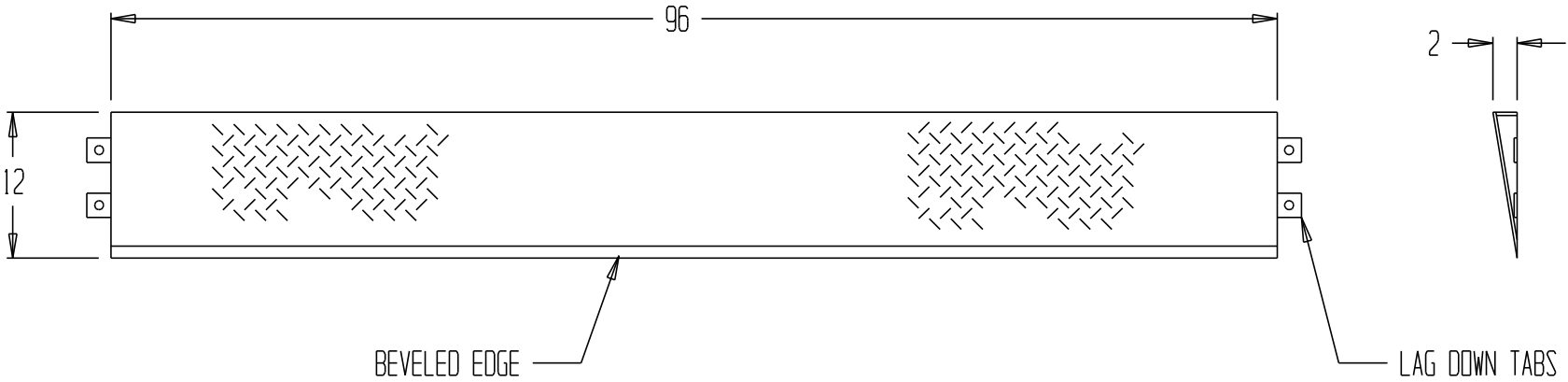

STANDARD FEATURES

MODEL NUMBER: RAMP-2
 CAPACITY: 20,000 LBS.
 OVERALL RAMP WIDTH IS 96 INCHES
 OVERALL LENGTH IS 12 INCHES
 OVERALL HEIGHT IS 2 INCHES
 4 LAG DOWN POINTS
 CONSTRUCTED OF STEEL TREADPLATE

***UNIT IS SPECIAL AND
 NON RETURNABLE***

PRODUCTION WILL START UPON
 RECEIPT OF SIGNED APPROVAL
 DRAWING

APPROVAL

I, the undersigned, hereby approve this print
 As drawn As marked
 This includes my approval of design & dimensions.
 Signed: _____
 Date: _____

DISTRIBUTOR'S NAME: <i>VESTIL MANUFACTURING CO.</i>		P.O.#: _____
DRAWN BY: BB		W.O.#: _____
DATE:		SALES:
REFERENCE: _____		DRWG./FILE NAME: RAMP-2
SCALE 1:16		