

SPIN TOP TRAILER STABILIZING JACK - SP-TOP-100

APPROX WEIGHT: 114.16 lbs.
DOES NOT INCLUDE WEIGHT OF POWER OR PACKAGING!!!

*** ANY ADDITIONS, DELETIONS, OR OMISSIONS MUST BE CORRECTED ON THIS DRAWING AS THIS DRAWING WILL BE CONSIDERED ALL INCLUSIVE ***

ALL GRAPHICS PROVIDED ARE FOR REFERENCE ONLY. IF CERTAIN DIMENSIONS ARE CRITICAL PLEASE VERIFY THOSE DIMENSIONS WITH YOUR SALESPERSON

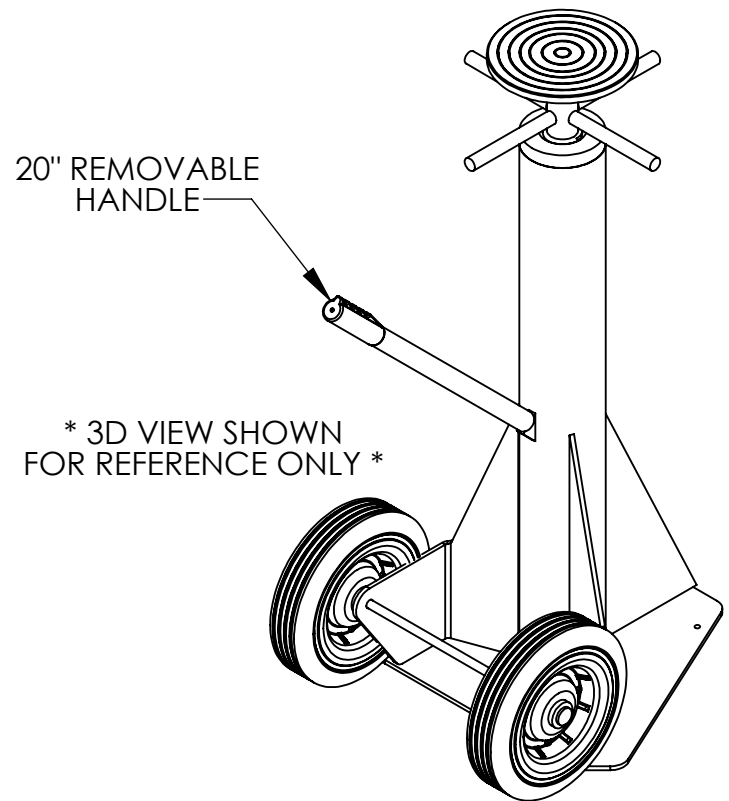
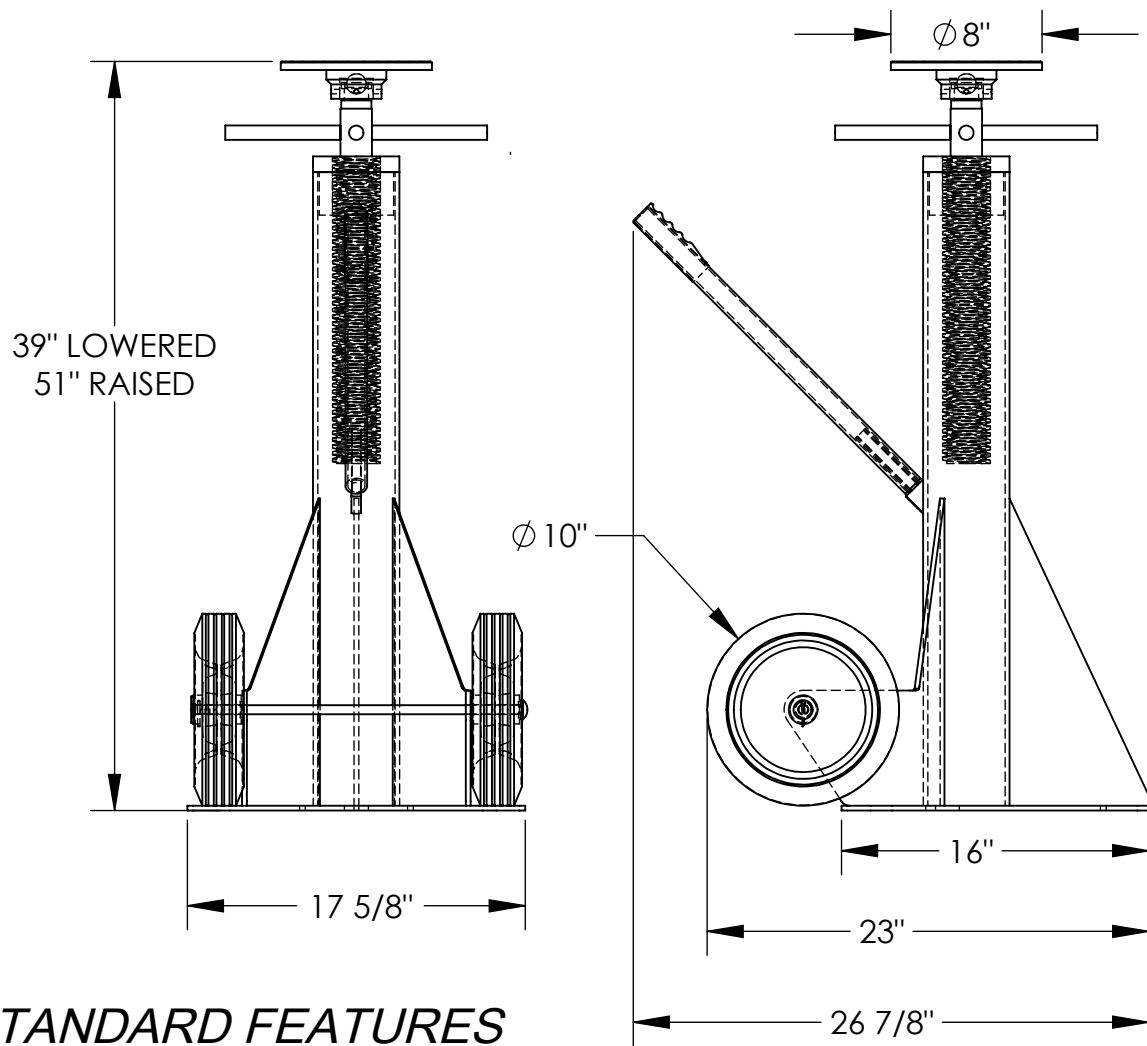

* 3D VIEW SHOWN FOR REFERENCE ONLY *

DIMENSION TOLERANCE $\pm 1/4"$

STANDARD FEATURES

- MODEL NUMBER: SP-TOP-100
- OVERALL WIDTH: 17 5/8"
- OVERALL LENGTH: 26 7/8"
- SERVICE RANGE: 39" TO 51"
- STATIC CAPACITY: 100,000 LBS.
- LIFTING CAPACITY: 50,000 LBS.
- TOP CAP: 8" DIAMETER
- WHEEL SIZE IS $\varnothing 10"$
- HANDLE LENGTH IS 20"

SPECIAL FEATURES

NONE

I, THE UNDERSIGNED, AGREE THAT THE PRODUCT AS REPRESENTED SATISFIES DESIGN AND DIMENSION REQUIREMENTS. I ALSO ACKNOWLEDGE MY DUTY TO CONFIRM PRODUCT AND INSTALLATION COMPLIANCE WITH ALL APPLICABLE FEDERAL, STATE AND LOCAL REGULATIONS AND STANDARDS.

ANY MODIFIED UNITS ARE NON-RETURNABLE

As drawn As marked

Signed: _____ Date: _____

Printed Name: _____

LEAD TIME WILL START UPON RECEIPT OF SIGNED APPROVAL DRAWING

APPROVAL

MAXIMUM WORKING CAPACITY AT GRADE(%)								
0.00%	0.50%	1.00%	1.50%	2.00%	2.50%	3.00%	3.50%	4.00%
100,000	80,000	66,000	55,000	46,000	41,000	37,000	33,000	29,000

FOR INTERNAL USE ONLY PROJECT SIGN OFF	
SALES	
ENG.	
FAB.	
POWER	

DISTRIBUTOR'S NAME:		P.O.#
VESTIL MANUFACTURING		X
DRAWN BY: BCN	DATE: 11/14/2017	W.O.#
REFERENCE: X	SCALE: 1:10	X
QUOTED LEAD TIME: X	QUOTE #	FILE NAME:
	X	13-007-074