

STEEL RAIL CHOCK - SRC/FRC

APPROX WEIGHT: 20.74 lbs.
 DOES NOT INCLUDE WEIGHT OF POWER OR PACKAGING!!!

*** ANY ADDITIONS, DELETIONS, OR OMISSIONS MUST BE CORRECTED ON THIS DRAWING AS THIS DRAWING WILL BE CONSIDERED ALL INCLUSIVE ***

ALL GRAPHICS PROVIDED ARE FOR REFERENCE ONLY. IF CERTAIN DIMENSIONS ARE CRITICAL PLEASE VERIFY THOSE DIMENSIONS WITH YOUR SALESPERSON

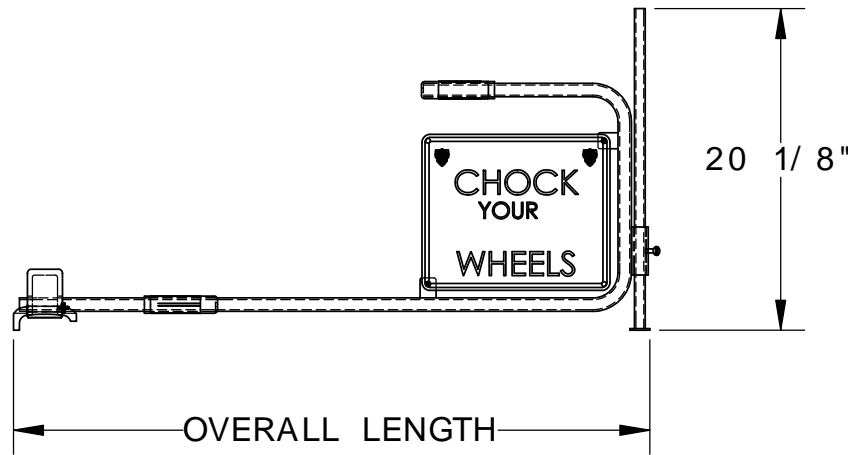
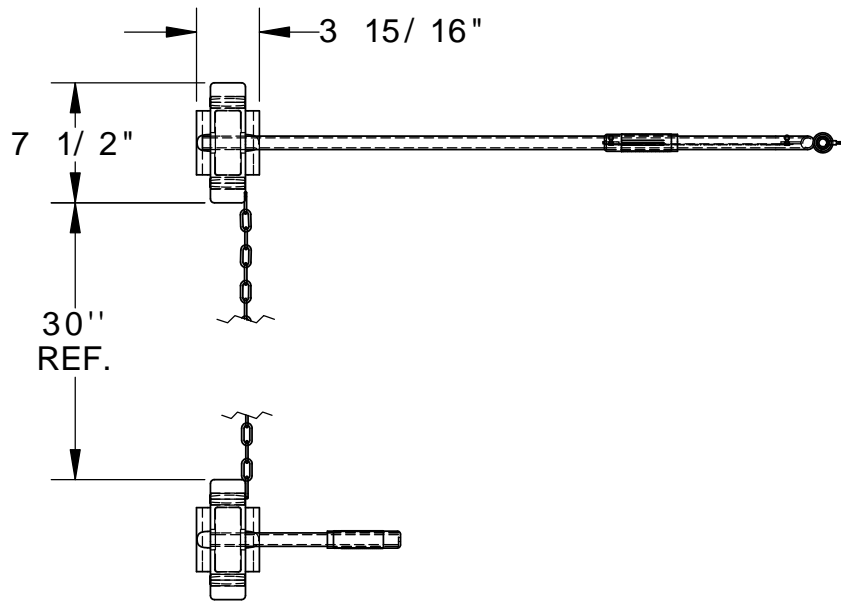

STANDARD FEATURES

MODEL NUMBER IS SRC/FRC
 CHOCK LENGTH IS 7 1/2"
 CHOCK WIDTH IS 3 15/16"
 OVERALL LENGTH IS 40 5/8"
 OVERALL HEIGHT IS 20 1/8"
 COMES WITH SIGN AND LEG
 30" CHOCK CONNECTOR CHAIN

SPECIAL FEATURES

NONE

DIMENSION TOLERANCE ± 1"

| | | |
|-----------------|--|-------------|
| APPROVAL | I, THE UNDERSIGNED, AGREE THAT THE PRODUCT AS REPRESENTED SATISFIES DESIGN AND DIMENSION REQUIREMENTS. I ALSO ACKNOWLEDGE MY DUTY TO CONFIRM PRODUCT AND INSTALLATION COMPLIANCE WITH ALL APPLICABLE FEDERAL, STATE AND LOCAL REGULATIONS AND STANDARDS. | |
| | ALL SPECIAL UNITS ARE NON-RETURNABLE <input type="checkbox"/> As drawn <input type="checkbox"/> As marked | |
| | Signed: _____ | Date: _____ |
| | LEAD TIME WILL START UPON RECEIPT OF SIGNED APPROVAL DRAWING | |

| | | |
|----------------------|----------------|-----------------------|
| DISTRIBUTOR'S NAME: | | P.O.# |
| VESTIL MANUFACTURING | | X |
| DRAWN BY: X | DATE: XX/XX/XX | W.O.# X |
| REFERENCE: X | SCALE: 1:12 | SALES: X |
| QUOTED LEAD TIME: X | QUOTE # X | FILE NAME: 29-007-025 |