

# CENTRAL PICK UP LOOP FOR STEEL WHEEL RISERS: SWR-CPL-18-12-96

APPROX WEIGHT: 804.27 lbs.  
 DOES NOT INCLUDE WEIGHT OF POWER OR PACKAGING!!!

\*\*\* ANY ADDITIONS, DELETIONS, OR OMISSIONS MUST BE CORRECTED ON THIS DRAWING AS THIS DRAWING WILL BE CONSIDERED ALL INCLUSIVE \*\*\*

ALL GRAPHICS PROVIDED ARE FOR REFERENCE ONLY. IF CERTAIN DIMENSIONS ARE CRITICAL PLEASE VERIFY THOSE DIMENSIONS WITH YOUR SALESPERSON

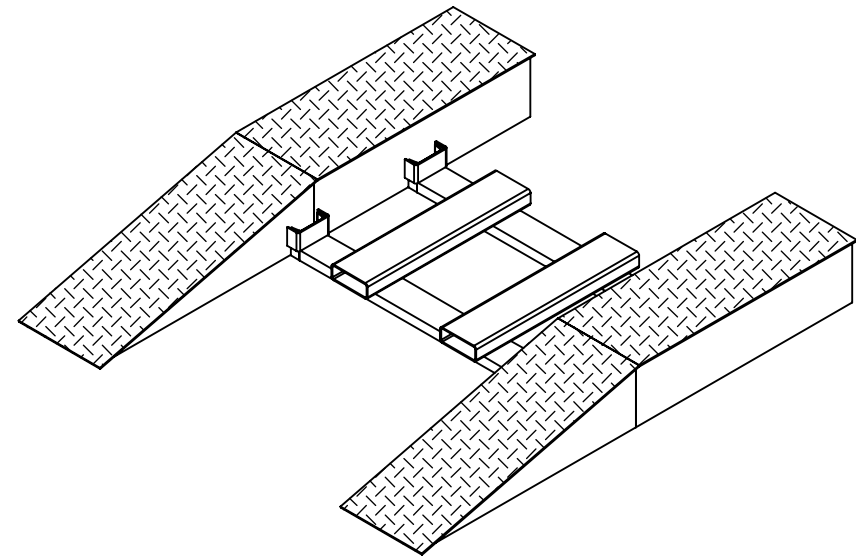
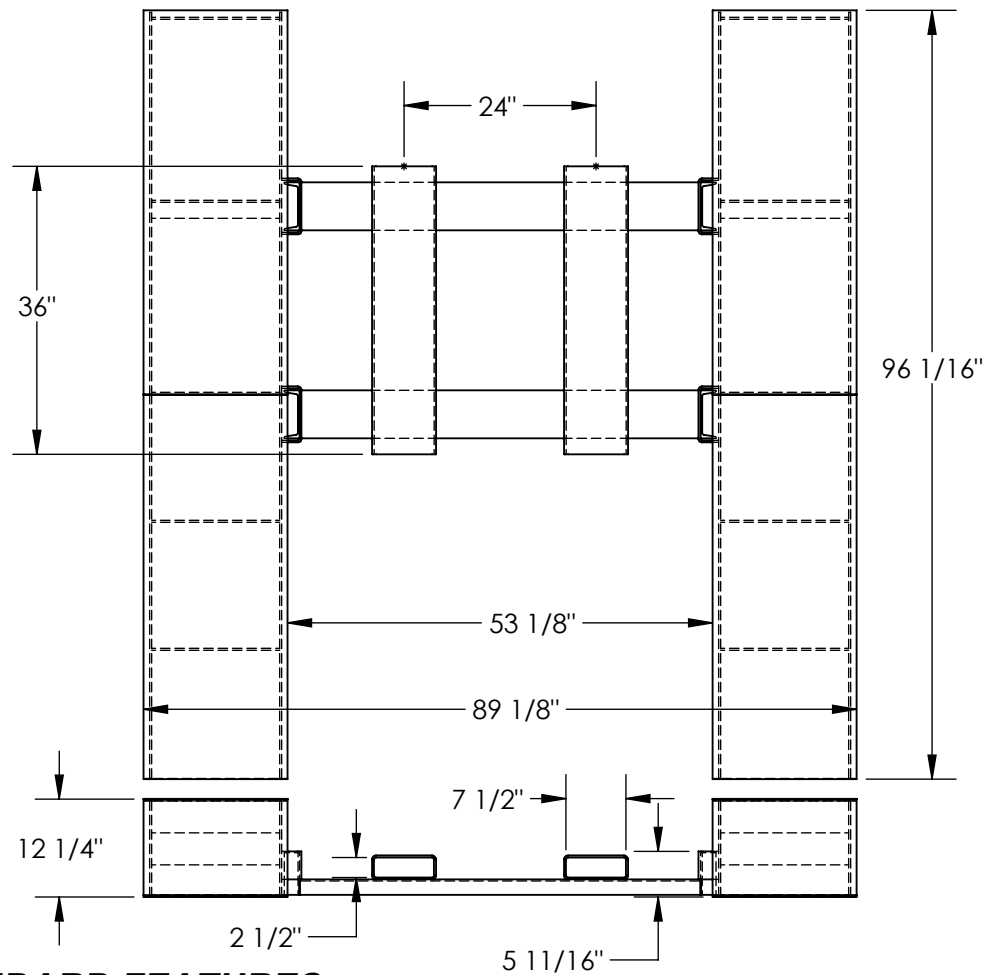

DIMENSION TOLERANCE ± 1/4"

## STANDARD FEATURES

- MODEL NUMBER IS SWR-CPL-18-12-96
- OVERALL WIDTH IS 89 1/8"
- WIDTH BETWEEN RISERS WHEN INSTALLED: 53 1/8"
- OVERALL HEIGHT: 12 1/4"
- HEIGHT FROM GROUND TO TOP OF SIDE LOOPS WHEN INSTALLED: 5 11/16"
- OVERALL DEPTH: 96 1/16"
- 7 1/2"W x 2 1/2"H USABLE FORK POCKETS ON 24" CENTERS
- FORK ATTACHMENT INSERTS INTO LOOPS WELDED TO INNER SIDES OF WHEEL RISERS
- STEEL CONSTRUCTION
- DURABLE LIQUID PAINT BROWN FINISH

## SPECIAL FEATURES

NONE

<b>APPROVAL</b>	I, THE UNDERSIGNED, AGREE THAT THE PRODUCT AS REPRESENTED SATISFIES DESIGN AND DIMENSION REQUIREMENTS. I ALSO ACKNOWLEDGE MY DUTY TO CONFIRM PRODUCT AND INSTALLATION COMPLIANCE WITH ALL APPLICABLE FEDERAL, STATE AND LOCAL REGULATIONS AND STANDARDS.	
	<b>UNITS REQUIRING APPROVAL DRAWINGS OR MODIFIED ARE NON-RETURNABLE</b>	
	[ ] As drawn      [ ] As marked	
	Signed: _____	Date: _____
Printed Name: _____		
LEAD TIME WILL START UPON RECEIPT OF SIGNED APPROVAL DRAWING		

DISTRIBUTOR'S NAME:		P.O.#
VESTIL MANUFACTURING		X
DRAWN BY: T.HARKRADER		DATE: 4/17/2023
REFERENCE: X		SCALE: 1:20
QUOTED LEAD TIME: X		QUOTE #
		X
		FILE NAME:
		18-007-408