

TRASH DRUM DUMPER - T-HOP

APPROX WEIGHT: 569.65 lbs.
DOES NOT INCLUDE WEIGHT OF POWER OR PACKAGING!!!

ANY ADDITIONS, DELETIONS, OR OMISSIONS MUST BE CORRECTED ON THIS DRAWING AS THIS DRAWING WILL BE CONSIDERED ALL INCLUSIVE

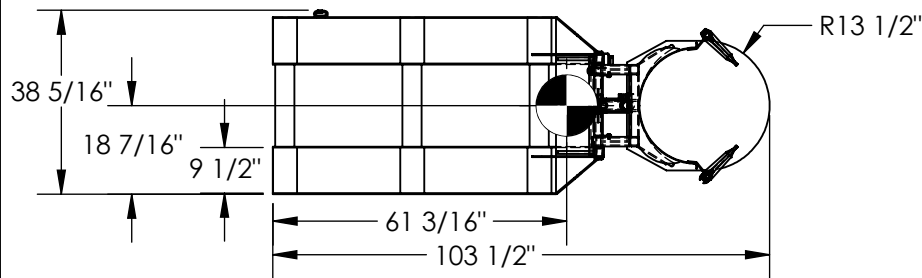

3-D VIEW OF T-HOP WITH D-200-LD SHOWN FOR REFERENCE ONLY

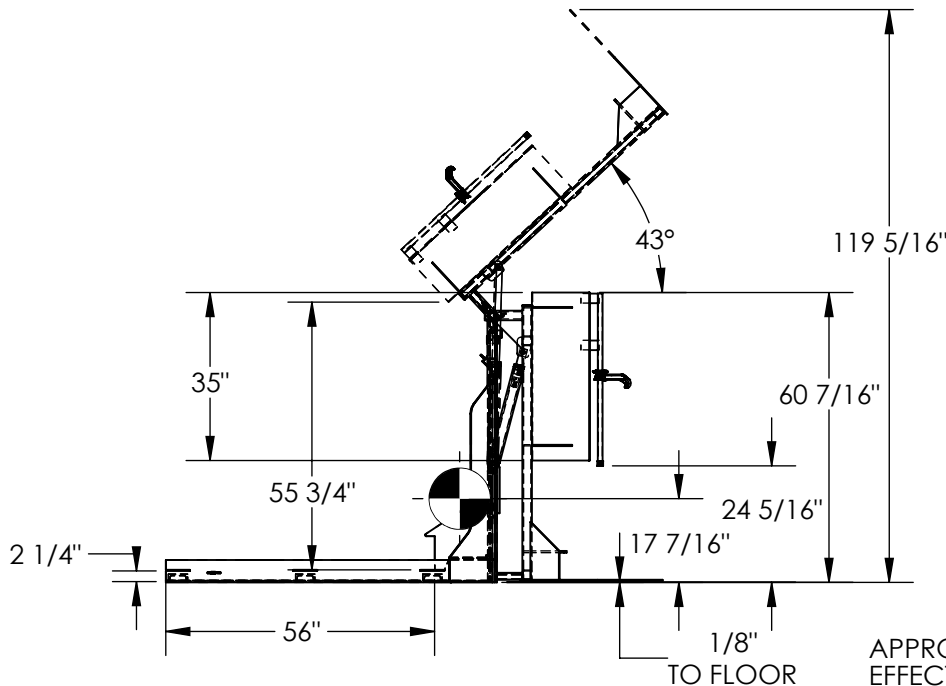
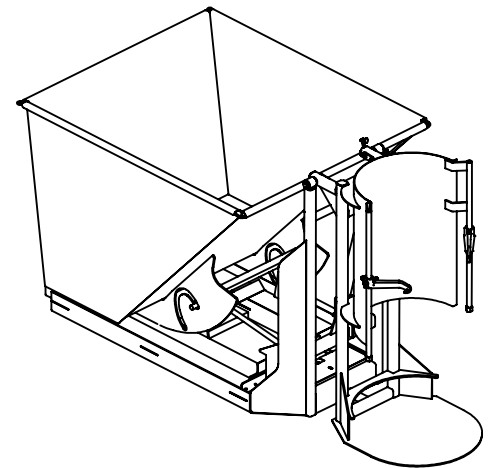

APPROX. WEIGHT/ LOST LOAD= 570 LBS. (APPROX)
EFFECTIVE THICKNESS= FORK LENGTH MINUS 59"
FOR FORK LENGTHS 59" OR SHORTER
MINIMUM EFFECTIVE THICKNESS= LESS THAN 1"
NEVER EXCEED LOAD CENTER RATING PER FORK
TRUCK MANUFACTURER'S GUIDELINES.
DO NOT USE THIS FORK TRUCK ATTACHMENT IF
LOAD WILL EXCEED FORK TRUCK
MANUFACTURER'S LOAD CENTER RATING.

ALL GRAPHICS PROVIDED ARE FOR REFERENCE ONLY. IF CERTAIN DIMENSIONS ARE CRITICAL PLEASE VERIFY THOSE DIMENSIONS WITH YOUR SALESPERSON

STANDARD FEATURES

- MODEL NUMBER IS T-HOP
- DUMPER HOLDS 55 GAL DRUM
- DUMPER CAPACITY IS 400 LBS
- OVERALL WIDTH IS 38 5/16"
- OVERALL LENGTH IS 103 1/2"
- OVERALL HEIGHT IS 60 7/16"
- OVERALL ROTATED HEIGHT IS 119 5/16"
- DUMP HEIGHT IS 55 3/4"
- DUMP ANGLE IS 43°
- DURABLE LIQUID PAINT YELLOW FINISH

- WORKS WITH 2 CUBIC YARD "D" STYLE HOPPERS
- HOPPERS SOLD SEPARATELY
- POWER UNIT: 12 V DC WITH ON-BOARD CHARGER
- CONTROL: HAND

SPECIAL FEATURES

NONE

DIMENSION TOLERANCE ± 1/4"

A P P R O V A L	I, THE UNDERSIGNED, AGREE THAT THE PRODUCT AS REPRESENTED SATISFIES DESIGN AND DIMENSION REQUIREMENTS. I ALSO ACKNOWLEDGE MY DUTY TO CONFIRM PRODUCT AND INSTALLATION COMPLIANCE WITH ALL APPLICABLE FEDERAL, STATE AND LOCAL REGULATIONS AND STANDARDS.	
	UNITS REQUIRING APPROVAL DRAWINGS OR MODIFIED ARE NON-RETURNABLE	
	[] As drawn [] As marked	
Signed: _____		Date: _____
Printed Name: _____		
<i>LEAD TIME WILL START UPON RECEIPT OF SIGNED APPROVAL DRAWING</i>		

DISTRIBUTOR'S NAME:		P.O.#
VESTIL MANUFACTURING		X
DRAWN BY: J. BRANDT		W.O.#
DATE: 07/16/09		X
REFERENCE: X		SALES: X
QUOTED LEAD TIME: X		SCALE: 1:40
QUOTE #		FILE NAME:
X		34-007-026