

WORK PLATFORM- WP-3648

APPROX WEIGHT: 260.37 lbs.
DOES NOT INCLUDE WEIGHT OF POWER OR PACKAGING!!!

*** ANY ADDITIONS, DELETIONS, OR OMISSIONS MUST BE CORRECTED ON THIS DRAWING AS THIS DRAWING WILL BE CONSIDERED ALL INCLUSIVE ***

ALL GRAPHICS PROVIDED ARE FOR REFERENCE ONLY. IF CERTAIN DIMENSIONS ARE CRITICAL PLEASE VERIFY THOSE DIMENSIONS WITH YOUR SALESPERSON

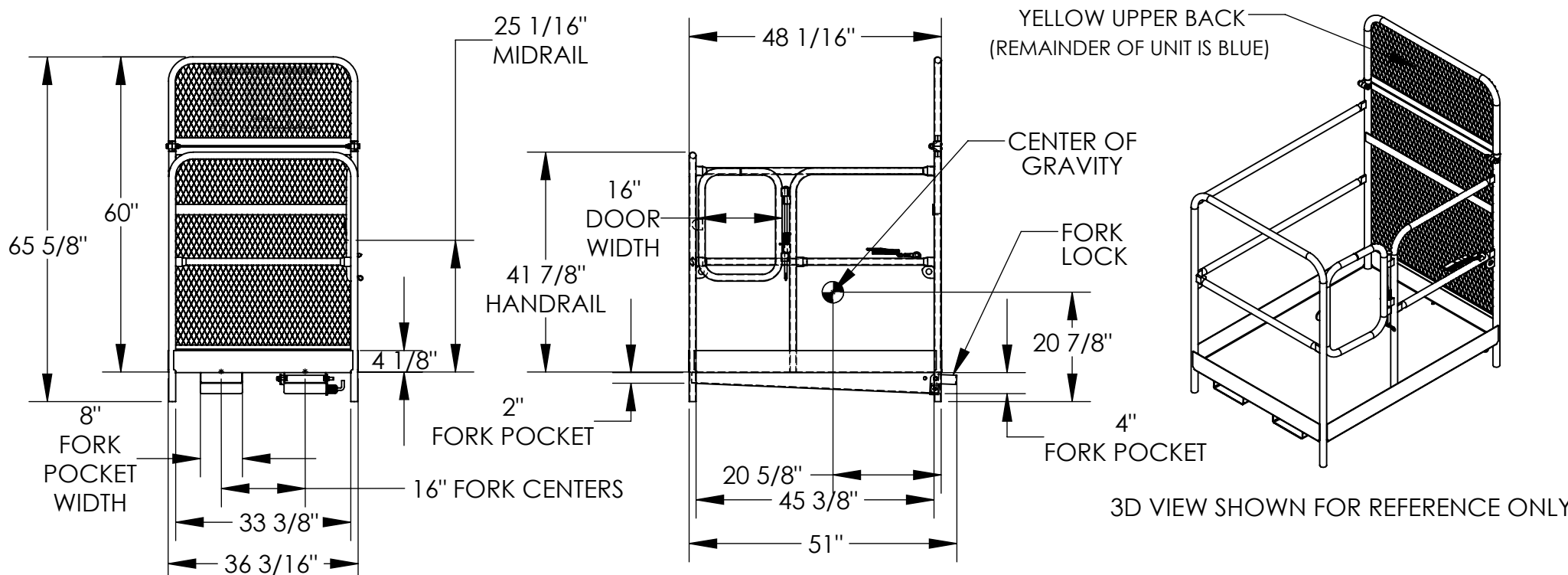

STANDARD FEATURES

- MODEL NUMBER IS WP-3648
- CAPACITY IS 1,000 LBS. (EVENLY DISTRIBUTED LOAD)
- OVERALL WIDTH IS 36 3/16"
- USABLE WIDTH IS 33 3/8"
- OVERALL LENGTH IS 51"
- USABLE LENGTH IS 45 3/8"
- 41 7/8" HIGH HANDRAIL WITH 25 1/16" MIDRAIL AND 4 1/8" TOEBOARD
- SELF-CLOSING DOOR SWINGS IN ONLY (WILL NOT OPEN OUT)
- FORK LOCK IS ROTATED UP BEHIND BACK OF FORK AND LOCKED WITH SPRING LOADED PLUNGER
- 36" LONG STRAP WITH HOOK (NOT SHOWN) MUST ATTACH PLATFORM TO FORK TRUCK
- 60" HIGH EXPANDED MESH BACKING
- USABLE FORK POCKET HEIGHTS: 3 7/8" REAR, 1 7/8" FRONT
- USABLE FORK POCKET WIDTH: 7 3/4"
- MANUFACTURED TO MEET OUR INTERPRETATION OF OSHA STANDARDS
- TOUGH BAKED IN POWDER COATED ERGO BLUE FINISH FRAME AND YELLOW UPPER BACK

SPECIAL FEATURES

NONE

APPROX. WEIGHT / LOST LOAD = 260.37
MINIMUM EFFECTIVE THICKNESS = >1"
NEVER EXCEED LOAD CENTER RATING PER FORKTRUCK MANUFACTURERS GUIDELINES.
DO NOT USE THIS FORK TRUCK ATTACHMENT IF LOAD WILL EXCEED FORK TRUCK MANUFACTURER'S LOAD CENTER RATING

DIMENSION TOLERANCE ± 1/4"

APPROVAL

I, THE UNDERSIGNED, AGREE THAT THE PRODUCT AS REPRESENTED SATISFIES DESIGN AND DIMENSION REQUIREMENTS. I ALSO ACKNOWLEDGE MY DUTY TO CONFIRM PRODUCT AND INSTALLATION COMPLIANCE WITH ALL APPLICABLE FEDERAL, STATE AND LOCAL REGULATIONS AND STANDARDS.

ANY MODIFIED UNITS ARE NON-RETURNABLE

As drawn As marked

Signed: _____ Date: _____

Printed Name: _____

LEAD TIME WILL START UPON RECEIPT OF SIGNED APPROVAL DRAWING

FOR INTERNAL USE ONLY PROJECT SIGN OFF	
SALES	
ENG.	
FAB.	
POWER	

DISTRIBUTOR'S NAME:		P.O.#
VESTIL MANUFACTURING		X
DRAWN BY:	DATE:	W.O.#
C.WOLF	08/31/06	X
REFERENCE:	SCALE:	SALES:
X	1:28	X
QUOTED LEAD TIME:	QUOTE #	FILE NAME:
X	X	14-007-002