

LINEARIZER ELECTRIC WORKER PLATFORM - WP-400-AIR

APPROX WEIGHT: 275.95 lbs.
 DOES NOT INCLUDE WEIGHT OF POWER OR PACKAGING!!!

*** ANY ADDITIONS, DELETIONS, OR OMISSIONS MUST BE CORRECTED ON THIS DRAWING AS THIS DRAWING WILL BE CONSIDERED ALL INCLUSIVE ***

ALL GRAPHICS PROVIDED ARE FOR REFERENCE ONLY. IF CERTAIN DIMENSIONS ARE CRITICAL PLEASE VERIFY THOSE DIMENSIONS WITH YOUR SALESPERSON

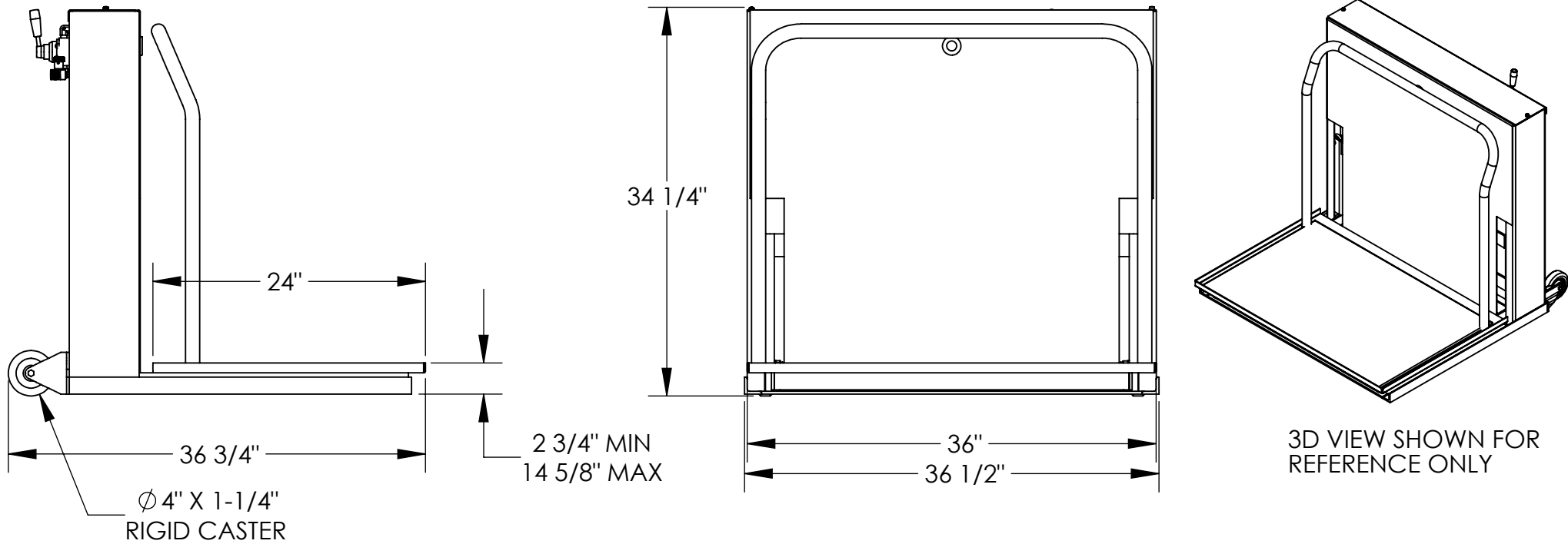

3D VIEW SHOWN FOR REFERENCE ONLY

STANDARD FEATURES

- MODEL NUMBER IS WP-400-AIR
- CAPACITY: 400 LBS.
- OVERALL WIDTH IS 36 1/2"
- USABLE WIDTH IS 36"
- OVERALL LENGTH IS 36 3/4"
- USABLE LENGTH IS 24"
- OVERALL HEIGHT IS 34 1/4"
- LOWERED HEIGHT: 2 3/4"
- RAISED HEIGHT: 14 5/8"
- (2) Ø4" X 1 1/4" POLY-ON-POLY RIGID CASTERS
- TOUGH BAKED IN POWDER COATED BLUE FINISH
- INCOMING AIR MUST BE CLEAN AND DRY

SPECIAL FEATURES

NONE

DIMENSION TOLERANCE ± 1/4"

APPROVAL

I, THE UNDERSIGNED, AGREE THAT THE PRODUCT AS REPRESENTED SATISFIES DESIGN AND DIMENSION REQUIREMENTS. I ALSO ACKNOWLEDGE MY DUTY TO CONFIRM PRODUCT AND INSTALLATION COMPLIANCE WITH ALL APPLICABLE FEDERAL, STATE AND LOCAL REGULATIONS AND STANDARDS.

ANY MODIFIED UNITS ARE NON-RETURNABLE

As drawn As marked

Signed: _____ Date: _____

Printed Name: _____

LEAD TIME WILL START UPON RECEIPT OF SIGNED APPROVAL DRAWING

STANDARD POWER FEATURES

REQUIRES 1/4" INCOMING AIRLINE.

FOR INTERNAL USE ONLY PROJECT SIGN OFF		DISTRIBUTOR'S NAME: VESTIL MANUFACTURING		P.O.# X
SALES		DRAWN BY: CRH	DATE: 2/15/2019	W.O.# X
ENG.		REFERENCE: X	SCALE: 1:13	SALES: X
FAB.		QUOTED LEAD TIME: X	QUOTE # X	FILE NAME: 21-007-144
POWER				