

# EXTRUDED ALUMINUM HOSE & CABLE CROSSOVER RAMP - WR-24-BK

APPROX WEIGHT: 0.94 lbs.  
 DOES NOT INCLUDE WEIGHT OF POWER OR PACKAGING!!!

\*\*\* ANY ADDITIONS, DELETIONS, OR OMISSIONS MUST BE CORRECTED ON THIS DRAWING AS THIS DRAWING WILL BE CONSIDERED ALL INCLUSIVE \*\*\*  
 ALL GRAPHICS PROVIDED ARE FOR REFERENCE ONLY. IF CERTAIN DIMENSIONS ARE CRITICAL PLEASE VERIFY THOSE DIMENSIONS WITH YOUR SALESPERSON

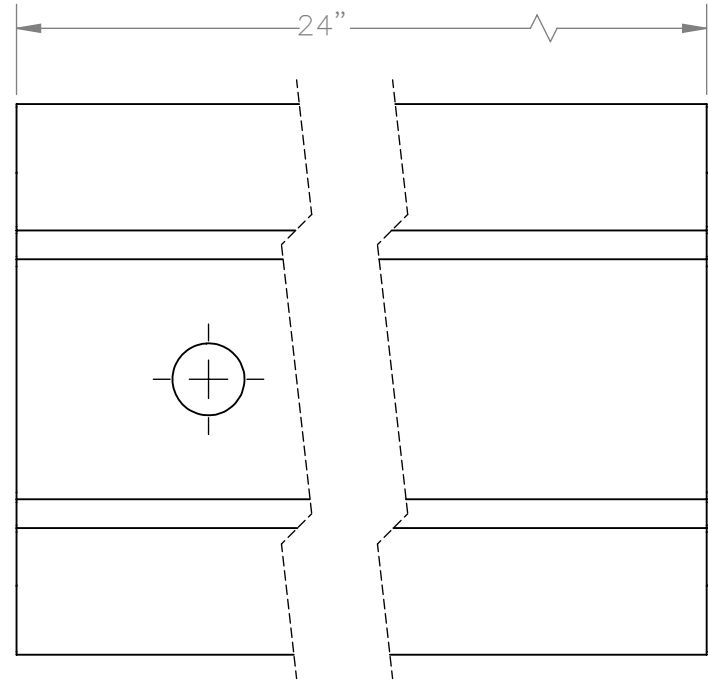
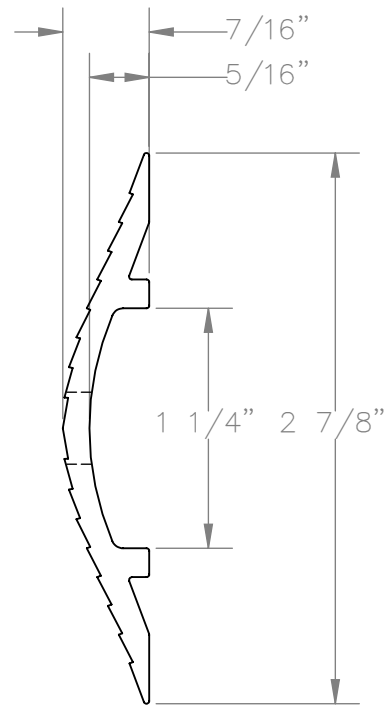

DIMENSION TOLERANCE ± 1/2"

**NOTE:** HOLE IS FOR POWDER COATED UNITS ONLY

**STANDARD FEATURES**

- MODEL NUMBER: WR-24-BK
- SINGLE WHEEL CAPACITY: 2,500 LBS
- OVERALL WIDTH: 2 7/8"
- OVERALL LENGTH: 24"
- OVERALL HEIGHT: 7/16"
- USABLE WIDTH: 1 1/4"
- USABLE HEIGHT: 5/16"
- FINISH: BLACK

**SPECIAL FEATURES**

NONE

**APPROVAL**

I, THE UNDERSIGNED, AGREE THAT THE PRODUCT AS REPRESENTED SATISFIES DESIGN AND DIMENSION REQUIREMENTS. I ALSO ACKNOWLEDGE MY DUTY TO CONFIRM PRODUCT AND INSTALLATION COMPLIANCE WITH ALL APPLICABLE FEDERAL, STATE AND LOCAL REGULATIONS AND STANDARDS.

**ANY MODIFIED UNITS ARE NON-RETURNABLE**

[ ] As drawn      [ ] As marked

Signed: \_\_\_\_\_ Date: \_\_\_\_\_

Printed Name: \_\_\_\_\_

**LEAD TIME WILL START UPON RECEIPT OF SIGNED APPROVAL DRAWING**

FOR INTERNAL USE ONLY PROJECT SIGN OFF	
SALES	
ENG.	
FAB.	
POWER	

DISTRIBUTOR'S NAME:		P.O.#
VESTIL MANUFACTURING		X
DRAWN BY:	DATE:	W.O.#
K.YEAKLE	05/09/12	X
REFERENCE:	SCALE:	SALES:
X	1:8	X
QUOTED LEAD TIME:	QUOTE #	FILE NAME:
X	X	29-007-040-001