

# TRUCK CRANE W/ MAGNET - WTJ-HITCH-ML-6

APPROX WEIGHT: 159.42 lbs.  
DOES NOT INCLUDE WEIGHT OF POWER OR PACKAGING!!!

\*\*\* ANY ADDITIONS, DELETIONS, OR OMISSIONS MUST BE CORRECTED ON THIS DRAWING AS THIS DRAWING WILL BE CONSIDERED ALL INCLUSIVE \*\*\*

ALL GRAPHICS PROVIDED ARE FOR REFERENCE ONLY. IF CERTAIN DIMENSIONS ARE CRITICAL PLEASE VERIFY THOSE DIMENSIONS WITH YOUR SALESPERSON

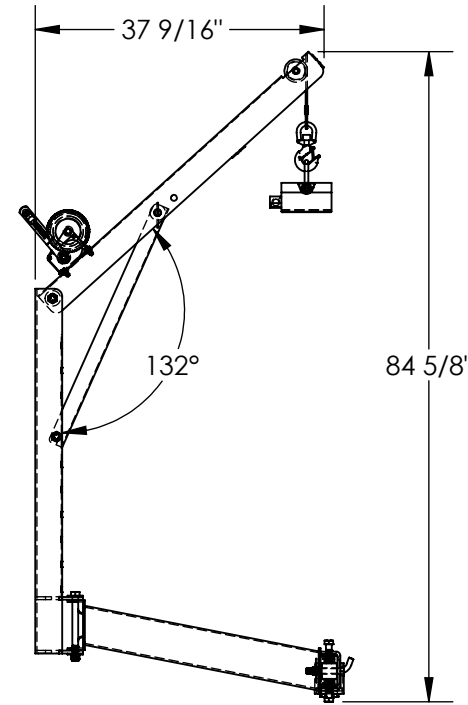
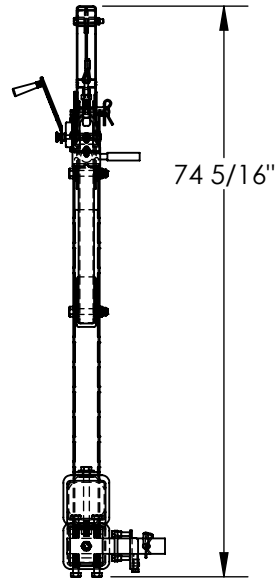
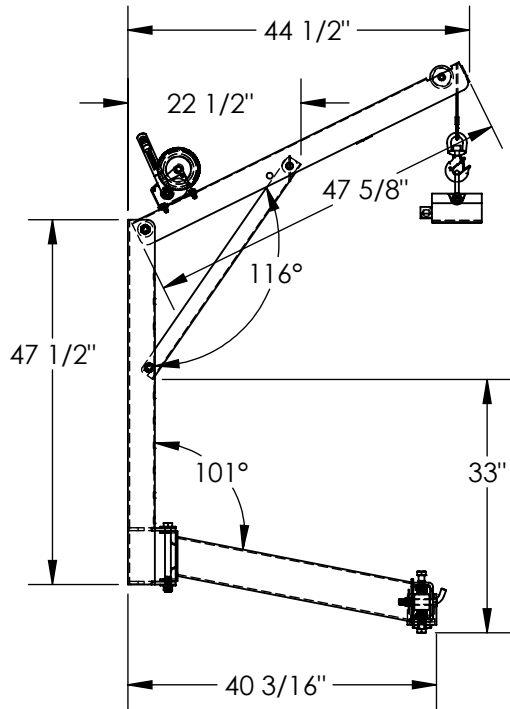

EXTENDED CLEARANCE POSITION

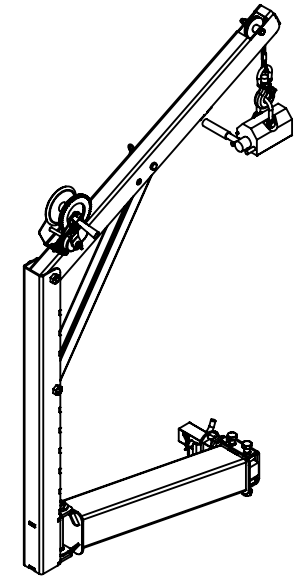

DIMENSION TOLERANCE ± 1/4"

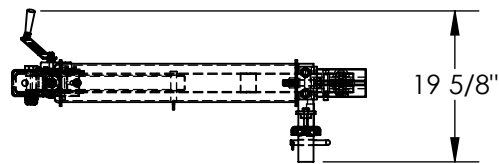

## STANDARD FEATURES

- MODEL NUMBER IS WTJ-HITCH-ML-6
- CAPACITY IS 600 LBS
- OVERALL WIDTH IS 19 13/16"
- OVERALL LENGTH IS 44 1/2"
- OVERALL HEIGHT IS 74 5/16"
- MAXIMUM HEIGHT IS 84 5/8"
- EASILY MOUNTS IN STANDARD CLASS III OR HIGHER 2" RECEIVER
- INSTALLATION & USE REQUIRES NO MODIFICATIONS TO TRUCK
- UNIT MAY BE ADJUSTED/LEVELED FOR BEST USE
- MANUAL HAND BRAKE WINCH AND LIFTING HOOK
- EXTENDED CABLE LENGTH IS 15 FT
- CRANE MAY BE INSTALLED ON EITHER SIDE OF TRUCK
- RUGGED WELDED STEEL CONSTRUCTION
- TOUGH BAKED IN POWDER-COATED BLACK FINISH

## SPECIAL FEATURES

NONE

APPROVAL

I, THE UNDERSIGNED, AGREE THAT THE PRODUCT AS REPRESENTED SATISFIES DESIGN AND DIMENSION REQUIREMENTS. I ALSO ACKNOWLEDGE MY DUTY TO CONFIRM PRODUCT AND INSTALLATION COMPLIANCE WITH ALL APPLICABLE FEDERAL, STATE AND LOCAL REGULATIONS AND STANDARDS.  
**UNITS REQUIRING APPROVAL DRAWINGS OR MODIFIED ARE NON-RETURNABLE**  
[ ] As drawn [ ] As marked

Signed: \_\_\_\_\_ Date: \_\_\_\_\_

Printed Name: \_\_\_\_\_

LEAD TIME WILL START UPON RECEIPT OF SIGNED APPROVAL DRAWING

DISTRIBUTOR'S NAME:		P.O.#
VESTIL MANUFACTURING		X
DRAWN BY:	DATE:	W.O.#
JWW	7/19/2023	X
REFERENCE:	SCALE:	SALES:
X	1:25	X
QUOTED LEAD TIME:	QUOTE #	FILE NAME:
X	X	28-007-500