

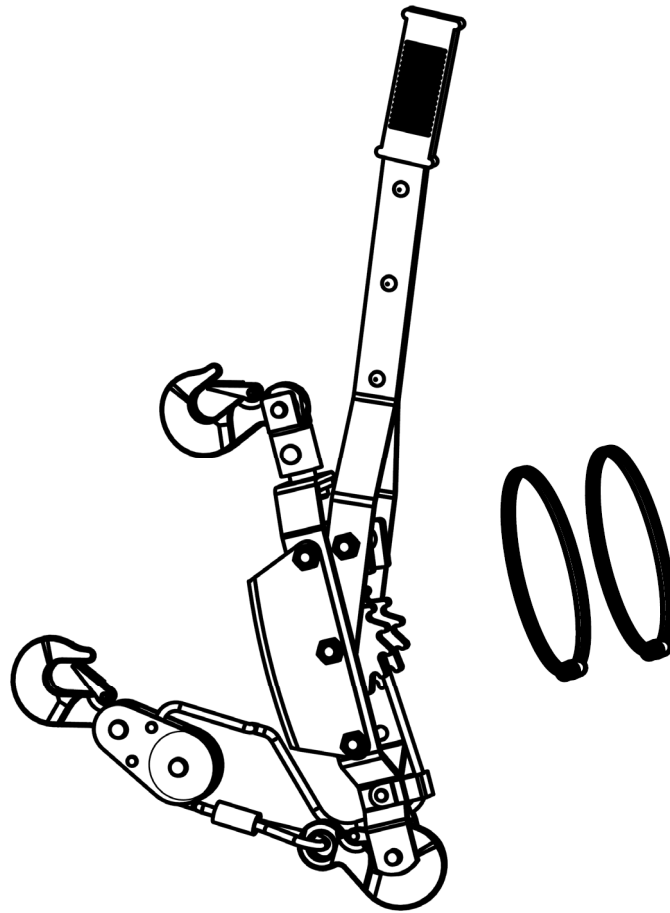

VESTIL MANUFACTURING CORP.

2999 North Wayne Street, P.O. Box 507, Angola, IN 46703
 Telephone: (260) 665-7586 -or- Toll Free (800) 348-0868
 Fax: (260) 665-1339
 www.vestilmfg.com e-mail: sales@vestil.com

AHA-KIT Height Adjustment Kit
 Instruction Manual



Receiving instructions:

After delivery, IMMEDIATELY remove the product from the packaging. Inspect it closely to determine whether it sustained damage during transport. If damage is discovered, immediately record a complete description of the damage on the bill of lading. If the product is undamaged, discard the packaging.

NOTES:

- 1) Compliance with laws, regulations, codes, and non-voluntary standards enforced in the location where the product is *used* is exclusively the responsibility of the owner/end-user.
- 2) VESTIL is not responsible for injury or property damage that results from a failure to apply: a) Instructions in this manual; or b) information provided on labels on the product.

Table of Contents

Signal Words.....	2
Hazards of Improper Use.....	2
Using the come-along.....	3-4
Inspections & Maintenance.....	4
Limited warranty.....	5

Signal Words:

This manual uses SIGNAL WORDS to indicate the likelihood of personal injuries, as well as the probable seriousness of those injuries, if the product is misused in the ways described. Other signal words call attention to uses of the product likely cause property damage. The signal words used appear below along with the meaning of each word.



Identifies a hazardous situation which, if not avoided, **WILL** result in **DEATH** or **SERIOUS INJURY**. Use of this signal word is limited to the most extreme situations.



Identifies a hazardous situation which, if not avoided, **COULD** result in **DEATH** or **SERIOUS INJURY**.



Indicates a hazardous situation which, if not avoided, **COULD** result in **MINOR** or **MODERATE** injury.



Identifies practices likely to result in product/property damage, such as operation that might damage the product.

Hazards of Improper Use:

Vestil strives to identify all hazards associated with the use of its products. However, material handling is inherently dangerous and no manual can address every conceivable risk.



Electrocution might result if any part of the crane, AHA-KIT, hoist or load contacts electrified wires. Reduce the likelihood of electrocution by applying **common sense**:

- DO NOT *contact* electrified wires with any part of the crane, kit, hoist or load;
- DO NOT perform height adjustments in a location where contact with electrified wires will occur or is likely to occur. Choose a location that has no overhead wiring.



Serious personal injury might result if this kit is used improperly:

- *Failure to read and understand the entire manual before installing, using or servicing the product constitutes misuse.*
- Read the manual whenever necessary to refresh your understanding of proper use and maintenance procedures.
- ONLY use the components of the come-along kit to adjust the height of AHA and AHS series gantry cranes. DO NOT use the kit as a hoist or winch.
- ONLY use this kit to adjust the height of an unloaded crane.
- Secure the hoist and trolley to the beam of your crane (or remove the hoist and trolley) before beginning the height adjustment to prevent the hoist from sliding back-and-forth on the beam during the adjustment.
- Inspect the cable pullers before each use according to the instructions on p. 4. DO NOT use a cable puller that is damaged and does not function normally. Immediately tag out the cable puller and replace each part that fails to pass an inspection. DO NOT use the product until it is fully restored to normal condition. ONLY use manufacturer-approved replacement parts.
- DO NOT use the product if any unusual noise or movement is observed. If a malfunction occurs, remove the unit from service and notify your supervisor or maintenance personnel about the issue.
- DO NOT use the come-along in place of the height adjustment pins. ONLY use this kit to adjust the height of your crane. Complete the height adjustment and reinsert both adjustment pins.
- DO NOT modify any part of the cable pullers in any way UNLESS you first obtain written approval from Vestil. Unauthorized modifications automatically void the limited warranty (see p. 5) and might make the AHS-KIT unsafe to use.



Proper use, maintenance, and storage are essential for this product to function properly.

- Always use this product in accordance with the instructions in this manual and consistent with any relevant training.
- Store the cable pullers someplace where it will remain dry.
- Periodically grease pivot points as needed to maintain smooth operation.

Using the kit:

The kit consists of 2 cable pullers—1 for each end of the crane—and 2 loops of cable.

FIG.1: Exploded parts diagram

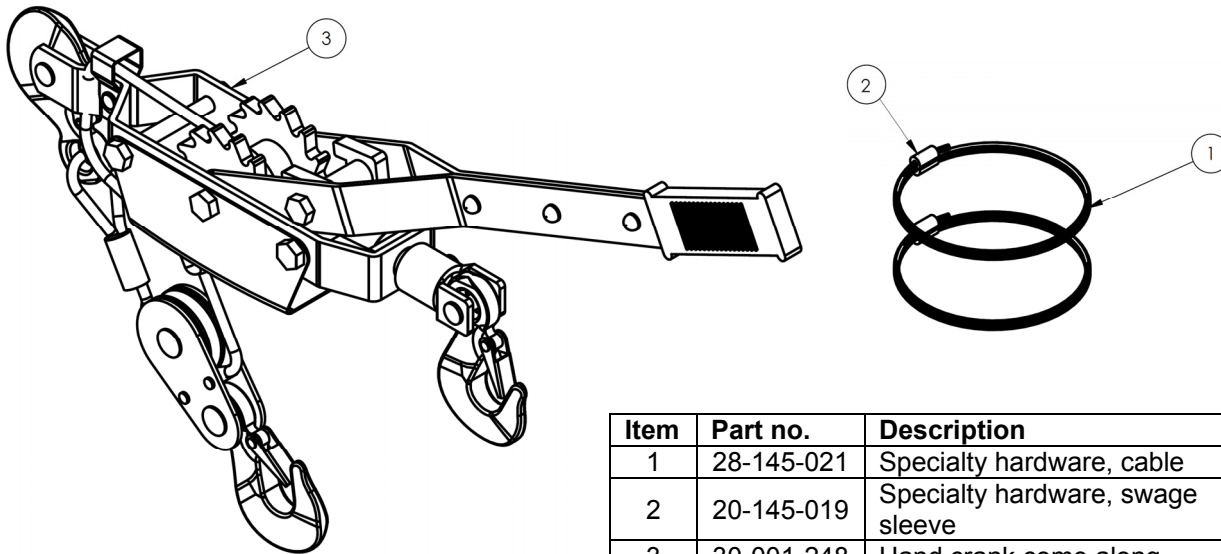

Item	Part no.	Description	Qty.
1	28-145-021	Specialty hardware, cable	2
2	20-145-019	Specialty hardware, swage sleeve	2
3	30-001-248	Hand crank come along	1

Use instructions: [NOTE: Immobilize your crane by locking the casters perpendicularly to each other.]

Step 1: Install the cable coils around each upright. Twist the cable loops into an “8” and fold the top of the 8 over onto the bottom part of the 8 (this will double loop the cable). Slide the doubled loop around the top of the yoke and insert an upright. Make sure that the coils are below the retaining pin and

Step 2: Attach the fixed hook (A) to the cable coils as shown in the diagram below.

Step 3: Attach the cable hook (B) to the bottom of the upright.

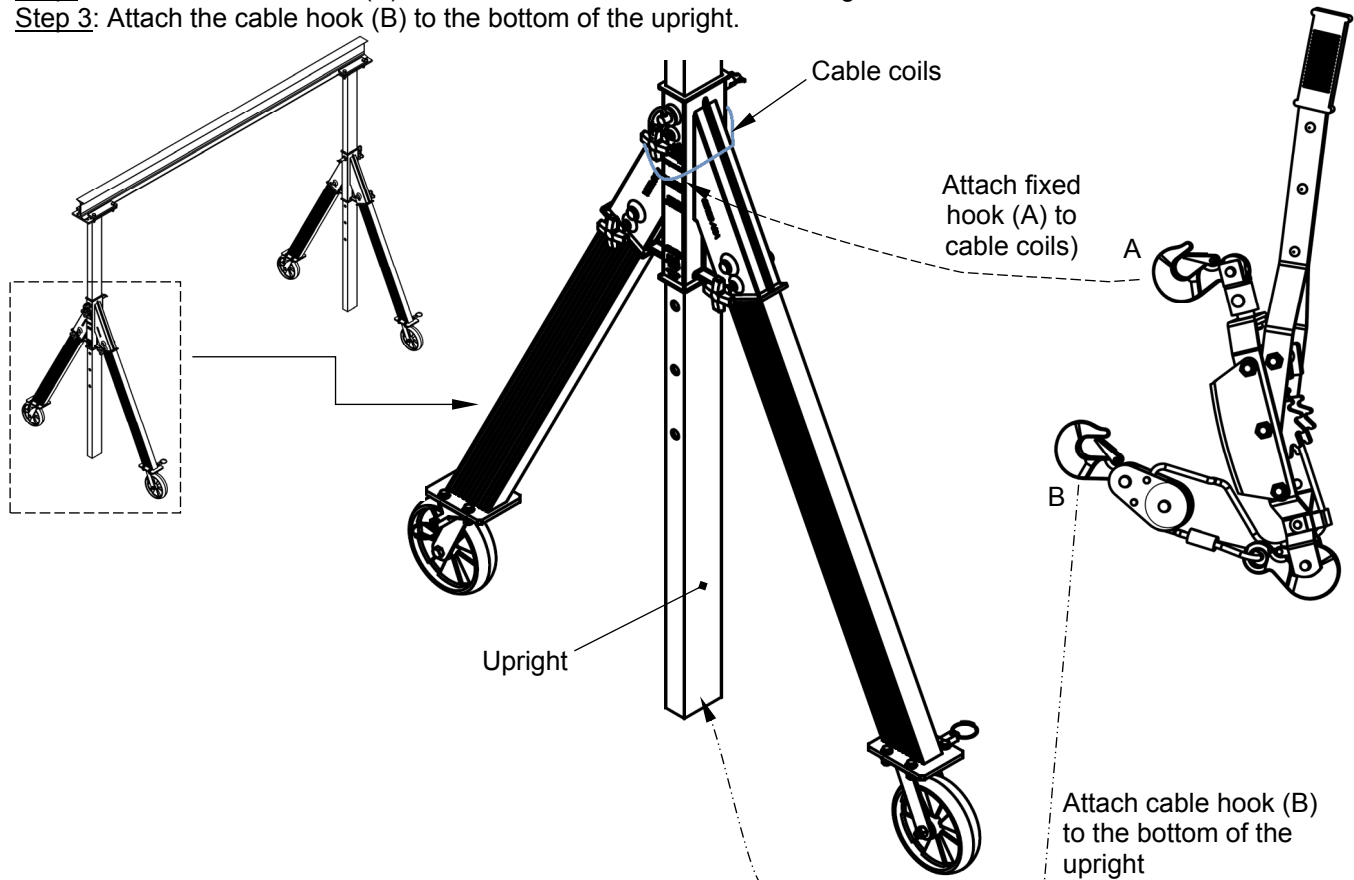

Step 4: The cable puller works in two directions: forward and reverse. In forward mode, moving the handle back-and-forth winds the cable onto the spool and draws the hook towards the puller. In reverse mode, moving the handle extends the cable.

Mode is controlled by the position of the direction control spring. The spring is shown in the REVERSE position. Slide the end of the spring along the slot to select between FORWARD and REVERSE modes.

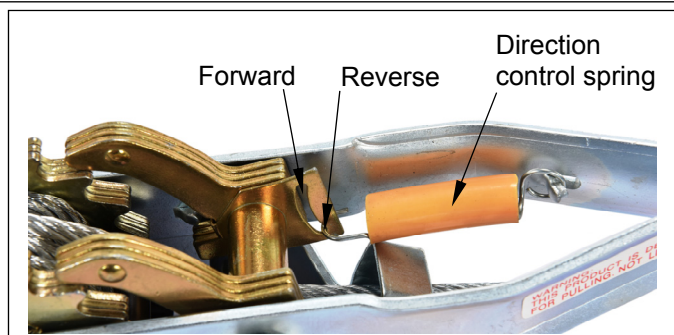

Step 4: To raise the uprights, put the cable pullers in FORWARD mode. Move the handles back-and-forth until the cables are taut. Remove the adjustment pins to allow the uprights to move. Continue to move the handle back-and-forth to raise the uprights.

Step 5: Reinsert the adjustment pins when height adjustment is complete. Put one cable puller in REVERSE mode and extend the cable until the cable hook can be disengaged from the bottom of the upright. Then, repeat the process with the other cable puller.

Inspections: Always inspect both of the cable pullers before using them. DO NOT use a cable puller unless it is in normal operating condition. If a problem is discovered during an inspection, correct the problem before using the puller. If a problem cannot be corrected, replace the damaged unit.

1. Check the soundness of all fastener connections (bolts, nuts, pins, rivets, etc.).
2. Inspect the hooks to confirm normal condition, motion, shape, and state of wear. If either hook is excessively worn or distorted, immediately tag it "OUT OF SERVICE". Replace the affected component before returning the puller to service.
3. Inspect the spool, ratchet mechanism, spring, and handle. Confirm that each part is undamaged (not bent or cracked) and in normal condition.
4. Extend the cable and inspect it. The cable should be free of frays, numerous broken outside strands, regions where the cable is noticeably narrower than the rest of the cable, internal or external corrosion, severe kinks, crushed regions, and cuts.
5. Tighten all cable fasteners.

LIMITED WARRANTY

Vestil Manufacturing Corporation (“Vestil”) warrants this product to be free of defects in material and workmanship during the warranty period. *Our warranty obligation is to provide a replacement for a defective original part if the part is covered by the warranty, after we receive a proper request from the warrantee (you) for warranty service.*

Who may request service?

Only a warrantee may request service. *You are a warrantee if* you purchased the product from Vestil or from an authorized distributor AND Vestil has been fully paid.

What is an “original part”?

An original part is a part used to make the product as shipped to the warrantee.

What is a “proper request”?

A request for warranty service is proper if Vestil receives: 1) a photocopy of the Customer Invoice that displays the shipping date; AND 2) a written request for warranty service including your name and phone number. Send requests by any of the following methods:

Mail
Vestil Manufacturing Corporation
2999 North Wayne Street, PO Box 507
Angola, IN 46703

Fax
(260) 665-1339
Phone
(260) 665-7586

Email
sales@vestil.com

In the written request, list the parts believed to be defective and include the address where replacements should be delivered.

What is covered under the warranty?

After Vestil receives your request for warranty service, an authorized representative will contact you to determine whether your claim is covered by the warranty. Before providing warranty service, Vestil may require you to send the entire product, or just the defective part or parts, to its facility in Angola, IN. The warranty covers defects in the following original dynamic components: motors, hydraulic pumps, electronic controllers, switches and cylinders. It also covers defects in original parts that wear under normal usage conditions (“wearing parts”), such as bearings, hoses, wheels, seals, brushes, and batteries.

How long is the warranty period?

The warranty period for original dynamic components is 90 days. For wearing parts, the warranty period is 90 days. The warranty periods begin on the date when Vestil ships the product to the warrantee. If the product was purchased from an authorized distributor, the periods begin when the distributor ships the product. Vestil may, at its sole discretion, extend the warranty periods for products shipped from authorized distributors by *up to* 30 days to account for shipping time.

If a defective part is covered by the warranty, what will Vestil do to correct the problem?

Vestil will provide an appropriate replacement for any *covered* part. An authorized representative of Vestil will contact you to discuss your claim.

What is not covered by the warranty?

1. Labor;
2. Freight;
3. Occurrence of any of the following, which automatically voids the warranty:
 - Product misuse;
 - Negligent operation or repair;
 - Corrosion or use in corrosive conditions;
 - Inadequate or improper maintenance;
 - Damage sustained during shipping;
 - Accidents involving the product;
 - Unauthorized modifications: DO NOT modify the product IN ANY WAY without first receiving written authorization from Vestil. Modification(s) might make the product unsafe to use or might cause excessive and/or abnormal wear.

Do any other warranties apply to the product?

Vestil Manufacturing Corp. makes no other express warranties. All implied warranties are disclaimed to the extent allowed by law. Any implied warranty not disclaimed is limited in scope to the terms of this Limited Warranty.

