



**Vestil Manufacturing Corp.**  
 2999 North Wayne Street, P.O. Box 507, Angola, IN 46703  
 Telephone: (260) 665-7586 -or- Toll Free (800) 348-0868  
 Fax: (260) 665-1339  
 Web: [www.vestilmfg.com](http://www.vestilmfg.com) e-mail: [info@vestil.com](mailto:info@vestil.com)

# BR-L2 & BL-L3 Series Bicycle Racks

## Instruction Manual



BR-L2

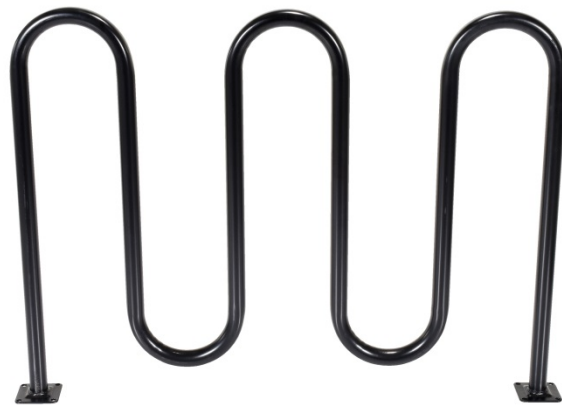

BR-L3

Receiving instructions

After delivery, remove the packaging from the product. Inspect the product closely to determine whether it sustained damage during transport. If damage is discovered, record a complete description of it on the bill of lading. If the product is undamaged, discard the packaging.

Replacement Parts and Technical Service

For answers to questions not addressed in these instructions and to order replacement parts, labels, and accessories, call our Technical Service and Parts Department at (260) 665-7586. The department can also be contacted online at [http://www.vestilmfg.com/parts\\_info.htm](http://www.vestilmfg.com/parts_info.htm).

NOTE: The end-user is solely responsible for confirming that product design, use, and maintenance comply with laws, regulations, codes, and mandatory standards applied where the product is used.

Table of Contents

Signal Words.....	2
Hazards.....	2
BR-L2 Dimensions and Bill of Materials.....	2
BR-L3 Dimensions and Bill of Materials.....	3
Record of Satisfactory Condition.....	3
Inspections and Maintenance.....	3
Labeling Diagram.....	3
Limited Warranty.....	4

## SIGNAL WORDS

This manual classifies personal injury risks and situations that might cause property damage with signal words. Signal words indicate the seriousness of injuries that might result if a particular act does, or does not, occur.



Identifies a hazardous situation which, if not avoided, **WILL** result in DEATH or SERIOUS INJURY. Use of this signal word is limited to the most extreme situations.



Identifies a hazardous situation which, if not avoided, **COULD** result in DEATH or SERIOUS INJURY.



Indicates a hazardous situation which, if not avoided, **COULD** result in MINOR or MODERATE injury.



Identifies practices likely to result in product/property damage, such as operation that might damage the product.

## HAZARDS

Vestil strives to identify all foreseeable hazards associated with the use of its products. However, no manual can address every possible risk. The most effective means for avoiding injury are to read all of the instructions before installing the rack and to apply sound judgement whenever using, inspecting, and maintaining it.



If this product is used improperly or carelessly, the operator and/or bystanders might sustain serious personal injuries or even be killed. **ALWAYS** use the product properly:

- **Read and understand the entire manual before assembling, installing, using or servicing the product.** Read the manual to refresh your understanding of proper use and maintenance procedures whenever necessary.
- Inspect the bicycle rack in accordance with the directions in the *Inspections & Maintenance* section. Remove the rack from service if it is not in *Satisfactory Condition*.
- DO NOT use the rack UNLESS it is securely anchored to the ground.
- DO NOT remove or obscure any label. All labels must be readable. See *Labeling Diagram* on p. 3.
- DO NOT modify the bicycle rack in any way. **Unauthorized modifications automatically void the Limited Warranty on p. 4 and might make the rack unsafe to use.**

## BR-L2 DIMENSIONS AND BILL OF MATERIALS

Fasten the rack to the ground using  $\frac{5}{8}$ " anchor bolts of appropriate length, i.e. selected by your building/facility engineer. Install the bolts through the 4 bolt holes in each foot pad.

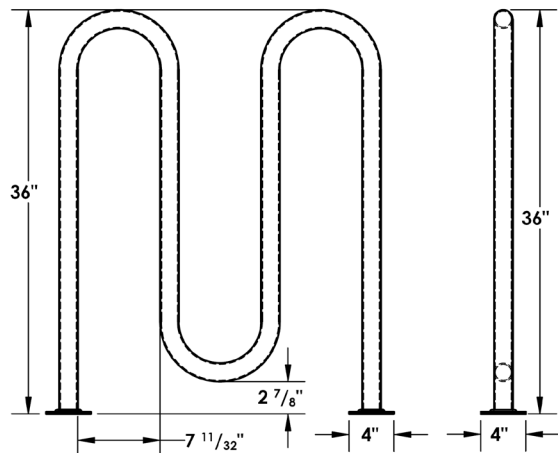
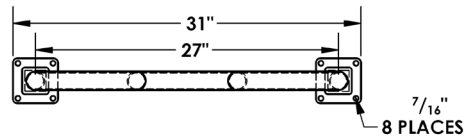
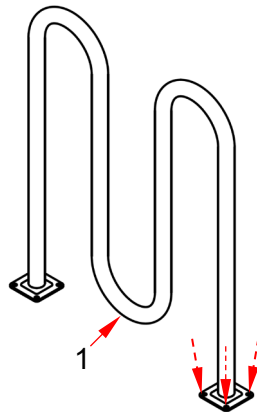

Item	Part no.	Description	Qty.
1	31-516-230 31-516-232	Bicycle rack frame weldment: BR-L2-BK (Black) BR-L2-GAL (Galvanized)	1

## BR-L3 DIMENSIONS AND BILL OF MATERIALS

Fasten the rack to the ground using  $\frac{5}{8}$ " anchor bolts of appropriate length, i.e. selected by your building/facility engineer. Install the bolts through the 4 bolt holes in each foot pad.

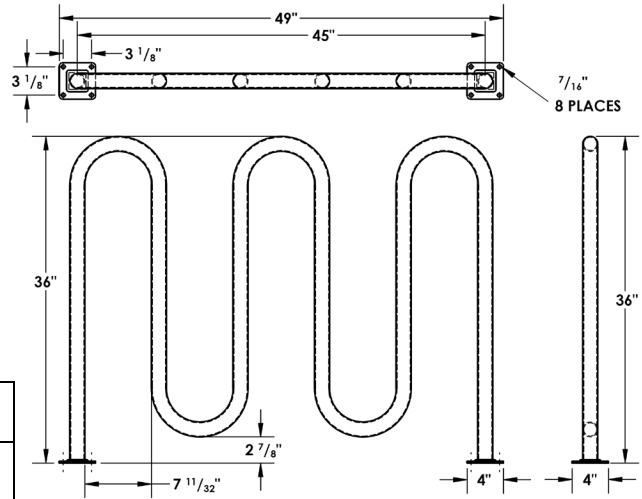
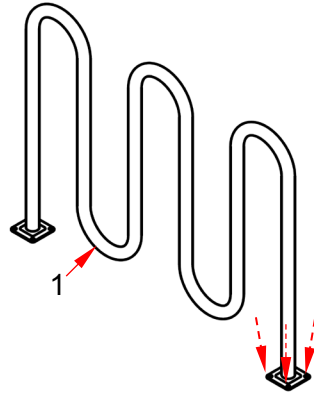

Item	Part no.	Description	Qty.
1	31-514-231 31-516-233	Bicycle rack frame weldment: BR-L3-BK (Black) BR-L3-GAL (Galvanized)	1

## RECORD OF SATISFACTORY CONDITION (THE "RECORD")

Record the condition of the rack before putting it into service. Thoroughly photograph the unit from multiple angles. Take close range photographs of all labeling and anchoring points. Collate all photographs and writings into a file. Mark the file appropriately to identify it. This file is a record of the rack in satisfactory condition. Compare the results of each inspection to this record to determine whether the rack is in satisfactory condition. Purely cosmetic changes, like damaged surface finish (paint or powdercoat), are not changes from satisfactory condition. However, touchup paint should be applied to all affected areas as soon as damage occurs.

## INSPECTIONS & MAINTENANCE

At least once per month, thoroughly inspect the unit. Compare the condition of the rack to the *RECORD*. Replace the rack if it is not in satisfactory condition.

- Examine the rack/frame for cracked welds and severe rust/corrosion.
- Closely inspect the anchor bolts and the ground around the anchor bolts. The rack should be firmly anchored to the ground. If the rack wobbles, tighten the anchor bolts. If the bolts cannot be tightened, install the rack in another location.

## LABELING DIAGRAM

The unit should be labeled as shown in the diagram. However, label content and location are subject to change so your product might not be labeled exactly as shown. Thoroughly photograph the unit when you first receive it as discussed in the *Record of Satisfactory Condition* section of this manual. Make sure that your Record includes a photograph of each label. Modify this diagram, if necessary, to indicate labeling actually applied. Replace all labels that are, damaged, missing, or not easily readable (e.g. faded). Contact the *Parts Department* online at [http://www.vestilmfg.com/parts\\_info.htm](http://www.vestilmfg.com/parts_info.htm) to order replacement labels. You may also call (260) 665-7586 and ask the operator to connect you to the *Parts Department*.



### A: Label 287

MODEL/MODÉLO/MODÈLE	_____
STATIC CAPACITY (evenly distributed)	_____ lbs.
LA CAPACIDAD CONSTANTE (distribuida uniformemente)	_____ kgs.
CAPACITÉ STATIQUE (distribuée régulièrement)	_____ kgs.
SERIAL/SÉRIE/SÉRIE	_____

287 REV 0812

### B: Label 204

<b>▲ WARNING ▲ ADVERTENCIA ▲ AVERTISSEMENT</b>		
SECURE FRAME TO FLOOR	ASEGURE EL BASTIDOR AL PISO	FIXER SOLIDEMENT LE CADRE AU PLANCHER

## LIMITED WARRANTY

Vestil Manufacturing Corporation (“Vestil”) warrants this product to be free of defects in material and workmanship during the warranty period. Our warranty obligation is to provide a replacement for a defective, original part covered by the warranty after we receive a proper request from the Warrantee (you) for warranty service.

### Who may request service?

Only a warrantee may request service. You are a warrantee if you purchased the product from Vestil or from an authorized distributor AND Vestil has been fully paid.

### Definition of “original part”?

An original part is a part used to make the product received by the Warrantee.

### What is a “proper request”?

A request for warranty service is proper if Vestil receives: 1) a photocopy of the Customer Invoice that displays the shipping date; AND 2) a written request for warranty service including your name and phone number. Send requests by one of the following methods:

<u>US Mail</u>	<u>Fax</u>	<u>Email</u>
Vestil Manufacturing Corporation 2999 North Wayne Street, PO Box 507 Angola, IN 46703	(260) 665-1339 <u>Phone</u> (260) 665-7586	<a href="mailto:info@vestil.com">info@vestil.com</a> Enter “Warranty service request” in subject field.

In the written request, list the parts believed to be defective and include the address where replacements should be delivered. After Vestil receives your request for warranty service, an authorized representative will contact you to determine whether your claim is covered by the warranty. Before providing warranty service, Vestil will require you to send the entire product, or just the defective part (or parts), to its facility in Angola, IN.

### What is covered under the warranty?

The warranty covers defects in the following original, dynamic parts: motors, hydraulic pumps, motor controllers, and cylinders. It also covers defects in original parts that wear under normal usage conditions (“wearing parts”), such as bearings, hoses, wheels, seals, brushes, and batteries.

### How long is the warranty period?

The warranty period for original dynamic components is 90 days. For wearing parts, the warranty period is 90 days. Both warranty periods begin on the date Vestil ships the product to the Warrantee. If the product was purchased from an authorized distributor, the periods begin when the distributor ships the product. Vestil may, at its sole discretion, extend a warranty period for products shipped from authorized distributors by up to 30 days to account for shipping time.

### If a defective part is covered by the warranty, what will Vestil do to correct the problem?

Vestil will provide an appropriate replacement for any *covered* part. An authorized representative of Vestil will contact you to discuss your claim.

### What is not covered by the warranty?

The Warrantee (you) is responsible for paying labor costs and freight costs to return the product to Vestil for warranty service.

### Events that automatically void this Limited Warranty.

- Misuse;
- Negligent assembly, installation, operation or repair;
- Installation/use in corrosive environments;
- Inadequate or improper maintenance;
- Damage sustained during shipping;
- Collisions or other accidents that damage the product;
- Unauthorized modifications: Do not modify the product IN ANY WAY without first receiving written authorization from Vestil.

### Do any other warranties apply to the product?

Vestil Manufacturing Corp. makes no other express warranties. All implied warranties are disclaimed to the extent allowed by law. Any implied warranty not disclaimed is limited in scope to the terms of this Limited Warranty. Vestil makes no warranty or representation that this product complies with any state or local design, performance, or safety code or standard. Noncompliance with any such code or standard is not a defect in material or workmanship.

