

T & S EQUIPMENT COMPANY
 2999 North Wayne St., Angola, IN 46703 USA
 Ph: 219-665-9521 Fax 219-665-1339
 E-mail: sales@tseq.com Website: www.tseq.com

Revised 05-01

A company dedicated to solving ergonomic and material handling problems since 1955.

OWNERS MANUAL

**ALUMINUM CONVERTIBLE HAND TRUCK
MODEL CAHT-500**

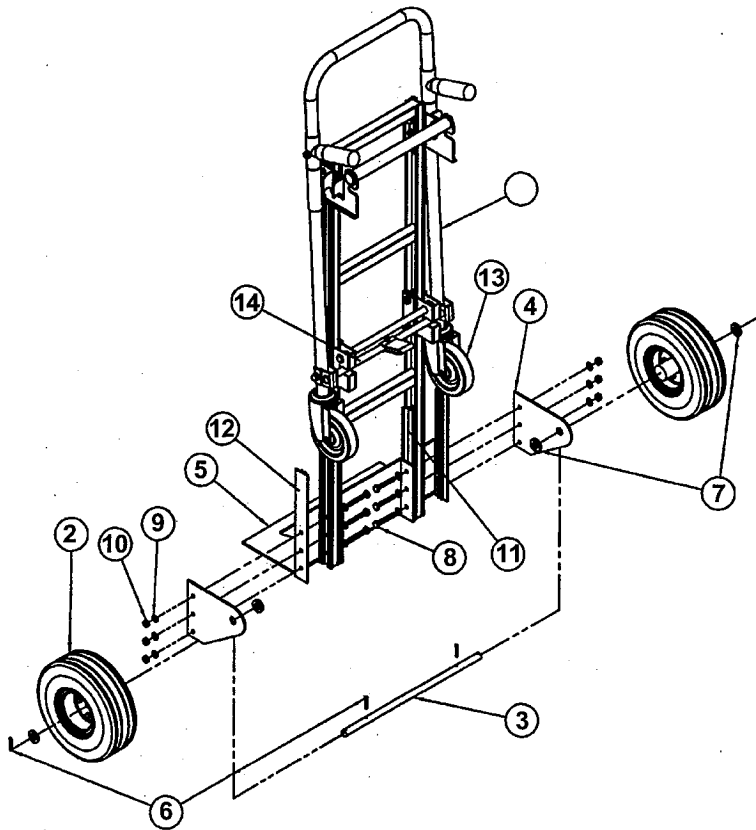
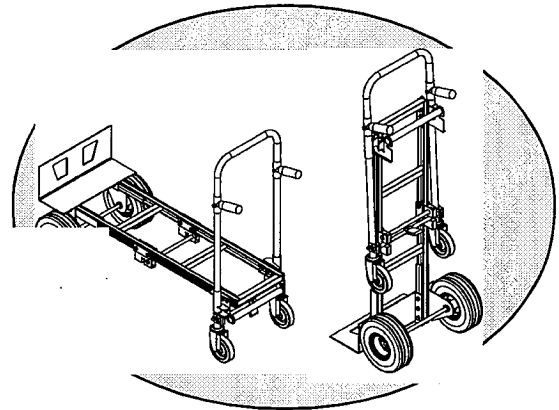

**500 lb.
CAPACITY**

ITEM NO.	DESCRIPTION	PART NO.	QTY.
1	Main Body	CAHT-1	1
2	Pneumatic, Tires 10 x 3-1/4	CAHT-2	2
3	Axle - 5/8 x 17-1/2	CAHT-3	1
4	Axle Bracket	CAHT-4	2
5	Platform	CAHT-5	1
6	Cotter Keys 1/8"	CAHT-6	4
7	Spacer M-16	CAHT-7	4
8	Bolts M8 x 1.25 x 55	CAHT-8	6
9	Washers M8	CAHT-9	6
10	Lock Nut M8 x 1.25	CAHT-10	6
11	Inner Brace	CAHT-11	2
12	Outer Brace	CAHT-12	2
13	Swivel Casters	CAHT-13	2
14	Latch Assembly	CAHT-14	1

RECEIVING INSTRUCTIONS

Every unit is thoroughly tested and inspected prior to shipment. However, it is possible that the unit may incur damage during transit. If damage is noticed when unloading, make a note of it on the **BILL OF LADING**. Remove all packing and strapping material, then inspect the unit again for damage. **IF DAMAGE IS EVIDENT, FILE A CLAIM WITH THE CARRIER IMMEDIATELY!**

WARRANTY

This product is warranted for 90 DAYS from date of purchase to be free of manufacturing defects in material and workmanship. The manufacturer's obligation hereunder is limited to repairing such products during the warranty period, provided the product is sent prepaid back to the factory.

This warranty does not cover normal wear of parts or damage resulting from any of the following: negligent use or misuse of the product, use or application contrary to installation instructions, or disassembly, repair or alteration by any person prior to authorization from a factory representative.

Material Handling Problem Solvers

Time is money. Increased productivity equals greater profitability, cost minimization and worker compatibility. Ergonomic products will assist you with your production and safety goals.

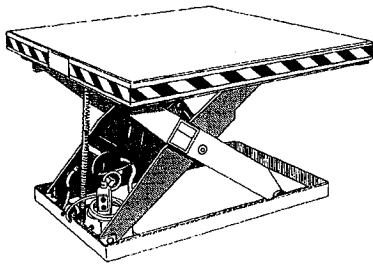

**ELECTRIC HYDRAULIC
SCISSOR LIFT TABLE**

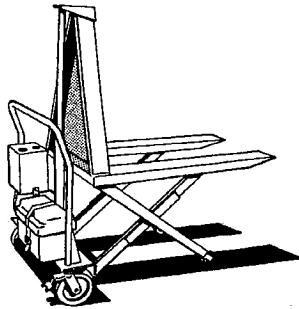

**HIGH RISE
LIFT TRUCK**

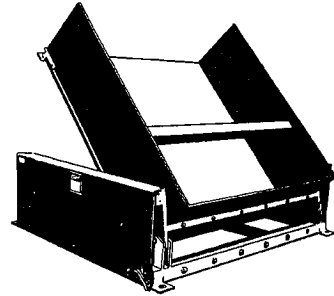

GROUND TILTER

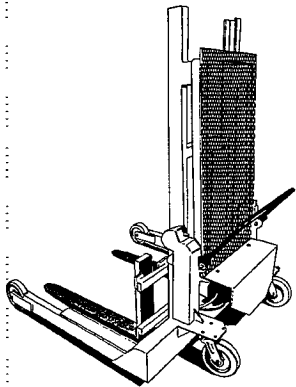

**DC POWERED
PALLET MASTER/SERVER**

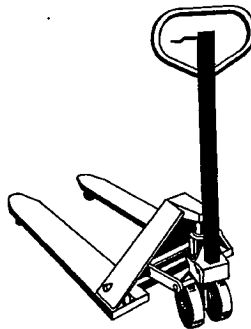

**DELUXE
PALLET TRUCK**

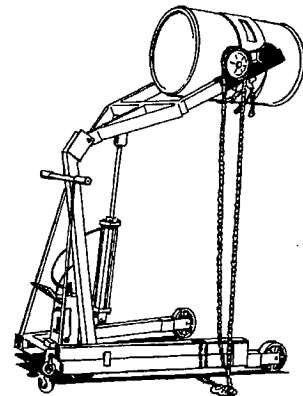

**HYDRAULIC DRUM
CARRIER/ROTATOR**