



Vestil Manufacturing Corp.

2999 North Wayne Street, P.O. Box 507, Angola, IN 46703

Telephone: (260) 665-7586 -or- Toll Free (800) 348-0868

Fax: (260) 665-1339

Web: www.vestilmfg.com e-mail: sales@vestil.com

**CARPET-45 CARPET TRUCK
INSTRUCTION MANUAL**



Receiving instructions

After delivery, remove the packaging from the product. Inspect the product closely to determine whether it sustained damage during transport. If damage is discovered, record a complete description of it on the bill of lading. If the product is undamaged, discard the packaging.

Replacement Parts and Technical Service

For answers to questions not addressed in these instructions and to order replacement parts, labels, and accessories, call our Technical Service and Parts Department at (260) 665-7586. The department can also be contacted online at http://www.vestilmfg.com/parts_info.htm.

NOTE: The end-user is solely responsible for confirming that product design, use, and maintenance comply with laws, regulations, codes, and mandatory standards applied where the product is used.

Table of Contents

Signal Words.....	2
Specifications.....	2
Hazards.....	2
Exploded View and Bill of Materials.....	3
Assembly.....	3
Using the Carpet Truck.....	4
Record of Satisfactory Condition.....	4
Inspections & Maintenance.....	4
Labeling Diagram.....	4
Limited Warranty.....	5

SIGNAL WORDS

This manual classifies personal injury risks and situations that might cause property damage with signal words. Signal words indicate the seriousness of injuries that might result if a particular act does, or does not, occur.

DANGER Identifies a hazardous situation which, if not avoided, WILL result in DEATH or SERIOUS INJURY. Use of this signal word is limited to the most extreme situations.

WARNING Identifies a hazardous situation which, if not avoided, COULD result in DEATH or SERIOUS INJURY.

CAUTION Indicates a hazardous situation which, if not avoided, COULD result in MINOR or MODERATE injury.

NOTICE Identifies practices likely to result in product/property damage, such as operation that might damage the product.

SPECIFICATIONS

Dimensions, net weight, and capacity figures are provided in the following diagrams and table.

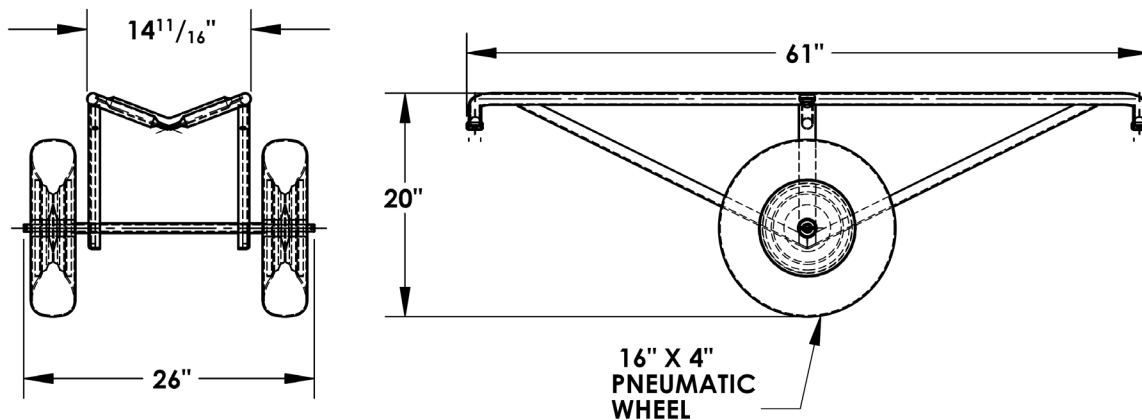

Model	Net Weight	Capacity
CARPET-45	34 lb. (15.5kg)	500 lb. (227.3kg)
CARPET-45-FF	44 lb. (20kg)	500 lb. (227.3kg)

HAZARDS

Vestil strives to identify all foreseeable hazards associated with the use of its products. However, no manual can address every possible risk. The most effective means for avoiding injury is to read all of the instructions prior to putting the dumper into service and to apply sound judgment whenever using this device.

WARNING *Read and understand the entire manual before assembling, using or servicing the carpet truck.*

Improper or careless use of this product could result in death or serious personal injury.

- DO NOT modify the product in any way UNLESS you first obtain written approval from Vestil. Unapproved modifications **automatically void the Limited Warranty and might make the product unsafe to use.**
- DO NOT apply loads to the truck that exceed its capacity. Center carpet rolls on the truck, i.e. above the axle.
- DO NOT stand, sit, or ride on the truck.
- Do not traverse uneven ground when the truck is loaded unless you can easily control it. Control the truck from the uphill side while moving up or down slopes.
- Ask someone to help you if you cannot easily control the cart when it is loaded.

NOTICE Proper use, maintenance, and storage are essential for this product to function properly.

- Inspect and maintain the unit as directed in [Inspections & Maintenance](#).
- Units equipped with pneumatic tires: Check tire inflation. Air pressure should equal the recommended inflation pressure that appears on the sidewalls of the tires.

EXPLODED VIEW AND BILL OF MATERIALS

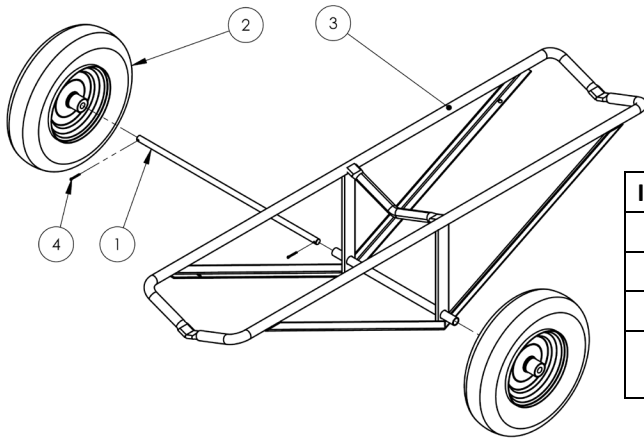

Item	Part no.	Description	Qty.
1	33-112-036	Axle, $\frac{5}{8}$ " x 26"	1
2	16-132-126	Pneumatic tire	2
3	33-514-129	Weldment, frame	1
4	65077	Cotter pin, zinc-plated, $\frac{1}{8}$ " x $1\frac{1}{4}$ "	2

ASSEMBLY

1) Insert the axle into the axle receiver. The axle is longer than the receiver and will stick out of both sides of the receiver.

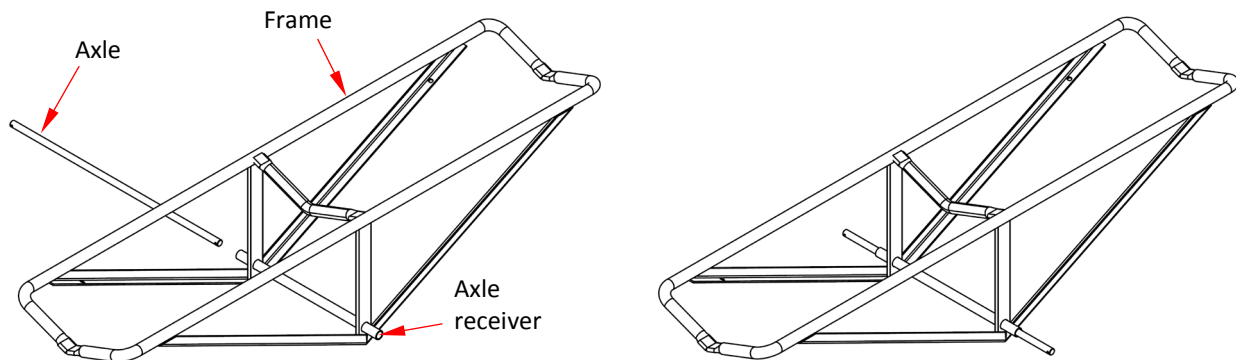

2) Slide a wheel onto each end of the axle. Make sure that the wheels are oriented with the valve stems facing outwards, i.e. away from the cart.

NOTE: Foam filled wheels (CART-45-FF) do not require inflation.

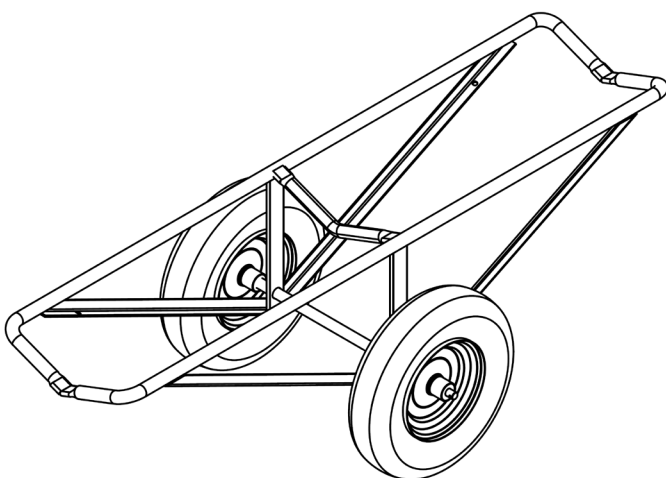

3) Press a cotter pin through the pin hole at each end of the axle. Then, bend the arms of the cotter pins in opposite directions around the axle.

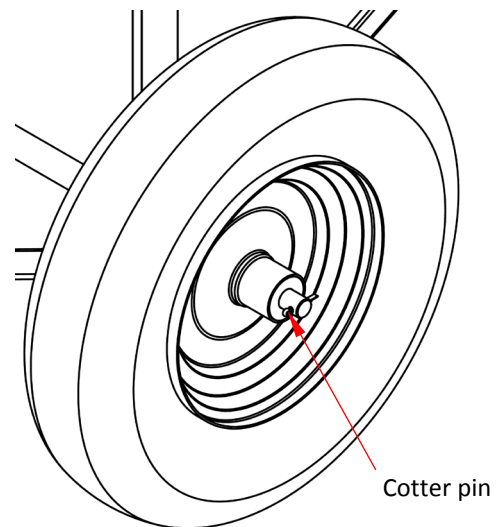

USING THE CARPET TRUCK

Center the roll of carpet on the truck. Do not load the truck beyond its capacity (500 pounds; 227.3kg). If a carpet roll weighs more than 500 pounds, use another device to move it. Grasp an end of the roll and carefully push the truck. Do not traverse sloped ground with a loaded truck unless you can easily control it. Always remain uphill from the truck. If you cannot push or control the truck when it is loaded, enlist a coworker to assist you. Both persons should grasp the same end of the roll and push the truck wherever needed.

Center the roll on the truck

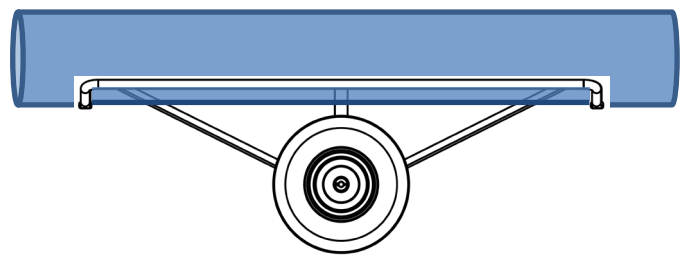

RECORD OF SATISFACTORY CONDITION (THE “RECORD”)

Record the condition of the truck before putting it into service. Thoroughly photograph the unit from multiple angles so that all welds are clearly visible. Take a close range photograph of each label. Use the truck to transport a roll of carpet. Describe how the truck reacts to the load. How much do the tires compress? What sounds do you hear as the wheels rotate? Collate the photographs and writings into a single file. Mark the file appropriately to identify it. This file is a record of the carpet truck in satisfactory condition. Compare the results of each inspection to this record to determine whether the truck is in satisfactory condition. Purely cosmetic changes, like damaged surface coating (paint or powdercoat), are not changes from satisfactory condition. However, touchup paint should be applied to all areas as soon as damage occurs.

INSPECTIONS & MAINTENANCE

At least once per month, thoroughly inspect the unit. Compare the condition of each component to the *RECORD*. Repair or replace all components that are not in satisfactory condition.

Wheels: Examine the wheels for cracks, cuts, bulges, and significant tread wear. Recommended tire inflation pressures are provided on the sided wall of both tires. Determine whether each tire should be inflated. Add air, if necessary, but do not overinflate the tires. Make sure that both cotter pins are in place. The arms of the pins should be bent in opposite directions around the axle. Push the (unloaded) truck. Make sure that it does not wobble. It should roll smoothly and easily. Apply lubricant between the wheel hubs and axle

Frame: Check all welds for cracks. Inspect the frame members for damage, such as warps, cracks, and thinned regions. Apply touchup paint wherever the finish is damaged.

LABELING DIAGRAM

The unit should be labeled as shown in the diagram. However, label content and location are subject to change so your product might not be labeled exactly as shown. Thoroughly photograph the unit when you first receive it as discussed in the *Record of Satisfactory Condition* section. Make sure that your record includes a photograph of each label. Replace all labels that are, damaged, missing, or not easily readable (e.g. faded). Contact the *Parts Department* online at http://www.vestilmfg.com/parts_info.htm to order replacement labels. You may also call (260) 665-7586 and ask the operator to connect you to the *Parts Department*.

Label 287

MODEL/MODELO/MODÈLE _____	
STATIC CAPACITY (evenly distributed) _____	lbs.
LA CAPACIDAD CONSTANTE (distribuida uniformemente) _____	kgs.
CAPACITÉ STATIQUE (distribuée régulièrement) _____	kgs.
SERIAL/SERIE/SÉRIE _____	
287 REV 08/12	

Label 375

⚠ WARNING ⚠ ADVERTENCIA ⚠ AVERTISSEMENT		
DO NOT PLAY ON OR AROUND	NO JUEGE ALREDEDOR	NE PAS JOUER SUR OU AUTOUR DE L'UNITÉ

Label 779

⚠ WARNING	⚠ ADVERTENCIA
<ul style="list-style-type: none"> • DO NOT load beyond rated capacity. • Center load over wheels. • Chock wheels when necessary. With Roller Option <ul style="list-style-type: none"> • Keep clear of rollers; rollers do not lock. • Lock stabilizer stands down before unrolling product. 	<ul style="list-style-type: none"> • No cargue mas de la capacidad tasada • Centre la carga sobre las ruedas. • Calce las ruedas cuando sea necesario. Con la opcion de rueda <ul style="list-style-type: none"> • Manténgase alejado de las ruedas, las ruedas no se bloquean. • Bloquee el estabilizador de pie antes de desenrollar el producto.



LIMITED WARRANTY

Vestil Manufacturing Corporation (“Vestil”) warrants this product to be free of defects in material and workmanship during the warranty period. Our warranty obligation is to provide a replacement for a defective, original part covered by the warranty after we receive a proper request from the Warrantee (you) for warranty service.

Who may request service?

Only a warrantee may request service. You are a warrantee if you purchased the product from Vestil or from an authorized distributor AND Vestil has been fully paid.

Definition of “original part”?

An original part is a part used to make the product as shipped to the Warrantee.

What is a “proper request”?

A request for warranty service is proper if Vestil receives: 1) a photocopy of the Customer Invoice that displays the shipping date; AND 2) a written request for warranty service including your name and phone number. Send requests by one of the following methods:

US Mail

Vestil Manufacturing Corporation
2999 North Wayne Street, PO Box 507
Angola, IN 46703

Fax

(260) 665-1339
Phone
(260) 665-7586

Email

info@vestil.com
Enter “Warranty service request”
in the subject field.

In the written request, list the parts believed to be defective and include the address where replacements should be delivered. After Vestil receives your request for warranty service, an authorized representative will contact you to determine whether your claim is covered by the warranty. Before providing warranty service, Vestil will require you to send the entire product, or just the defective part (or parts), to its facility in Angola, IN.

What is covered under the warranty?

The warranty covers defects in the following original, dynamic parts: motors, hydraulic pumps, motor controllers, and cylinders. It also covers defects in original parts that wear under normal usage conditions (“wearing parts”), such as bearings, hoses, wheels, seals, brushes, and batteries.

How long is the warranty period?

The warranty period for original dynamic components is 30 days. For wearing parts, the warranty period is 30 days. Both warranty periods begin on the date Vestil ships the product to the Warrantee. If the product was purchased from an authorized distributor, the periods begin when the distributor ships the product. Vestil may, at its sole discretion, extend a warranty period for products shipped from authorized distributors by up to 30 days to account for shipping time.

If a defective part is covered by the warranty, what will Vestil do to correct the problem?

Vestil will provide an appropriate replacement for any *covered* part. An authorized representative of Vestil will contact you to discuss your claim.

What is not covered by the warranty?

The Warrantee (you) is responsible for paying labor costs and freight costs to return the product to Vestil for warranty service.

Events that automatically void this Limited Warranty.

- Misuse;
- Negligent assembly, installation, operation or repair;
- Installation/use in corrosive environments;
- Inadequate or improper maintenance;
- Damage sustained during shipping;
- Collisions or other accidents that damage the product;
- Unauthorized modifications: Do not modify the product IN ANY WAY without first receiving written authorization from Vestil.

Do any other warranties apply to the product?

Vestil Manufacturing Corp. makes no other express warranties. All implied warranties are disclaimed to the extent allowed by law. Any implied warranty not disclaimed is limited in scope to the terms of this Limited Warranty. Vestil makes no warranty or representation that this product complies with any state or local design, performance, or safety code or standard. Noncompliance with any such code or standard is not a defect in material or workmanship.

