



INSTRUCTION MANUAL
DC POWERED HYDRAULIC ELEVATING CART
MODEL CART-DS-1000 (DC)



MODEL NO. _____
SERIAL NO. _____

VESTIL MANUFACTURING CORP.

2999 NORTH WAYNE STREET, P.O. BOX 507, ANGOLA, IN 46703
TELEPHONE: (260) 665-7586 -OR- TOLL FREE (800) 348-0868
FAX: (260) 665-1339

URL: WWW.VESTILMFG.COM EMAIL: SALES@VESTIL.COM



We produce several DC-powered hydraulic elevating cart models so that our customers may select a product that satisfies specific requirements. Each unit conforms to the generalized specifications disclosed in this manual and fulfills our demanding standards for quality, safety and durability.

SAFETY PRINCIPLES

Vestil Manufacturing Corp. recognizes the critical importance of workplace safety. Each person who **might** participate in the assembly, use, operation, or maintenance of the product must read this manual. **Read the entire manual and fully understand the directions BEFORE using or maintaining the cart. If you do not understand an instruction, contact Vestil for clarification. Failure to adhere to the directions in this manual constitutes misuse of the cart and might lead to serious personal injury or even death.**

Vestil is **not liable** for any injury or property damage that occurs as a consequence of failing to apply the safe operation and maintenance procedures explained in this manual or that appear on labels affixed to the product. Failure to exercise good judgment and common sense may result in property damage, serious personal injury, or death, and also are **not the responsibility of Vestil.**

This manual applies the hazard identification methods suggested for instruction manuals by the American National Standards Institute (ANSI) in ANSI standard Z535.6-2006. In accordance with ANSI guidelines for hazard warning language, this manual identifies personal injury risks and situations that could lead to property damage with SIGNAL WORDS. These signal words announce an associated safety message. The reader must understand that the signal word chosen to identify a particular safety hazard categorizes the seriousness of that hazard according to the following convention:

These symbols identify hazards that may result in personal injury

DANGER

Identifies a hazardous situation which, if not avoided, **WILL** result in **DEATH** or **SERIOUS INJURY**. Use of this signal word is limited to the most extreme situations.

WARNING

Identifies a hazardous situation which, if not avoided, **COULD** result in **DEATH** or **SERIOUS INJURY**.

CAUTION

Indicates a hazardous situation which, if not avoided, **COULD** result in **MINOR** or **MODERATE** injury. Although Z535.6-2006 approves the use of "CAUTION" without an accompanying safety alert symbol (black equilateral triangle with yellow exclamation point) as an alternative to "NOTICE", this manual differentiates between hazards that pose a risk of personal injury and those that create mere property damage situations. In this manual, "**CAUTION**" appears exclusively in conjunction with the safety alert symbol to identify injury risks.

NOTICE

Identifies practices not related to personal injury, such as operation that could damage the cart. No safety alert symbol (equilateral triangle enclosing an exclamation point) accompanies this signal word.

TABLE OF CONTENTS

	<u>PAGE</u>
Safety Principles	2
Product Introduction	4
Safety Guidelines	4
Parts List	5
Use Instructions	10-13
Loading	10
Lift Table Operation	11
Battery Charger	11-12
Hydraulic System Operation	12-13
Maintenance & Inspections	13
Troubleshooting	14

TABLE OF FIGURES

FIG. 1:	Labeled Photograph	5
FIG. 2A:	DC Modular Power Unit Electrical Components	6
FIG. 2B:	DC Modular Power Unit Hydraulic Components	7
FIG. 3:	Electrical Diagram	8
FIG. 4:	Hydraulic Diagram	9
FIG. 5A:	Proper Load Positioning (Side View)	10
FIG. 5B:	Proper Load Positioning (Top View)	10
FIG. 6:	Label Placement	15

PRODUCT INTRODUCTION



Thank you for purchasing a DC-powered hydraulic elevating cart (“cart,” “scissor lift cart,” “product,” “unit,” or simply referenced by model number) made by Vestil Manufacturing Corporation (“Vestil”). Our carts are durable, high-quality products that combine safety features and reliable, durable mechanisms. Despite the product’s relatively simple mechanics, all personnel must familiarize themselves with the safe operation instructions provided in this manual.

Specifications for the CART-DS-1000 appear in the table below:

	Net Wt. (lbs.)	Platform Size (W x L)	Vertical Range of Motion (in.)	Capacity (lbs.)
CART-DS-1000	370	20” x 33”	14” x 40”	1,000

Vestil Manufacturing Corp. created this manual to acquaint owners and users of our carts with safe use and maintenance procedures. **Employers are responsible for instructing employees to use the product properly. Employees and any other persons, who might foreseeably use, repair, or perform maintenance on the cart, must read and understand every instruction before using the device. Cart operators should have access to the manual at all times and should review the directions before each use. Contact Vestil for answers to any question you have after reading the entire manual.**

Although Vestil strives to identify foreseeable hazardous situations that could arise, this manual cannot address every conceivable danger. The end-user is ultimately responsible for exercising sound judgment at all times.

SAFETY GUIDELINES

Failure to read and understand this owner’s manual before using or servicing the cart constitutes misuse of the product.

Read the entire manual before you use the cart for the first time and before each subsequent use. Use the manual to refresh your understanding of the safe use and maintenance procedures that appear on p. 10-13. If questions remain after you finish reading the manual, contact Vestil for answers. DO NOT attempt to resolve any problems with the cart unless you are *certain* that it will be safe to use afterwards.



Electrocution Risk: DO NOT contact live electrical wires with the cart or the load!



Safe operation is the responsibility of the operator! To minimize the possibility of serious bodily injury:

- DO NOT attempt to service a loaded cart. Unload the cart and install maintenance props according to the directions on p. 13 BEFORE working on the cart. DO NOT work under the lift without using the maintenance devices.
- DO NOT attempt to lift or transport loads that exceed the capacity of the cart.
- DO NOT stand, sit or ride on the cart.
- DO NOT put hands or feet under the deck at any time UNLESS the maintenance props are in place.
- Stand clear of the cart while the lift table is moving.
- Keep clear of pinch points! As the deck rises and lowers, pinch points occur between the leg weldments (see Fig. 1, p. 5). NEVER put any part of your body into the scissors mechanism.
- DO NOT use the scissors lift cart UNLESS all safety labels stay in place and legible.
- DO NOT use the cart if you hear unusual sounds while raising or lowering the deck.
- Always watch the platform and the load carefully while raising or lowering the deck.
- ONLY use the cart on compacted, improved surfaces.
- DO NOT leave a loaded cart unattended. ALWAYS unload the cart, and return it to the designated storage location BEFORE you leave the cart unattended.
- DO NOT expose the cart or the charger to rain or adverse conditions.
- **DO NOT modify the cart without the express, written approval from Vestil. Failure to receive authorization for changes to the equipment could render the cart unsafe to use and automatically voids the warranty.**

FIG. 1: Labeled Photograph

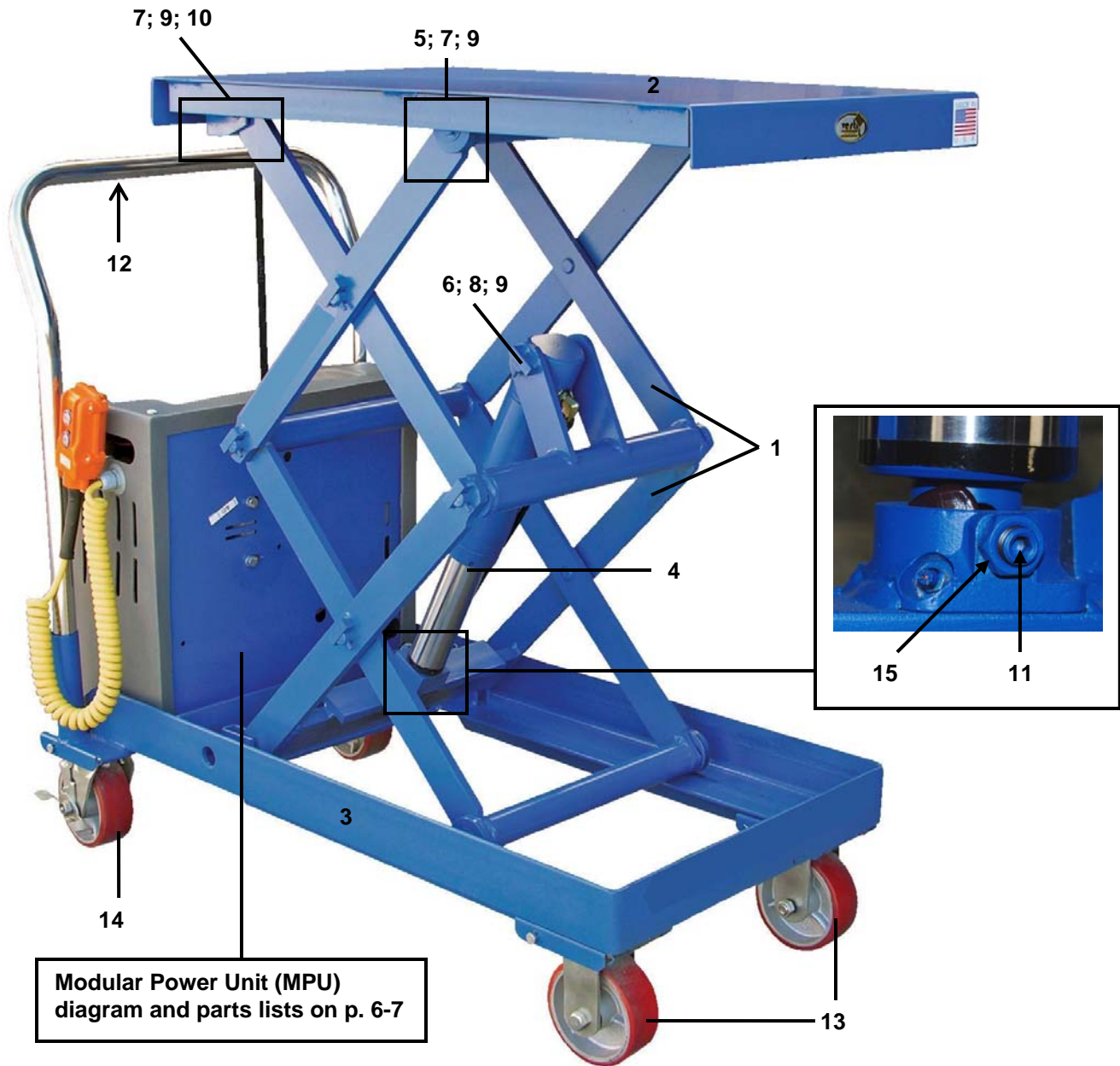

Item No.	Part No.	Description	Quantity
1	01-210-005	Leg weldment assembly	8
2	01-513-008	Deck weldment	1
3	01-514-096	Frame weldment	1
4	01-021-009	Hydraulic cylinder: 2 in. diameter, 7 in. displacement	1
5	01-527-002	Scissor leg roller: 2¼ in. outer diameter, ¾ in. inner diameter, ½ in. thick	4
6	01-112-010	Cylinder pivot pin, ¾ in.	1
7	01-117-002	Retaining snap ring	16
8	01-130-002	Spring pin: 3/16in. diameter, 1-1/8 in. length	1
9	01-113-001	Machine bushing spacer	16
10	01-112-009	Hinge pivot pin	4
11	01-118-002	Cylinder retaining bolt	1
12	99-025-014	Handle: 22 in. wide	1
13	16-132-022	Rigid caster, PS-5/2-RB-R	2
14	16-132-053	Swivel caster, PS-5/2-RB-S-SB	2
15	N/A	½in. - 13 UNC Jam nut	1

Contact Vestil to order replacement or spare parts (see cover page).

To facilitate effective communication, please be prepared to provide the serial number. The serial no. is written on the machine data label.

Vestil is not responsible for problems with or damage to the cart that occur after installation of unapproved replacement parts.

FIG. 2A: DC Modular Power Unit (MPU) Electrical Components

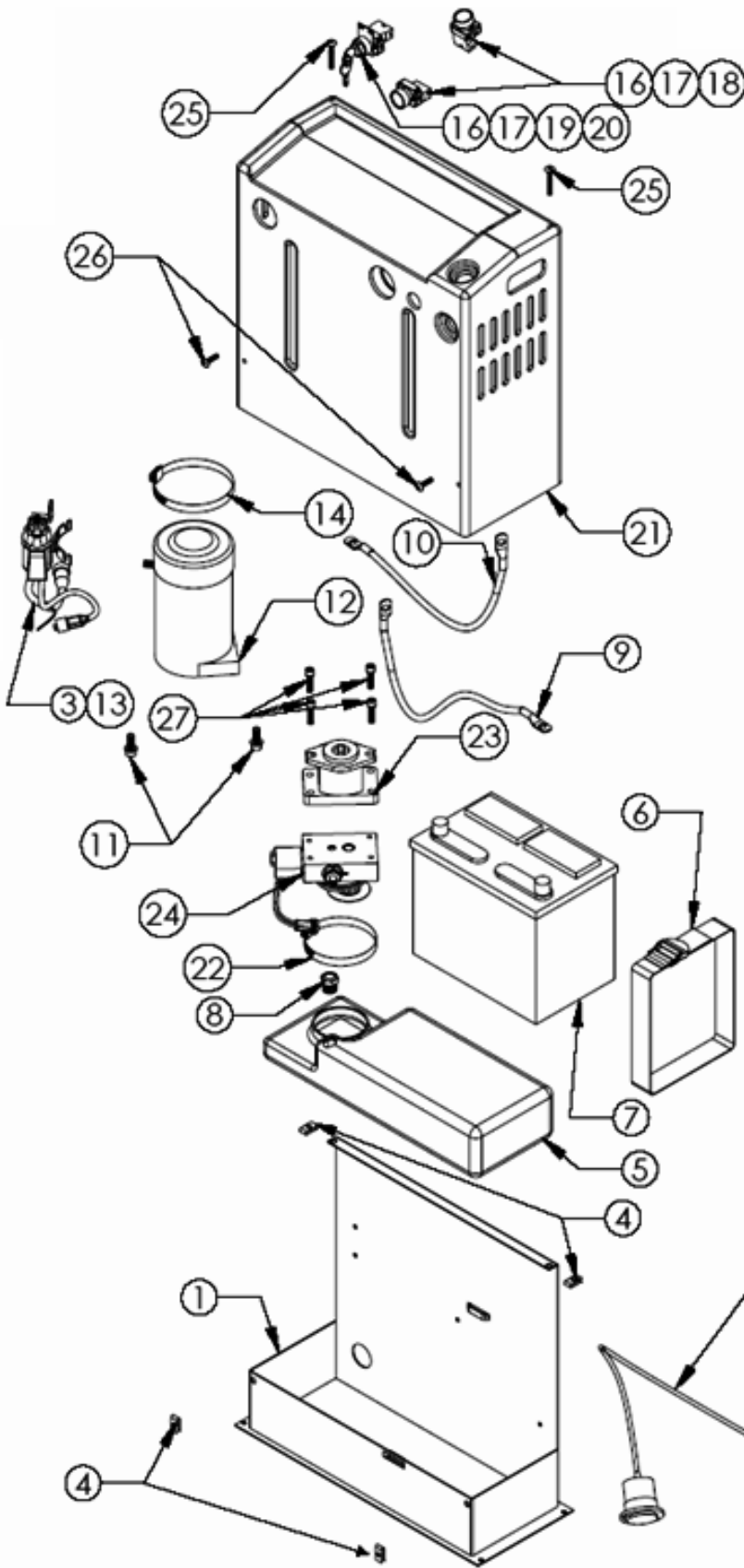

ITEM	REQ	PART NO.	DESCRIPTION
1	1	4JY1119	BASE
2	1	1212SR	BATTERY CHARGER
3	1	01-033-024	18/3 WM4 PIN PLUG
4	4	37927	TINNERMAN CLIP
5	1	99-023-001	RESERVOIR
6	1	99-034-013	BATTERY STRAP
7	1	24DC36	BATTERY
8	1	BV-48	BREATHER
9	1	15-533-013	CABLE, BATTERY 23" BLACK
10	1	15-533-014	CABLE, BATTERY 23" RED
11	2	23305	SHCS UTILITY GRADE
	2	33688	HIGH COLLAR LOCK WASHER
	2	33008	USS FLAT WASHER Z PLATED
12	1	99-135-011	MOTOR, 12VDC
13	1	15-022-004	RELAY, START SOLENOID
14	1	HS64	CLAMP, WORM GEAR
15	1	BG-12V	GAUGE, BATTERY INDICATOR
16	3	ZB2BZ009	BASE, CONTACT BLOCK
17	3	ZB2BE101	CONTACT BLOCK N.O.
18	2	ZB2BA2C	OPERTOR, BLACK, NON-ILLUM.
19	1		KEY SWITCH, 2 POSITION
20	1	01-134-007	LEGEND, ON - OFF
21	1	091802JY	FIBERGLASS COVER
22	1	HS52	CLAMP, WORM GEAR
23	1	01-143-906	PUMP
24	1	01-627-010	MANIFOLD ASSM (SEE PAGE 2)
25	2	29201	TPHMS, Z PLATED
26	2	29185	TPHMS, Z PLATED
27	4	23255	SHCS UTILITY GRADE
	4	33687	HIGH COLLAR LOCK WASHER
28	1	152400-03	MOLDED CORD
29	1	150CCTM.OEM	CONNECTOR, CHARGE
30	10"	3MT ST3540	1"HOOK&LOOPPRESS SENSITIVE

FIG. 2B: DC Modular Power Unit Hydraulic Components

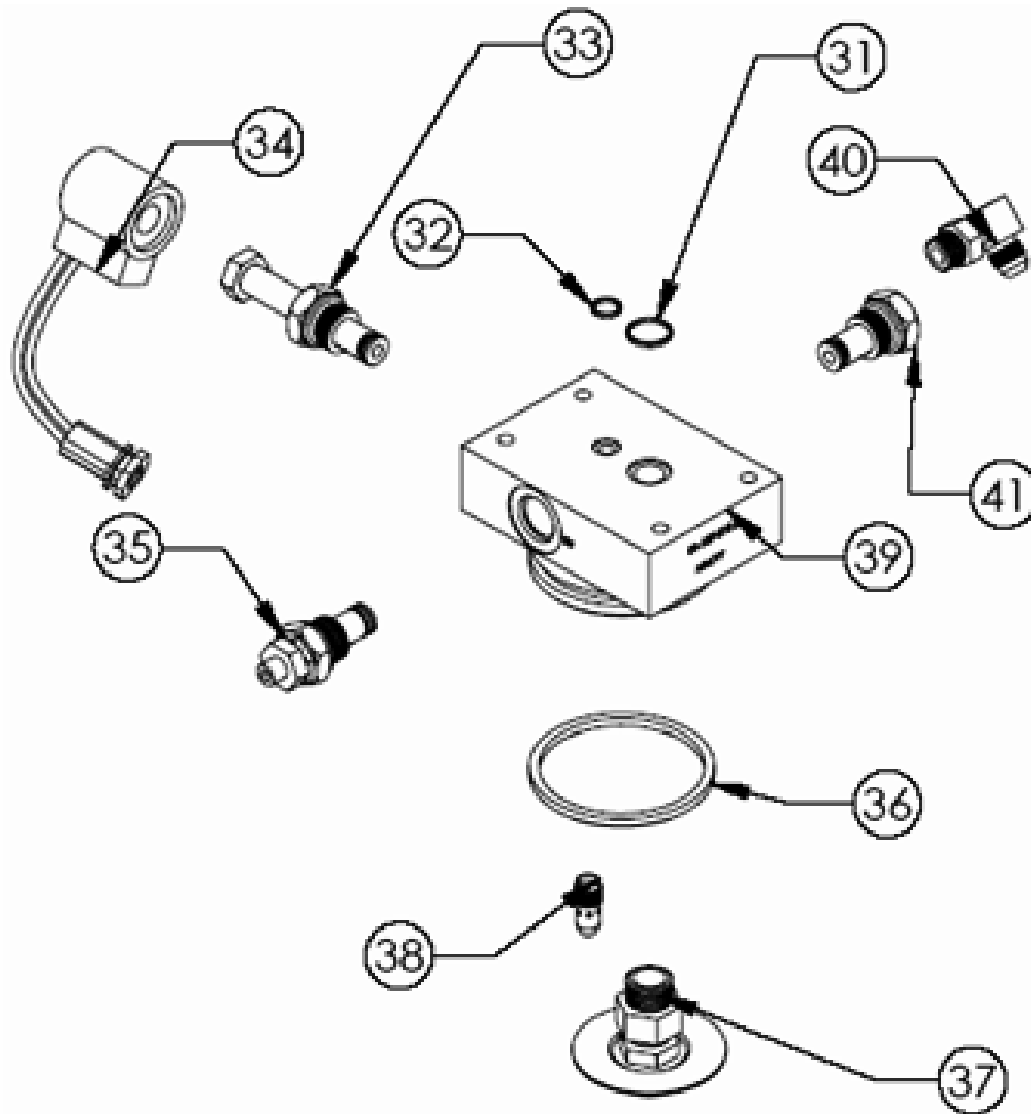

ITEM	REQ	PART NO.	DESCRIPTION
31	1	568-015-BN70	O-RING
32	1	568-011-BN70	O-RING
33	1	99-153-015	VALVE,CARTRIDGE,NC
34	1	99-034-010	COIL, WEATHER TITE PLUG
35	1	99-153-006	VALVE, PRESSURE RELIEF
36	1	568-334-BN70	O-RING
37	1	99-531-005	FILTER
38	1	99-153-038	FLOW CONTROL, 1.0 GPM
39	1	01-127-010	MANIFOLD
40	1	6801-06-06-NOW	MJ-MAORB 90 DEG.
41	1	99-153-011	VALVE, CHECK

FIG. 3: ELECTRICAL DIAGRAM -- MODULAR POWER UNIT

⚠ WARNING To reduce the possibility of injury, BEFORE working on the electrical system:

1. Fully lower and secure the deck;
2. Remove all system pressure and power sources;
3. DO NOT work on the electrical components UNLESS you are trained and authorized to do so.

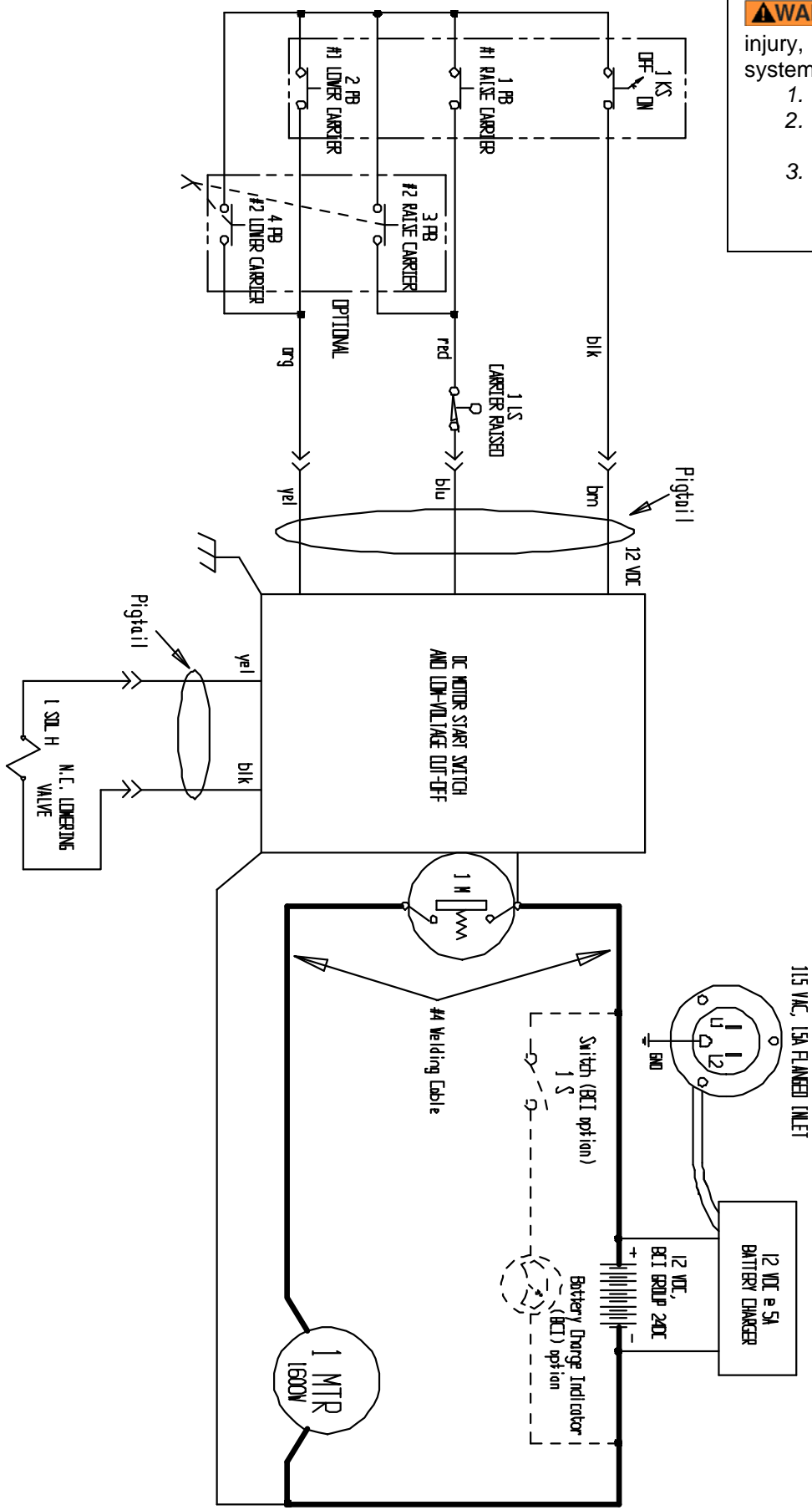
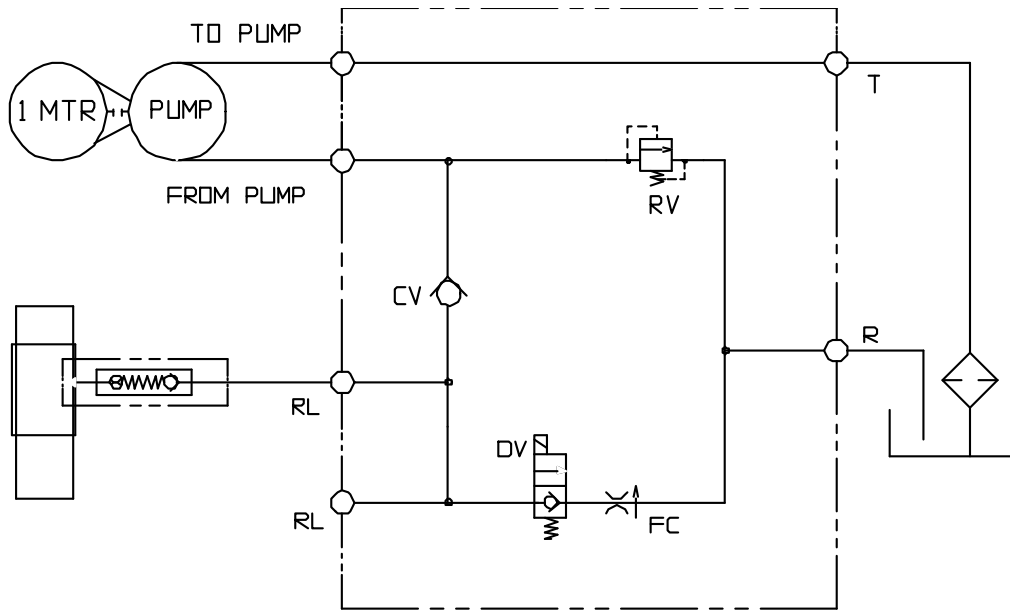

FIG. 4: HYDRAULIC DIAGRAM – LIFT-HOLD-LOWER CIRCUITS



WARNING To reduce the possibility of injury, BEFORE working on the hydraulic system:

1. Fully lower and secure the deck;
2. Remove system pressure and disconnect all power sources;
3. DO NOT work on the hydraulic components UNLESS you are trained and authorized to do so.

GEAR PUMP HYDRAULIC LOGIC DIAGRAM

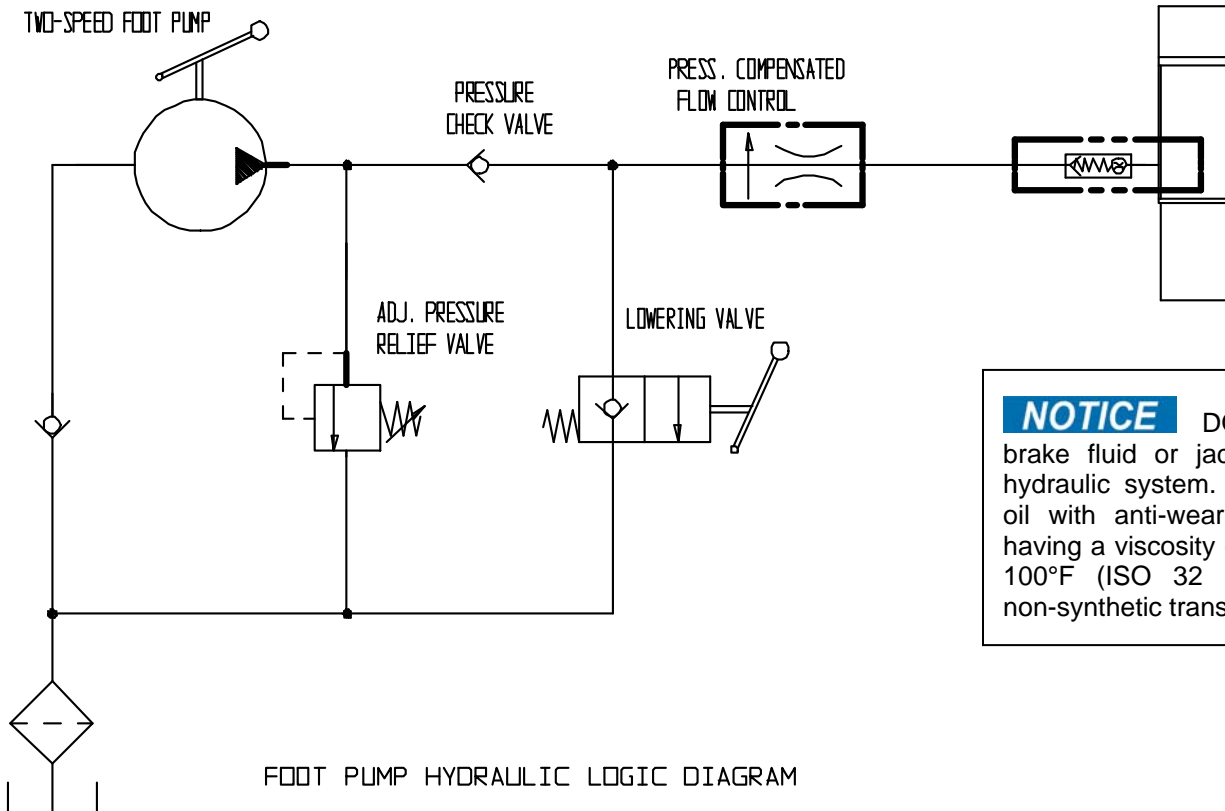

NOTICE DO NOT use brake fluid or jack oils in the hydraulic system. Replace the oil with anti-wear hydraulic oil having a viscosity of 150 SUS at 100°F (ISO 32 @ 40°C), or non-synthetic transmission fluid.

FOOT PUMP HYDRAULIC LOGIC DIAGRAM

USE INSTRUCTIONS:

The cart is suitable for use in most industrial and commercial settings. Only *authorized persons* should use the scissors lift cart. "Authorized person" means someone the end-user approves or assigns to use the cart because he/she is either:

1. **Qualified:** Someone with demonstrated ability to deal with problems relating to the scissors lift cart by virtue of having a recognized degree, certificate, or professional standing, and who additionally has knowledge of, training related to, and experience with scissor lifts carts; AND/OR
2. **Trained:** Someone trained by a qualified person and who has demonstrated the ability to perform particular function(s) on or around a scissor lift.

Use the cart **ONLY** to transport and lift stable, evenly distributed, non-hazardous loads and containers with rigid sides.

LOADING:

The load should be approximately the same size as the deck or smaller. Center and evenly distribute a load on the deck. Position the center of the load at approximately the center of the deck as shown in figures 5A & 5B below.

⚠ WARNING If the cart is improperly loaded, the operator and/or bystanders might be seriously injured:

1. The rated load (in pounds) of the cart appears on the product data label, which is affixed to the left corner of the operator end of the deck. The rated load indicates the **net capacity** of the cart, i.e. the weight of all accessory equipment added to the cart must be added to the weight of the load. The total weight must be less than or equal to the rated capacity of the cart.
2. Always properly stabilize the cart and the load:
 - a. If the load might roll or slide off of the deck, immobilize the load and secure it to the deck before moving the cart. For example, round material like pipe might roll off of the deck. Immobilize the pipe with chocks and use one or more straps to secure the pipe and chocks in place on the deck.
 - b. The deck does not connect to the scissor leg rollers (see FIG. 3A below), and therefore, the deck may pivot off of the rollers. The pivot point is represented in FIG. 3A as an "X". To prevent the deck from tipping up towards the operator, avoid end-loading the deck, i.e. centering loads on the portions of the deck highlighted in FIG. 5A, "DO NOT center load on this part of deck". For applications involving side or end edge loading, consult the factory.

FIG. 5A: Proper Load Positioning (Side View)

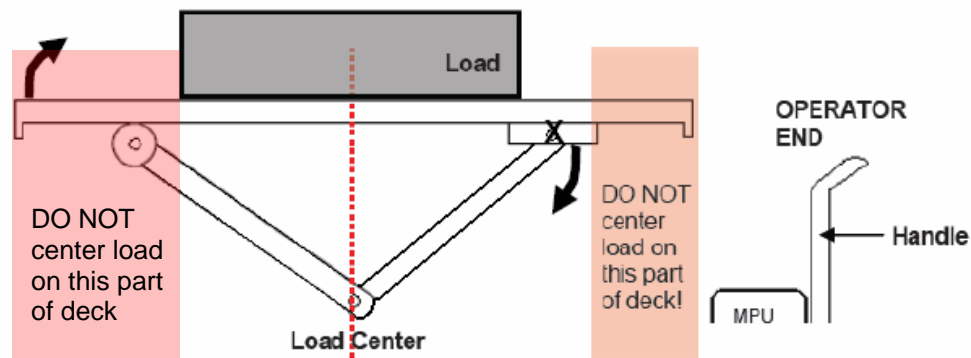
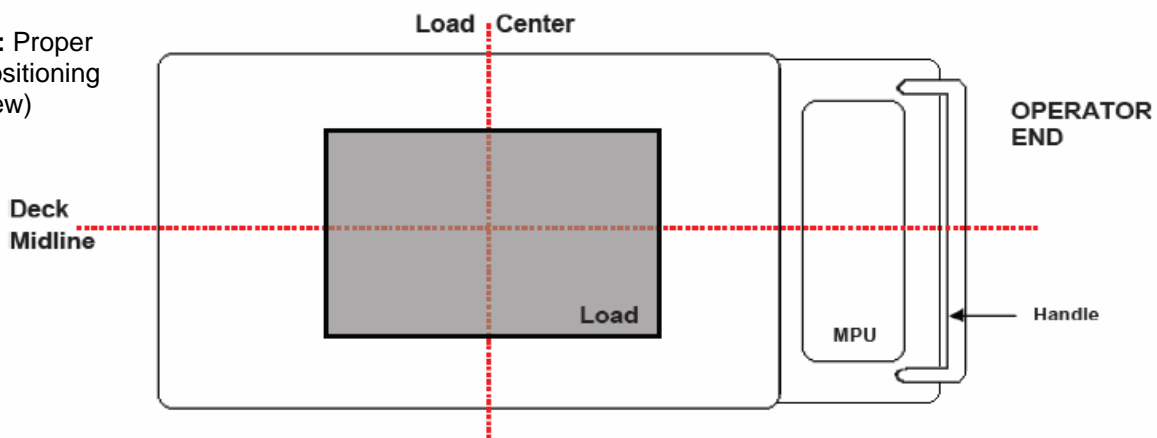

FIG. 5B: Proper Load Positioning (Top View)



LIFT TABLE OPERATION :

⚠WARNING Instruct other persons in the area to stand at a safe distance while the deck raises or lowers. Be certain no part of any person, clothing, or object is under any part of the platform before lowering the deck.

The Modular Power Unit (MPU) controls the scissors lift table portion of the cart by means of a constant pressure (dead-man style) pushbutton controller.

- To raise the deck, press the “UP” button. The button activates the motor and the deck will rise. However, the deck will rise only *as long as the control is pressed*. When the button is released, the deck will stop moving and will maintain its elevated position.
- To lower the deck, press and hold the “DOWN” button. In response, the lowering valve energizes and gravity causes the deck to descend. The motor does not run during descent. When the button is released, the deck stops descending and holds its current position.

⚠WARNING DO NOT use the cart if:

1. You notice any damage or hear unusual noise(s) while raising or lowering the deck;
2. The cart requires maintenance or repairs; or
3. The cart malfunctions in any way.

Tag the cart “Out of Service” and immediately notify your supervisor or maintenance personnel if you notice anything out of the ordinary.

The motor relay protection feature activates when the battery charge is low; it prevents the motor from running and thus the deck cannot be raised. Adequate battery voltage is indicated by a green LED on the motor relay. If the deck does not rise when you press the UP button, recharge the battery according to the instructions given in the section titled, “Battery Charger Operation”.

The cart is manually propelled. The MPU only powers the scissors lift table; it does not propel the cart. After loading the cart and properly securing the load to the deck, push the cart to the desired location. Do not exceed a rate of two feet per second when transporting a load with the cart.

BATTERY CHARGER OPERATION:

⚠WARNING Working with or near lead acid batteries is dangerous. ONLY work on or replace the battery if authorized and trained to do so.

- Batteries contain sulfuric acid and produce explosive gases. A battery explosion could result in loss of eyesight or serious burns. ALWAYS wear eye and face protection as well as personal protective clothing as required by OSHA regulations (29 CFR.1910 Subpart I and 29 CFR.1926.441) whenever you work on or with the battery.
- DO NOT smoke in the vicinity of the battery, and do not expose the battery to sparks or flames. ONLY charge the battery in locations that are clean, dry, and well ventilated.
- DO NOT operate the charger if either charger cable is coiled. Charging the battery while the cord is either coiled or wrapped around itself could cause a short circuit or fire, and the cord might overheat and/or melt.
- DO NOT lay tools or anything metallic on top of the battery.
- To reduce the possibility of being severely burned, remove personal items like rings, bracelets, necklaces, and watches. Batteries produce enough energy to weld jewelry to metal.
- ALWAYS have fresh water and soap nearby in case battery acid contacts skin, clothing, or eyes.
- Replace defective cords or wires immediately.
- Frequently check the water level of the battery.

Fully uncoil both of the charger cables.

Connect the charger cables to the battery in the following order:

1. The ribbed wire (of the charger output cord) connects to the negative (-) terminal on the battery.
2. The plain wire (with text printed on it) connects to the positive (+) terminal on the battery.

Plug the charger into a standard 115V receptacle. If an extension cord is necessary, use the shortest, thickest cord available.

When properly connected, LED’s on the charger indicate the status of battery recharging:

- Flashing green LED – the charger detects a poor connection to the battery.
- Solid yellow LED – the charger is charging the battery.
- Solid green LED – the battery is fully charged. The charger can remain connected to the battery indefinitely without harming the battery

NOTICE Remember to unplug the charger before moving the equipment to prevent damaging the cords, receptacles, and other equipment.
Operating the battery with a low battery voltage might cause premature motor contact failure.

HYDRAULIC SYSTEM OPERATION:

An electric motor directly coupled to a gear-type hydraulic pump produces the fluid pressure and flow the cylinder requires to raise the deck and a load. A hydraulic manifold bolted directly onto the gear pump houses the hydraulic control components. The hydraulic components are all rated for 3,000 psi working pressure.

Key components and specifications of the power unit include:

- Electric motor: powered with a 12 VDC battery.
- Gear pump: shaft coupled directly to the shaft of the electric motor.
- Check valve: prevents backflow of fluid through the pump. It allows the deck to hold a given elevation indefinitely.
- Pressure relief valve: opens a path for fluid to follow back to the reservoir if the fluid pressure exceeds 3,000 psi.
- Lowering solenoid valve: an electrically-operated cartridge valve that includes a screen to keep contaminants out of the valve.
- Pressure-compensated flow control spool: located under the lowering valve; it regulates fluid flow back to the reservoir when the valve opens. It allows the deck to lower at a consistent rate when loaded and unloaded.
- Hydraulic lift cylinder: single action.
- Safety velocity fuse: installed in the hose port of the cylinder. It closes automatically if a catastrophic hose failure occurs, which prevents the lift table from collapsing. Once activated, the deck remains stationary until pressure is reapplied to the system.
- Hydraulic fluid: uses HO150 hydraulic fluid. Any anti-wear hydraulic fluid with an SUS viscosity of 150 - 200 at 100°F (SAE viscosity grade of 32) such as AW-32 or Dexron transmission fluid is acceptable.

To raise the deck, press the “UP” pushbutton. The motor turns and spins the hydraulic gear pump. Oil is drawn from the reservoir through the suction filter and into the pump. The pump pushes pressurized oil through the check valve and out to the lift cylinders.

To lower the deck, press the “DOWN” pushbutton. The lowering valve opens, which bypasses the check valve, and the oil in the cylinder returns to the reservoir through the return hose. The deck lowering rate is regulated by an internal pressure-compensated flow spool.

If the deck continues to slowly lose elevation even after you release the “DOWN” button, remove the lowering cartridge valve for inspection and cleaning:

- Remove any load from the platform.
- Raise the lift and then lower the maintenance props. Guide the props into the cylinder push assembly as you lower the platform. Hold the DOWN pushbutton until the lift rests on the props.
- Remove the nut that fastens the solenoid coil to the valve stem; then remove the coil. Unscrew the valve from the manifold.
- Inspect the valve for contaminants.
- Inspect the o-rings and back-up washers of the valve for cuts, tears, or other damage.
- Immerse the valve in mineral spirits or kerosene; use a thin tool like a small screwdriver or hex wrench to push the poppet in and out several times from the bottom end of the valve. The valve should move freely by approximately 1/16” between the closed and open positions. If it sticks in, the valve stem might be bent and should be replaced if it doesn’t free up after cleaning. Remove mineral oil from the valve with compressed air; move the poppet in and out at the same time.
- Inspect the bottom of the valve cavity in the manifold for contaminants.
- Press on the middle of the flow control spool with a thin tool. The flow control spool is located in the bottom of the valve cavity. The spool should move freely.
- Reinstall the valve into the manifold and tighten the valve with approximately 20 lb-ft of torque.

If the deck lowers either *extremely* slowly or not at all, the culprit might be air in the hydraulic cylinders, which could cause the velocity fuse in the cylinder to close. To correct the problem, bleed the air from the system:

- Unload the cart.
- Fully raise the deck and then install the maintenance props. Hold the DOWN pushbutton until the rollers firmly contact the props.

- Pull the bottom of the cylinder out of the push assembly and raise the end up higher than any other part of the hydraulic system. Rotate the cylinder so the hose port is pointing up.
- Loosen the hose fitting by a ½ turn; then “jog” the motor. Oil and air will sputter from the loose fitting. Once the air is gone, tighten the fitting and replace the cylinder into the push assembly.

MAINTENANCE AND INSPECTIONS:

Only trained and authorized persons should maintain, repair, adjust and inspect the scissor lift cart. Maintenance and Inspection personnel should verify that the cart complies with all regulations, codes, and standards that apply to Industrial Scissors Lifts in the location where the cart is *used*. The person(s) designated to conduct inspections **by your employer** must inspect the cart before it is used for the first time and prior to EACH use thereafter.

Maintenance Props: Use two pieces of 4in. x 4in. timber (or some other compression resistant material like, for example, 1.5in x 1.5in. square bar) of sufficient length to allow you to access the underside of the deck. Fully raise the deck; then insert the props between each roller and the front of the frame. Arrows in the photograph to the right indicate where the props should be placed. Press the DOWN button to lower the deck; release the button when the rollers firmly contact the props and the deck stops descending.

To remove the props after work is finished, fully raise the deck, and then remove the props.

(A) Inspect daily for:

- 1.) Frayed wires;
- 2.) Oil leaks from the hydraulic system;
- 3.) Pinched or chafed hydraulic lines;
- 4.) Damage to or structural deformation of:
 - scissor leg weldments, pins, rollers, leg brackets (that connect legs to deck or frame), and all fastening hardware;
 - cylinder or cylinder retention brackets;
 - frame weldment;
 - castors;
- 5.) Unusual noise or binding, or evidence thereof;
- 6.) Labels affixed to the cart.

(B) Inspect monthly for:

- 1.) Oil level (oil should be 1” to 1½” below the fill hole in the reservoir with the deck fully lowered);
- 2.) Oil leaks;
- 3.) Worn or damaged electrical wires or hydraulic hoses;
- 4.) Pivot point wear;
- 5.) Roller looseness and wear;
- 6.) Integrity of the retaining hardware on all rollers and on all pivot point pins.
- 7.) Looseness, wear, or damage to the casters’ bearings, mounting hardware, or surface material.
- 8.) Proper water level in the battery (DC units only.)
- 9.) Unusual noises.
- 10.) All the information, safety, and warning labels being in place and in good condition.
- 11.) The need to clean off dirt and debris.

(C) Yearly inspection:

Change the oil if it darkens, becomes gritty, or turns a milky color (indicating the presence of water). Replace the contaminated oil with anti-wear hydraulic oil having a viscosity grade of 150 SUS at 100°F (ISO 32 at 40°C) such as AW 32 or HO 150 hydraulic oil, or a non-synthetic transmission fluid. You may use a synthetic transmission fluid if you flush the system with the synthetic fluid before filling the reservoir.

⚠WARNING Before inspecting, performing maintenance on or repairing the cart, unload the cart, raise the platform, and install maintenance props on both sides.

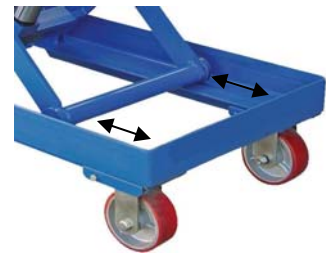

⚠WARNING DO NOT use a cart that is structurally damaged in any way. Structural damage includes, but is not limited to, bending, warping, cracking or other deformation of one or more of the scissor leg weldments, the frame, rollers, or the deck (see FIG. 1, p. 5). Restore the cart to normal operating condition **BEFORE** using it again.

NOTICE DO NOT use brake fluid or jack oils in the hydraulic system. If oil is needed, use an anti-wear hydraulic oil with a viscosity grade of 150 SUS at 100°F, (ISO 32 cSt @ 40°C), or Dexron transmission fluid.

TROUBLESHOOTING:

If the unit does not operate, check all of the electrical connections. In particular, examine the connections at the battery, the motor, and all points at which a wire connects to the chassis. Also check the quick-connect plug at the end of the pendant control cord. If the connection is loose, push the plug into the socket.

At room temperature, a fully charged lead acid battery in nominal condition should hold 12.65 volts of electrical energy. The battery is fully discharged when the voltage drops to 11.9 volts. Do NOT check the voltage unless the charger has been turned off for at least 1/2 hour.

If the batteries don't recharge, check the 115V supply circuit in the charger. Also measure the output from the charger with a voltmeter. If the charger is in normal operating condition, determine the battery's state of charge with a hydrometer or a voltmeter.

<u>Problem:</u>	<u>Possible cause(s):</u>	<u>Action:</u>
Power unit doesn't run when "UP" button is pressed.	Upper-travel limit switch is engaged or bad. Bad motor relay coil. Battery voltage low.	Test with meter; replace if bad.
Motor runs but deck doesn't move. Motor hums or pump squeals, but either: 1. the deck does not move; or 2. the platform moves very slowly.	Control cable connector is loose. Pump not functional. Platform overloaded. Pressure relief opening at full pressure.	Test with meter; replace if bad. If LED on motor relay is not on, check battery voltage with meter. Check quick-connect plug. Contact factory. Verify that the load doesn't exceed the table's capacity. Check for structural damage or binding of the scissor legs, etc. Check for platform overload condition.
Spongy or jerky deck movement.	Excessive air in the hydraulic cylinders.	Bleed air per procedure described in this manual.
Deck won't lower.	Solenoid coil is bad or connector is loose. Solenoid valve or suction hose screen plugged. Physical blockage of the structure.	Check with meter. Check quick-connect plug. Remove and inspect. Clean per instructions in this manual. Inspect for foreign material or objects that might block the leg set or its rollers.
Platform lowers too slowly.	Pinched hose. Flow control spool sticking.	Check pressure, supply, and return hoses for kinks. Remove plug from FC port; push on flow spool to ensure it is fully pressed into the cavity.
Platform rises but slowly loses elevation (drifts down).	Velocity fuse locking (platform only slowly creeps down). Contamination holding open the lowering valve or the check valve.	Same as for jerky deck movement. Remove and inspect. Clean per instructions in this manual.

MARKINGS:

Only use the lifter if ALL labels are readable and undamaged. Contact Vestil for replacement labels if necessary, and DO NOT use the lifter until all replacement labels are affixed to the device.

FIG. 6: Label placement



Label #207:

⚠ WARNING	TO AVOID PERSONAL INJURY READ OWNER'S MANUAL BEFORE OPERATING OR REPAIRING SCISSOR LIFT.		DO NOT WORK UNDER LIFT WITHOUT SAFETY BECK OR WHILE LOADED. KEEP CLEAR OF MOVING SCISSOR/LEG MECHANISM.		DO NOT STAND ON OR RIDE ON LIFT.
⚠ ADVERTENCIA	PREVENIR DAÑOS PERSONALES LEER MANUAL DEL PROPIETARIO ANTES DE OPERAR O REPARAR EL ELEVADOR DE TIERNAS.		NO TRABAJE DEBAJO DEL ELEVADOR SIN LOS FRENSOS DE SEGURIDAD O CUANDO ESTE CARGADO. MANTENGASE ALEJADO DEL MECANISMO DE TIERNAS/MOVIMIENTO.		NO SE SENTE, SEFARE O VIRE EN EL ELEVADOR.
⚠ AVERTISSEMENT	POUR ÉVITER TOUTE BLESSURE PERSONNELLE LIRE LE MANUEL D'UTILISATION AVANT DE METTRE EN MARCHÉ OU AVANT DE RÉPARER L'ÉLEVATEUR CISEAU.		NE PAS TRAVAILER SOUS L'ÉLEVATEUR SANS BLOCQUE DE SÉCURITÉ OU QU'IL SOIT LEST CHARGÉ. RESTER À L'ÉCART DU MÉCANISME CISEAU LORSQUE L'ÉLEVATEUR EST EN FONCTIONNEMENT.		NE PAS SE TENIR DEBOUT, S'ASSEoir OU MONTER SUR L'ÉLEVATEUR.

Label #208:

⚠ WARNING	⚠ ADVERTENCIA	⚠ AVERTISSEMENT
KEEP CLEAR OF PINCH POINT	MANTENGASE ALEJADO DEL PUNTO DE CORTE	SE TENIR À DISTANCE DU POINT DE PINCEMENT
VESTIL MANUFACTURING CORPORATION • Phone (260) 665-7586 • Fax (260) 665-1339 • sales@vestil.com • www.vestil.com		

Label #287:

MODEL/MODELO/MOÛLE _____
CAPACITY _____ lbs.
CAPACIDAD/CAPACITÉ _____ kgs.
SERIAL/SERIE/SÉRIE _____
VESTIL MANUFACTURING CORPORATION
sales@vestil.com • www.vestil.com

Label #206:

ISO 32 / 150 SUS
HYDRAULIC OIL OR NON-SYNTHETIC TRANSMISSION FLUID
ACEITE HIDRAULICO O LIQUIDOS DE TRANSMISION NO SINTETICOS
HUILE OU LIQUIDE HYDRAULIQUE NON-SYNTHÉTIQUE
VESTIL MANUFACTURING CORPORATION • Phone (260) 665-7586 • www.vestil.com

Label #295:

DANGER
CORROSIVE MATERIAL
PELIGRO
MATERIAL CORROSIVO
DANGER
MATIÈRES CORROSIVES
T & S Equipment Company Ph (219) 865-9521 • Fax (219) 865-1339 New area code (260) in 2002

Label #269:

⚠ WARNING	⚠ ADVERTENCIA	⚠ AVERTISSEMENT
INSTALL BOTH MAINTENANCE STOPS before working under this table. DO NOT use maintenance stops with table loaded.	INSTALE AMBOS TOPOS DE MANTENIMIENTO antes de trabajar debajo de esta mesa. NO use los topos de mantenimiento con la mesa cargada.	INSTALLER LES DEUX BUTOIRS D'ENTRETIEN avant de travailler sous cette table. NE PAS utiliser les butoirs d'entretien quand la table est chargée.
VESTIL MANUFACTURING CORPORATION, Angola, IN 46703 USA, Phone (260) 665-7586 • www.vestil.com		